

Stereochemistry and stereocontrolled synthesis (OC 8)

A lecture from Prof. Paul Knochel,
Ludwig-Maximilians-Universität München

WS 2018-19

Wichtig!

- Klausur Stereochemistry
05. Februar 2019
8:00 – 10:00
Willstätter-HS
- Nachholklausur Stereochemistry
9. April 2019
08:00 – 10:00
Wieland-HS

Problem set part I

First Problem Set for OC I Part I Prof. Paul Knochel

1) Geben Sie die Anzahl von Stereoisomeren sowie ihre stereochemische Bezeichnung (Enantiomer, Diastereoisomer) der folgenden Verbindungen:

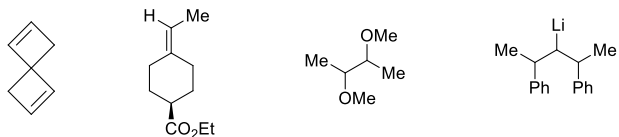

2) Geben Sie das Produkt der folgenden Umsetzungen:

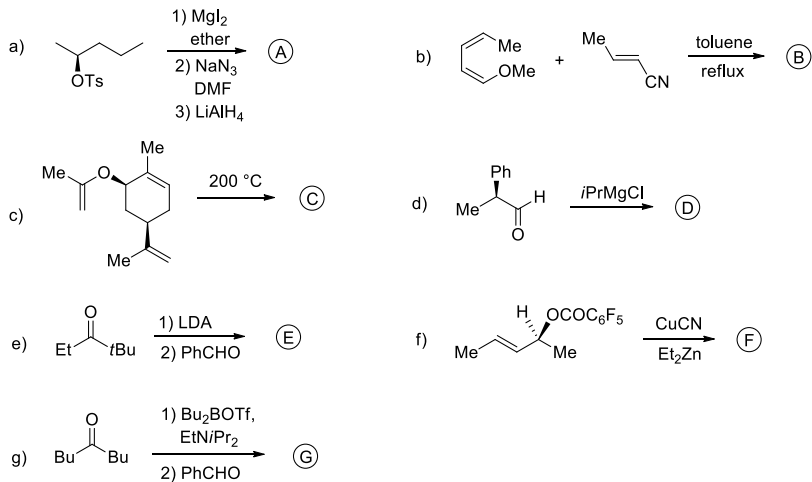

3) Klassifizieren Sie die markierten prochiralen Protonen (homotop, enantiotop, diastereotop) der folgenden Verbindungen:

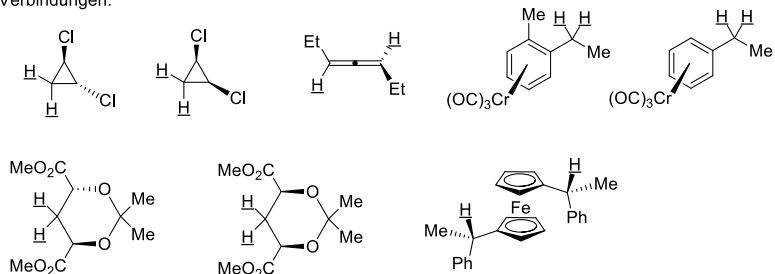

4) Geben Sie die Anzahl und stereochemische Bezeichnung der Mono-Epoxidierungsprodukte folgender Verbindungen:

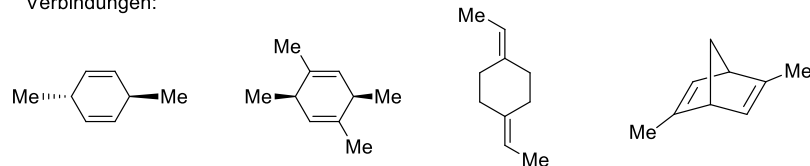

5) Durch Zugabe von $ZnCl_2$ wird das hier vorliegende Molekül epimerisiert, d. h. es entstehen zwei Diastereoisomere. Geben Sie einen möglichen Mechanismus für die Epimerisierung an:

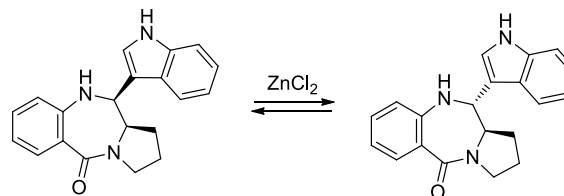

Problem set part II

First Problem Set for OC I part II Prof. Paul Knochel

Stereoselective synthesis of (R,R) or (S,R)-juvabione

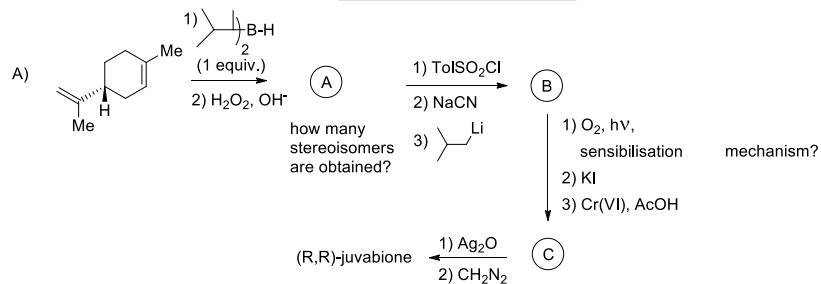
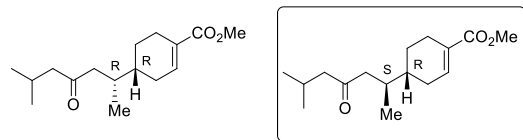

G. Saucy, *J. Am. Chem. Soc.* **1970**, 92, 336

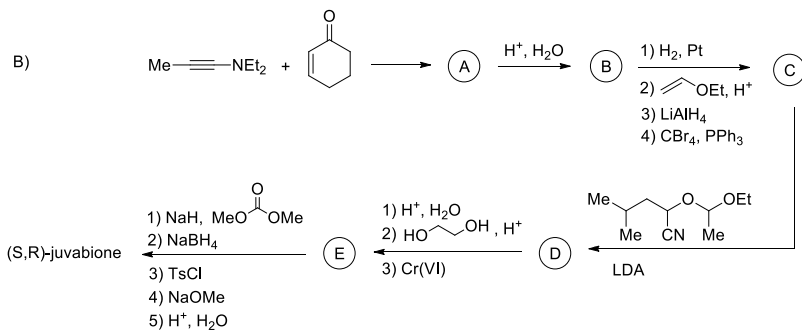

J. Ficini, *J. Am. Chem. Soc.* **1974**, 96, 1213

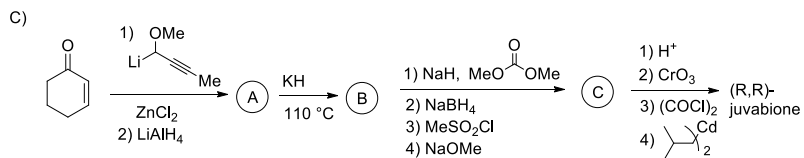

D. A. Evans, *J. Am. Chem. Soc.* **1980**, 102, 774

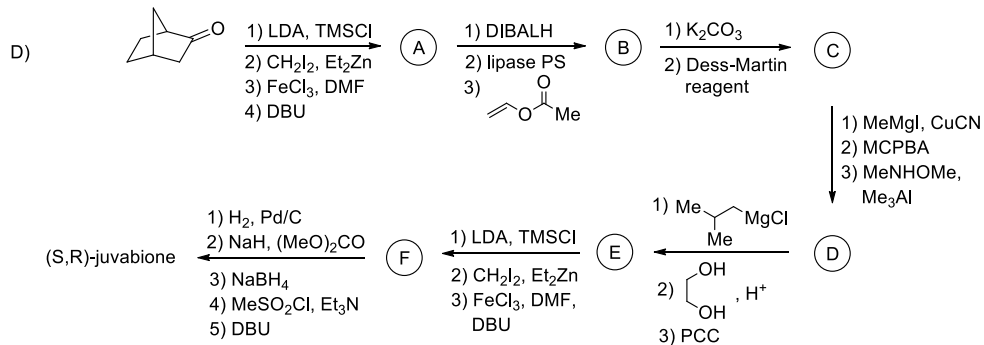

K. Ogasawara, *Tetrahedron Lett.* **1999**, 40, 4207

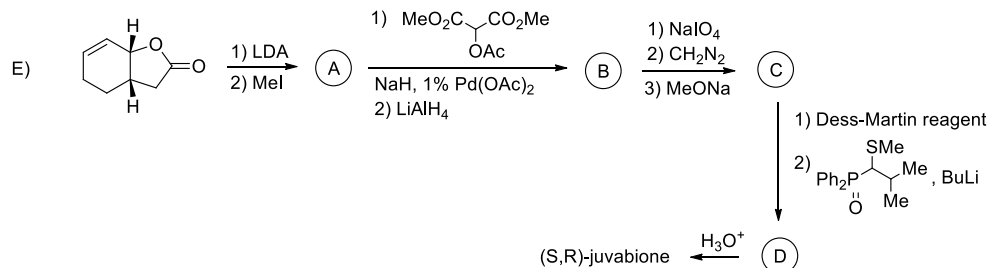

G. Helmchen, *J. Org. Chem.* **2000**, 65, 5072

Problem set part III

First Problem Set for OC I part III Prof. Paul Knochel

1) Geben Sie das Produkt der folgenden Reaktionen:

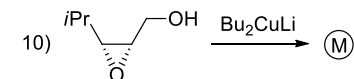
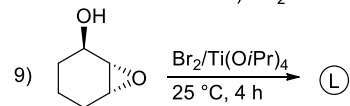
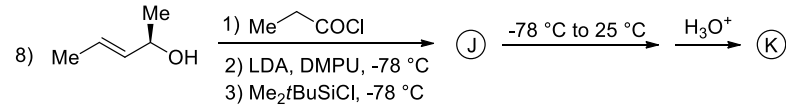
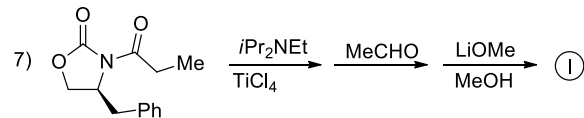
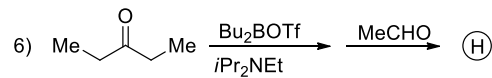
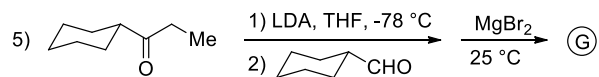
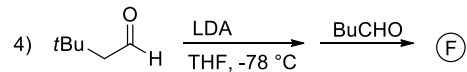
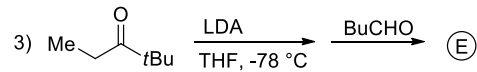
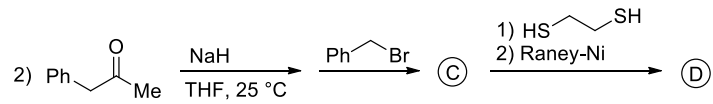
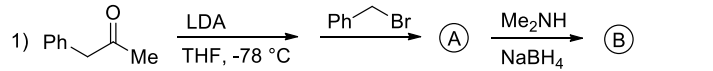

2) Wie können Sie folgende chirale Verbindungen herstellen?

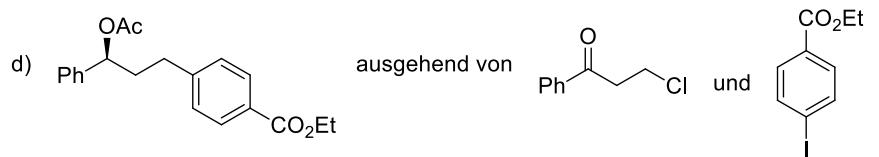
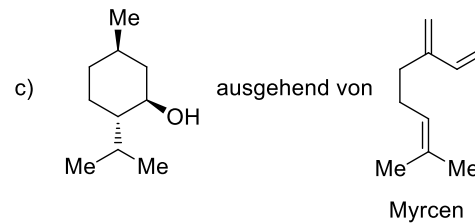
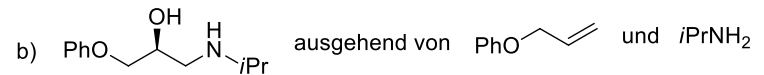
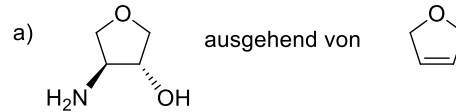

Recommended Literature

- E. Juaristi, Stereochemistry and Conformational Analysis, Wiley, 1991.
- E. Eliel, Stereochemistry of Organic Compounds, Wiley, 1994.
- A. Koskinen, Asymmetric Synthesis of Natural Products, Wiley, 1993.
- R. Noyori, Asymmetric Catalysis, Wiley, 1994.
- F. A. Carey, R. J. Sundberg, Advanced Organic Chemistry, 5th Edition, Springer, 2007.
- A. N. Collins, G. N. Sheldrake, J. Crosby, Chirality in Industrie, Vol. I and II, Wiley, 1995 and 1997.
- G.Q. Lin, Y.-M. Li, A.S.C. Chan, Asymmetric Synthesis, 2001, ISBN 0-471-40027-0.
- P. Deslongchamps, Stereoelectronic Effects in Organic Chemistry, Pergamon, 1983.
- M. Nogradi, Stereoselective Synthesis, VCH, 1995.
- E. Winterfeldt, Stereoselective Synthese, Vieweg, 1988.
- R. Mahrwald (Ed.), Modern Aldol Reactions, Vol. I and II, Wiley, 2004.
- C. Wolf, Dynamic Stereochemistry of Chiral Compounds, RSC Publishing, 2008.
- A. Berkessel, H. Gröger, Asymmetric Organocatalysis, Wiley-VCH, 2005.
- J. Christoffers, A. Baro (Eds.), Quaternary Stereocenters, Wiley-VCH, 2005.
- Catalytic Asymmetric Synthesis, I. Oshima (Ed.), Wiley, 2010.

Stereochemical principles - introduction and definitions

- Isomers are molecules having the same composition
- Structural isomers have different connectivities:

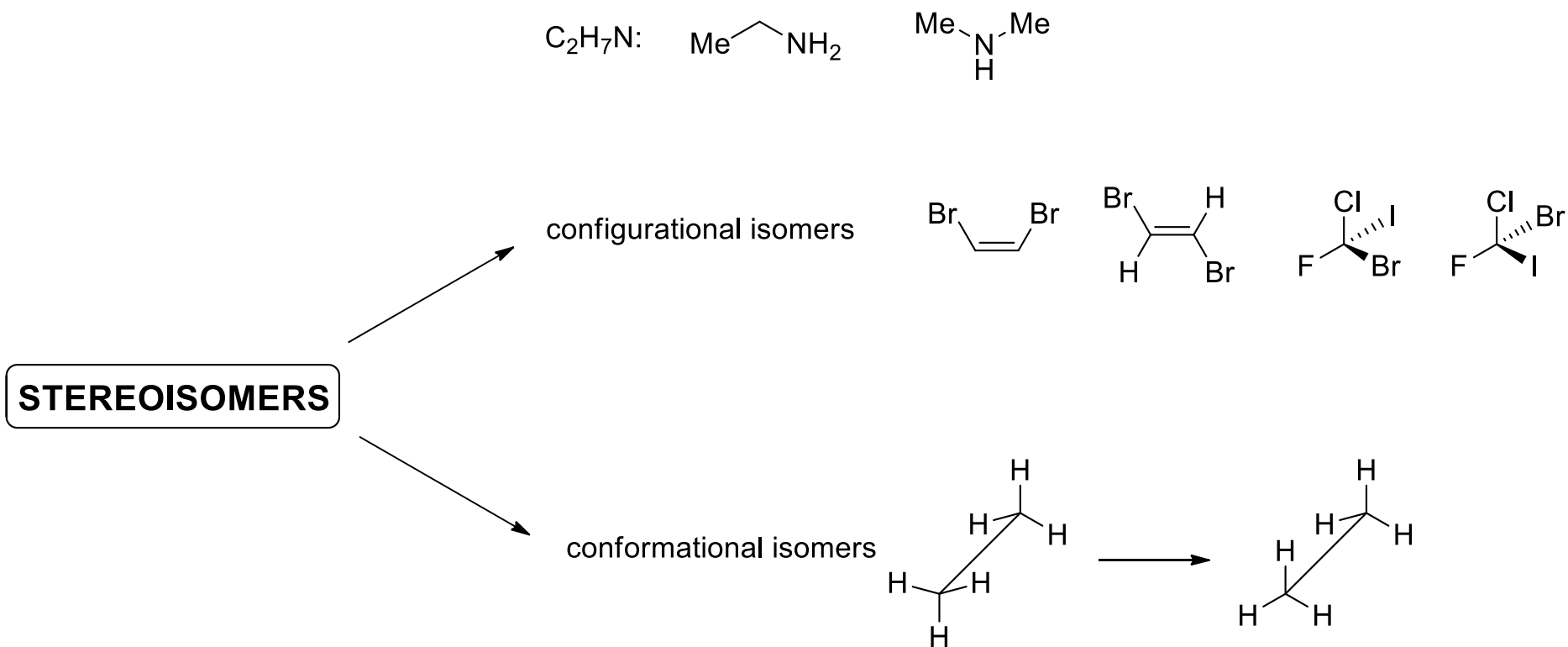

Classification of stereoisomers

Enantiomers are two stereoisomers which are mirror images

Diastereomers are stereoisomers which are not enantiomers

Configuration isomers:



Conformation isomers:

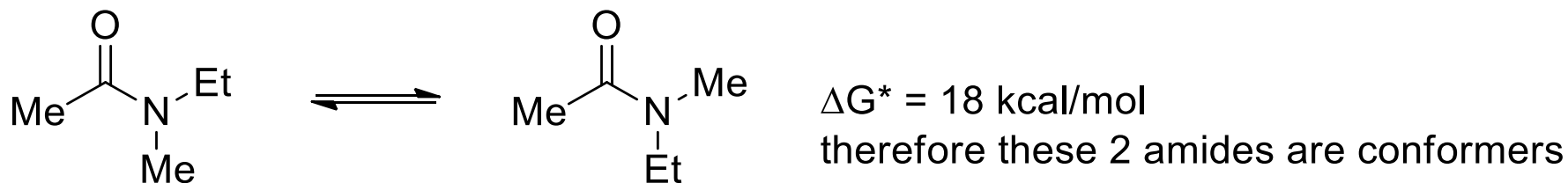

The energy barrier has to be over 25 kcal/mol in order to speak of configurational isomers.

Introduction: classification of stereoisomers

- Conformation isomers:

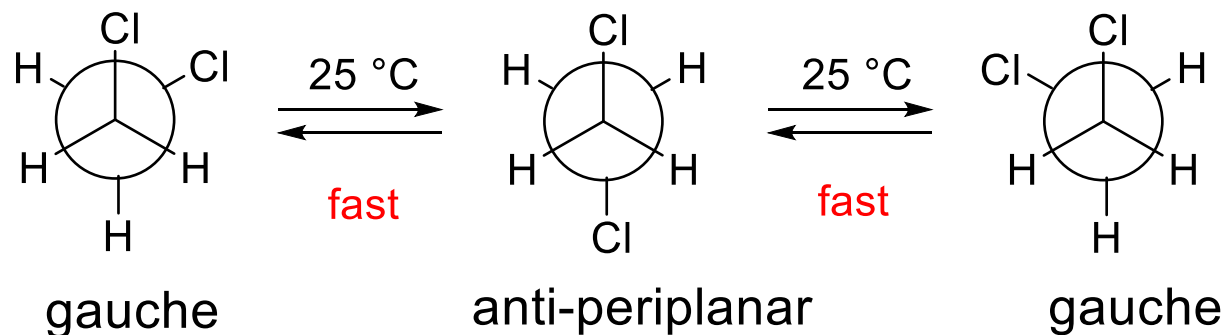

$$\Delta E^* = 3-5 \text{ Kcal/mol}$$

All processes having an energetic barrier (activation energy ΔE^*) lower than 19 Kcal/mol proceed at 25 °C

Introduction: classification of stereoisomers

lactic acid as example

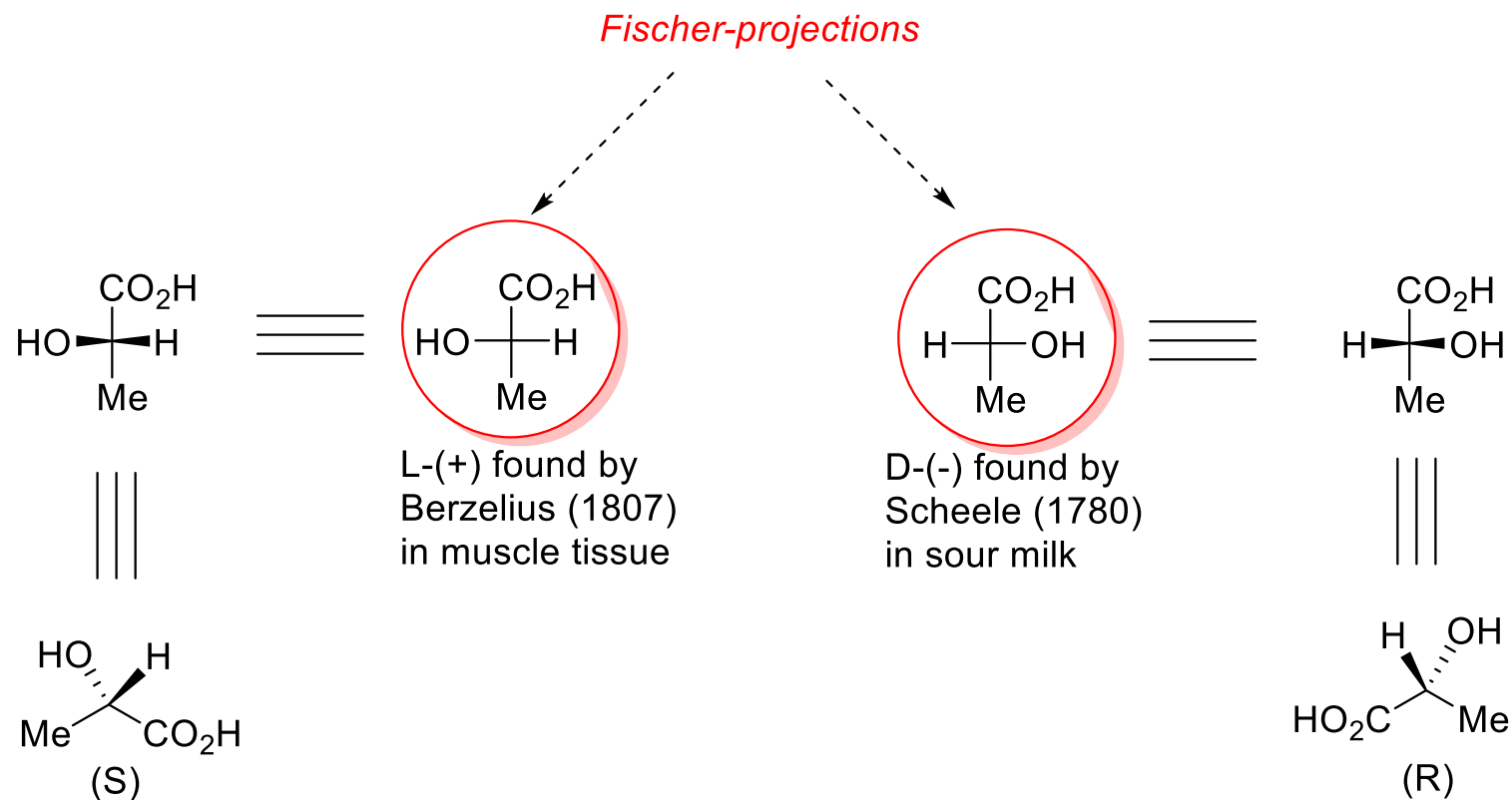

1874 suggestion by Van't Hoff; LeBel

The tetrahedral arrangement of substituents at Csp^3 carbon centers.

Definitions

Chirality: A molecule is chiral if it is not identical with its mirror image.

A chiral carbon-center bears 4 different substituents.

An organic molecule with n chiral centers has 2^n stereoisomers, if no additional symmetry element is present in this molecule.

A molecule is **achiral** if it contains a plane of symmetry or a center of inversion or a S_n symmetry element.

A **chiral** molecule may contain only C_n symmetry element and *identity* (E)

Tartaric acid exists only as 3 different stereoisomers:

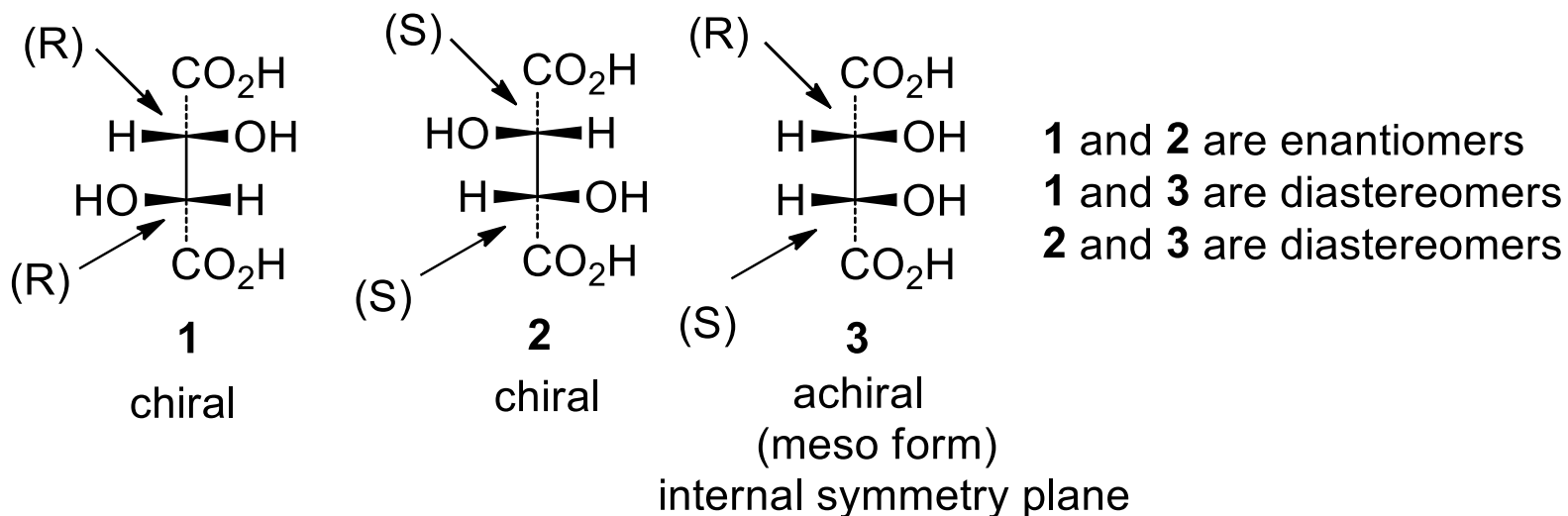

Properties of enantiomers

Two enantiomers have identical physical properties but show the opposite rotation of polarized light in a polarimeter.

Importantly, the biological properties of enantiomers are different!

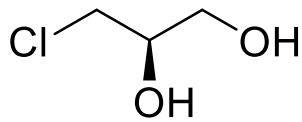

poison

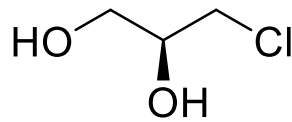

useful pharmaceutical

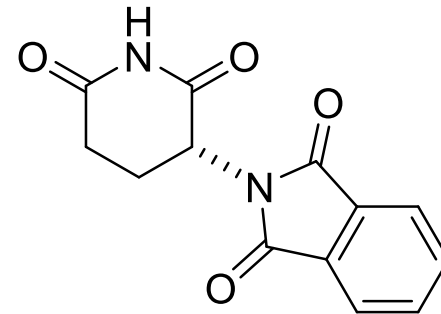

potent hypnotic

the enantiomer is teratogenic!

95% of all drugs are chiral, therefore the enantioselective synthesis of organic molecules is of key importance.

Chiral molecules not centered at carbon

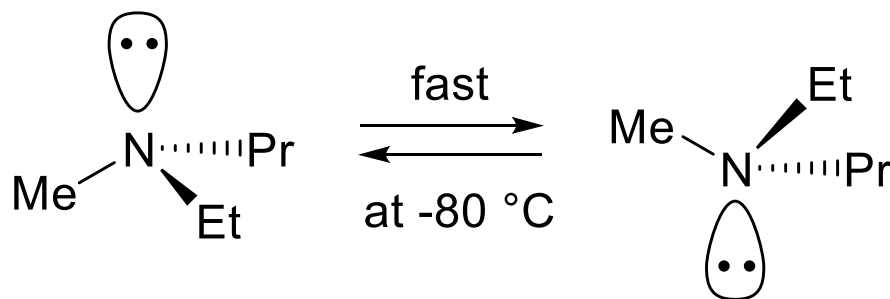
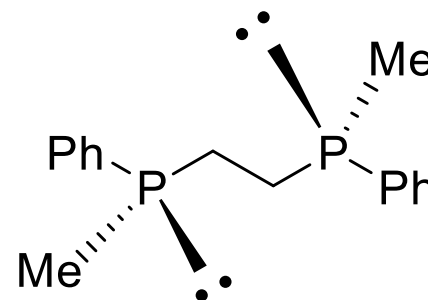
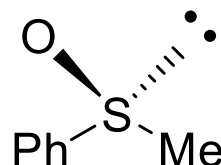
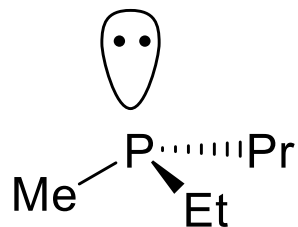
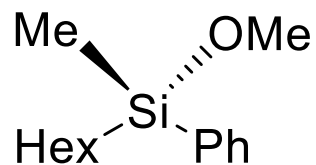

$$\Delta E^* = 5 \text{ Kcal/mol}$$

2×10^{11} inversions every second!

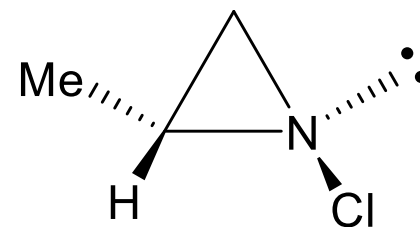

configurationally
stereoisomer

Nomenclature of stereoisomers

The Cahn-Ingold-Prelog rules (**CIP** rules)

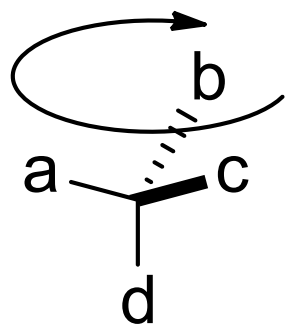

(R)

clockwise

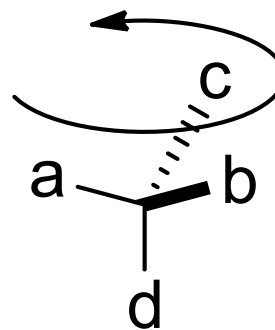

(S)

anti-clockwise

Nomenclature of stereoisomers

1. Highest atomic number: $I > Br > Cl$; $D > H$

2. $CH_2Br > CH_2Cl > CH_2OH > CH_2CH_3 > CH_3$

$CH_2Br > CCl_3$!

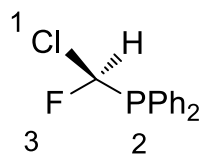

(R)

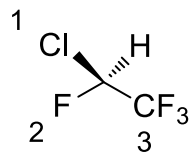

(S)

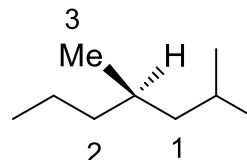

(R)

3. The case of multiple bonds

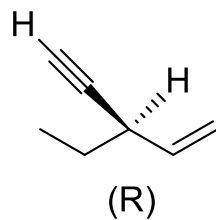
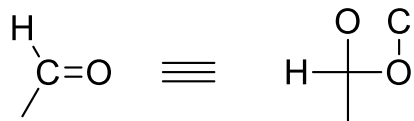

(R)

≡

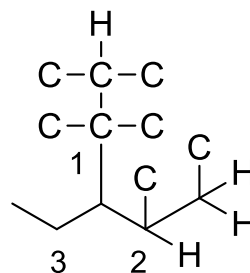

Nomenclature of stereoisomers

Ascending Order of Priority of Some Common Groups, According to the Sequence Rules

1. Electronic pair	21. $-\text{C}\equiv\text{CH}$	41. $-\text{NHCH}_3$
2. $-\text{H}$	22. $-\text{C}_6\text{H}_5$	42. $-\text{NHCH}_2\text{CH}_3$
3. $-\text{D}$	23. $-\text{C}_6\text{H}_4\text{CH}_3\text{-}p$	43. $-\text{NHCOCH}_3$
4. $-\text{T}$	24. $-\text{C}_6\text{H}_4\text{NO}_2\text{-}p$	44. $-\text{NHCOC}_6\text{H}_5$
5. $-\text{CH}_3$	25. $-\text{C}_6\text{H}_4\text{CH}_3\text{-}m$	45. $-\text{N}(\text{CH}_3)_3$
6. $-\text{CD}_3$	26. $-\text{C}_6\text{H}_4\text{NO}_2\text{-}m$	46. $-\text{N}^+(\text{CH}_3)_3$
7. $-\text{CH}_2\text{CH}_2\text{CH}_3$	27. $-\text{C}\equiv\text{C}-\text{CH}_3$	47. $-\text{N}=\text{O}$
8. $-\text{CH}_2\text{CH}_2\text{CH}_2\text{CH}_3$	28. $-\text{C}_6\text{H}_4\text{CH}_3\text{-}o$	48. $-\text{NO}_2$
9. $-\text{CH}_2\text{CH}_2\text{CH}(\text{CH}_3)_2$	29. $-\text{C}_6\text{H}_4\text{NO}_2\text{-}o$	49. $-\text{OH}$
10. $-\text{CH}_2\text{CH}(\text{CH}_3)_2$	30. $-\text{C}_6\text{H}_3(\text{NO}_2)_2$	50. $-\text{OMe}$
11. $-\text{CH}_2\text{CH}=\text{CH}_2$	31. $-\text{CHO}$	51. $-\text{OCOCH}_3$
12. $-\text{CH}_2\text{C}(\text{CH}_3)_3$	32. $-\text{COCH}_3$	52. $-\text{OSO}_2\text{CH}_3$
13. $-\text{CH}_2\text{C}\equiv\text{CH}$	33. $-\text{COC}_6\text{H}_5$	53. $-\text{F}$
14. $-\text{CH}_2\text{C}_6\text{H}_5$	34. $-\text{CO}_2\text{H}$	54. $-\text{SH}$
15. $-\text{CH}(\text{CH}_3)_2$	35. $-\text{CO}_2\text{CH}_3$	55. $-\text{SCH}_3$
16. $-\text{CH}=\text{CH}_2$	36. $-\text{CO}_2\text{CH}_2\text{CH}_3$	56. $-\text{S}(\text{O})\text{CH}_3$
17. $-\text{CH}(\text{CH}_3)\text{CH}_2\text{CH}_3$	37. $-\text{CO}_2\text{C}_6\text{H}_5$	57. $-\text{SO}_2\text{CH}_3$
18. $-\text{C}_6\text{H}_{11}\text{-}c$	38. $-\text{CO}_2\text{C}(\text{CH}_3)_3$	58. $-\text{Cl}$
19. $-\text{CH}=\text{CH}-\text{CH}_3$	39. $-\text{NH}_2$	59. $-\text{Br}$
20. $-\text{C}(\text{CH}_3)_3$	40. $-\text{NH}_3^+$	60. $-\text{I}$

Nomenclature of stereoisomers

4. R,S-nomenclature for compounds with an axial chirality

allenes:

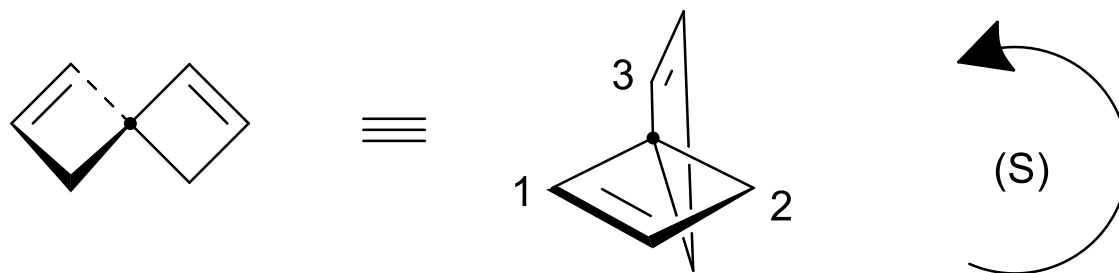
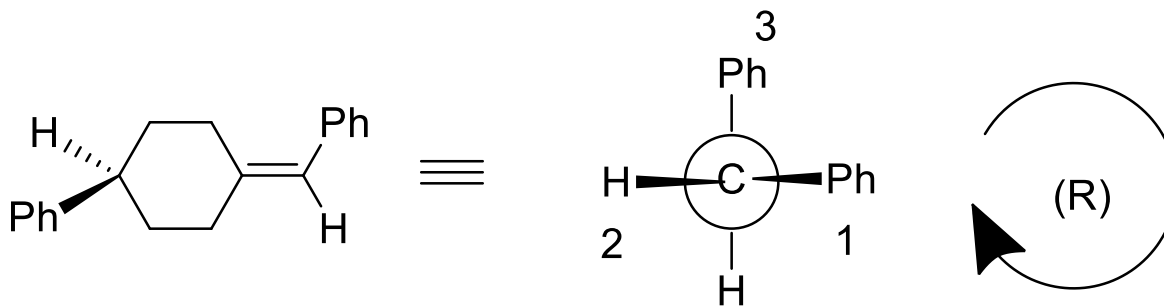
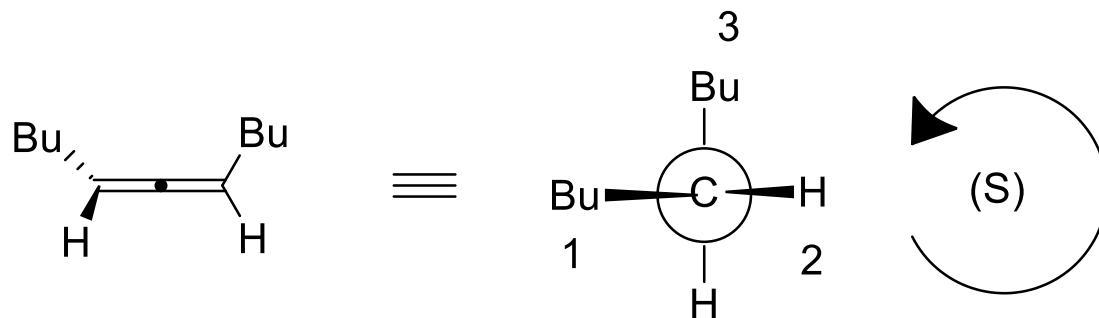

Prochirality: homotopicity, enantiotopicity, diastereotopicity

Relevance of symmetry:

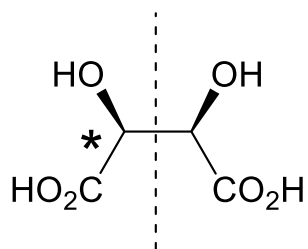

σ_h

2 stereocenters but only 3 stereoisomers

meso

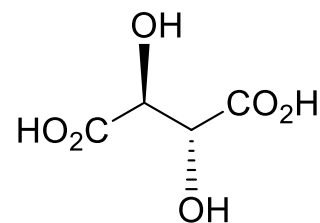
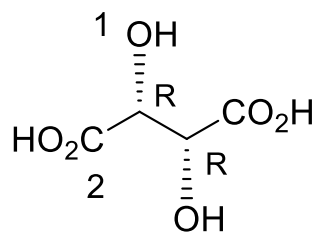
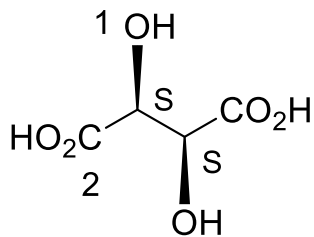

meso

Pseudo-asymmetric and chirotopic centers

Fischer-Projection

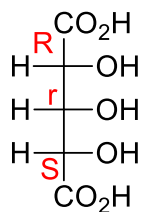

meso-1

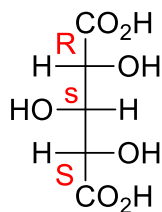

meso-2

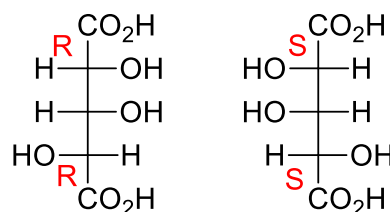

identical
to

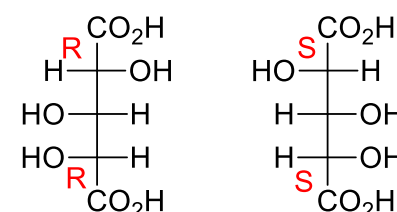

2 diastereomeric achiral molecules with a pseudo-asymmetric center

2 enantiomeric chiral molecules with a chirotopic center

chiral molecules with a chirotopic center

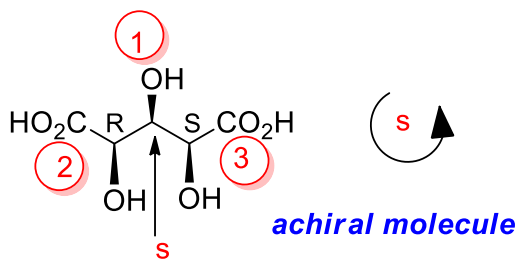

a **pseudo-asymmetric center** is a stereogenic center in an achiral environment

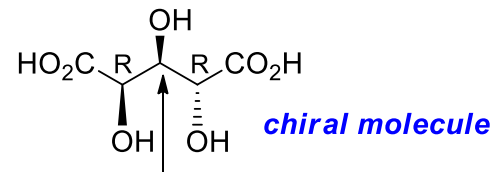

a **chirotopic center** is a non-stereogenic center in a chiral environment

a chiral center requires a chiral environment and to be stereogenic (surrounded by 4 different substituents)
a **chirotopic center** or a **pseudo-asymmetric center** are not a chiral center

Molecules with a chirotopic center or a chirotopic center

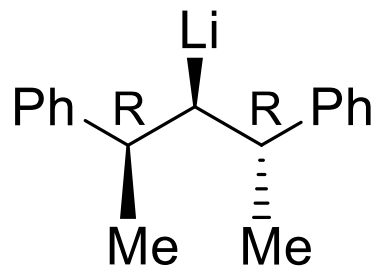

chiral configurational stable molecule

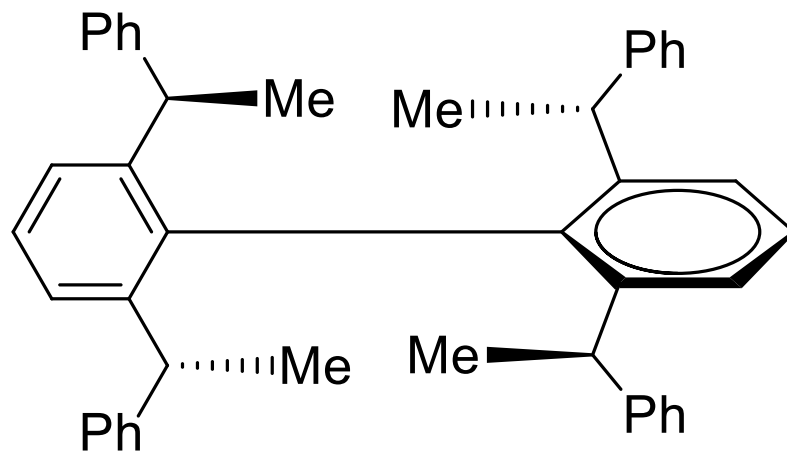

chirotopic chirality axis

Symmetry and stereochemistry

Symmetric operations:

1. C_n : n-fold rotation axes: rotation by an angle $360^\circ/n$

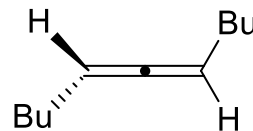
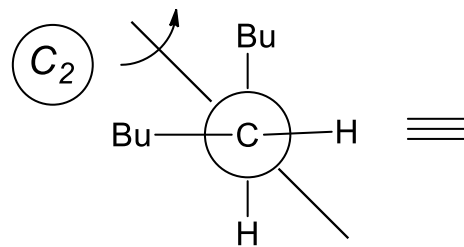
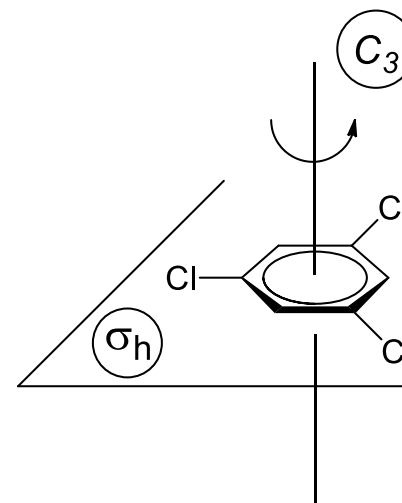
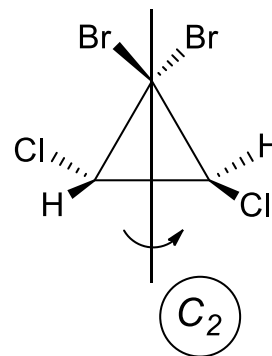
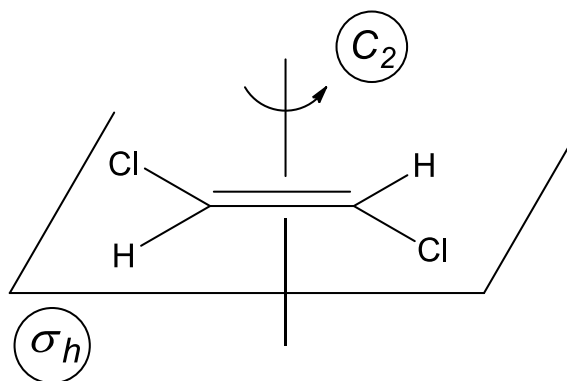
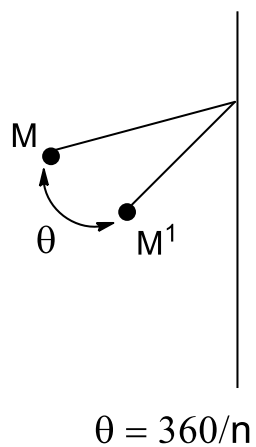

Symmetry and stereochemistry

2. σ_h : mirror plane

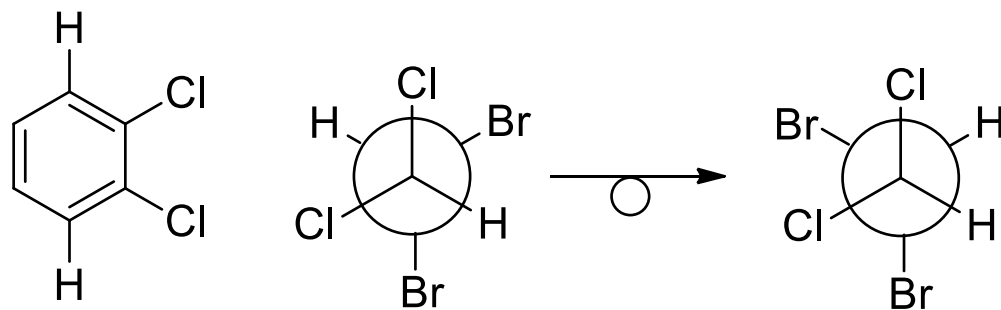
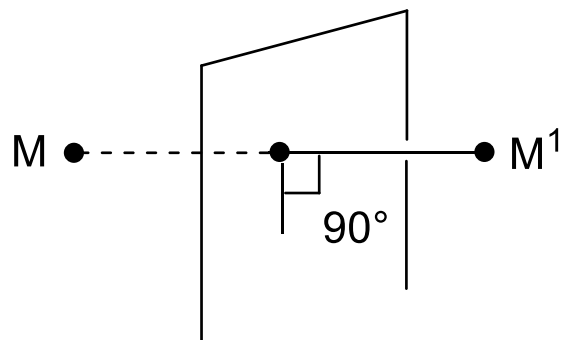

Symmetry and stereochemistry

3. Rotating mirror axis

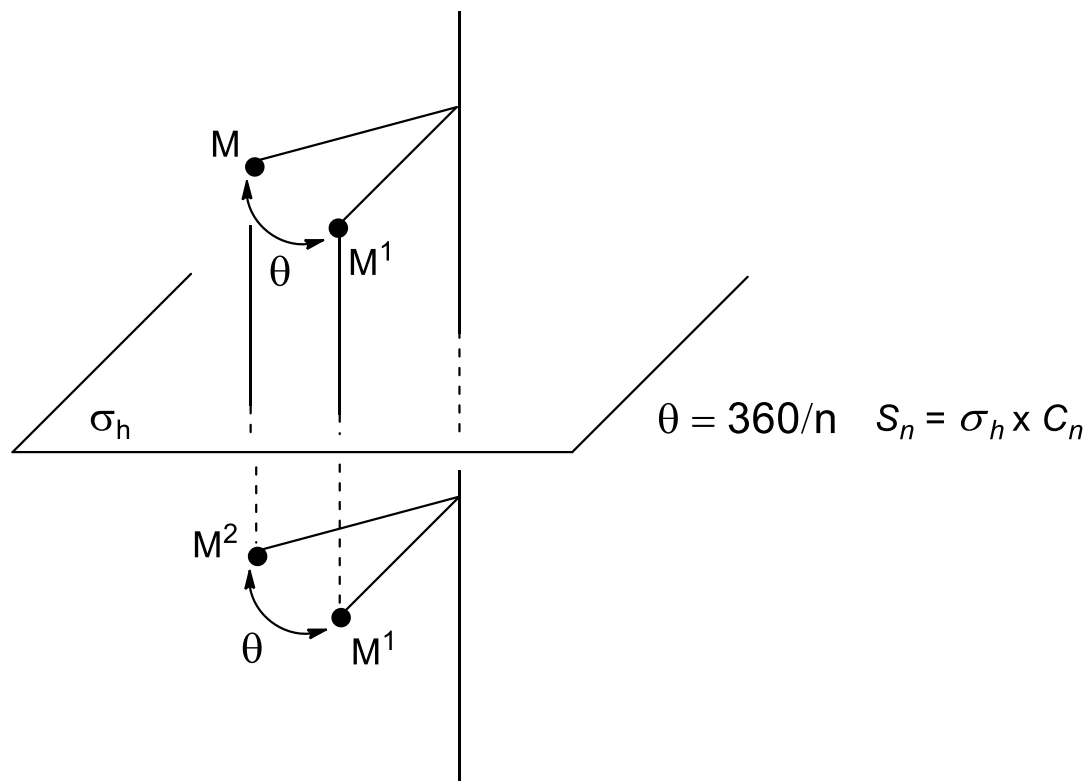

Symmetry and stereochemistry

Rotating mirror axis

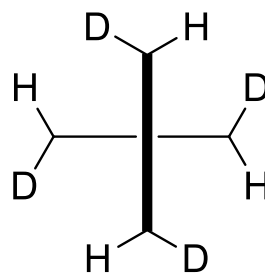
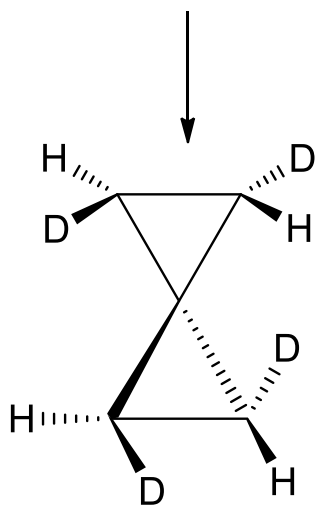

$$S_4 = C_4 \times \sigma_h$$

Symmetry and stereochemistry

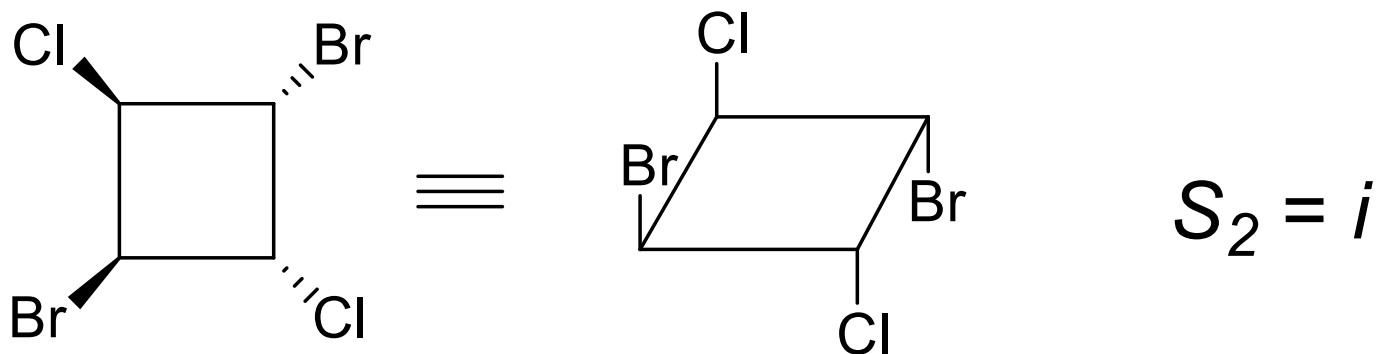

- molecules possessing C_n symmetry operations are chiral
- molecules possessing σ_h or S_n symmetry operations are achiral

Heterotopic groups and faces (Prochirality)

Two identical groups in one molecule can be either **homotopic**, **enantiotopic** or **diastereotopic** and show the corresponding properties.

Definition: The groups are **homotopic** if there can be transformed into each other by a symmetry operation C_n

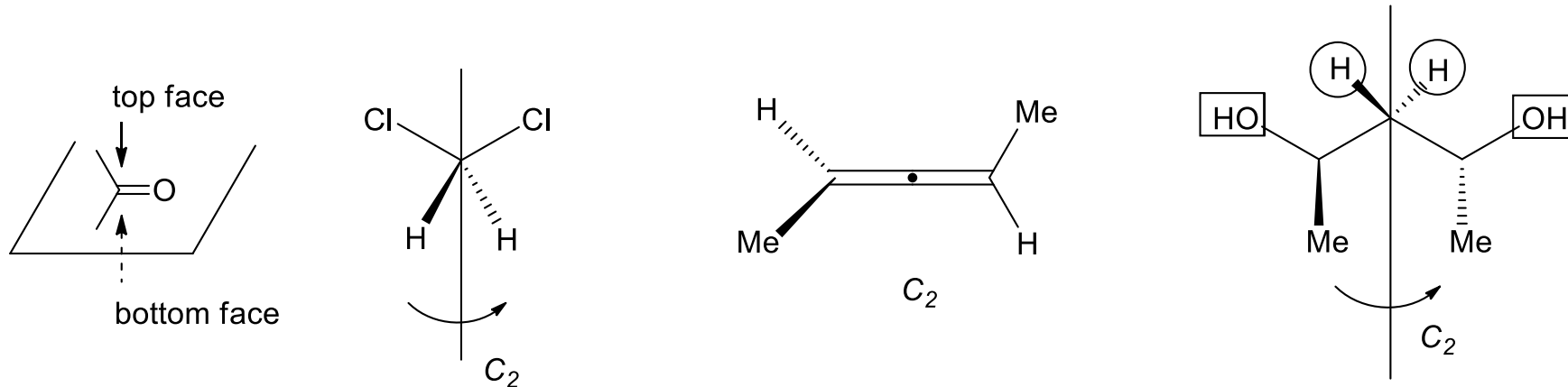

The reactivity of homotopic groups is the same towards all reagents. It is not possible to make a chemical distinction between homotopic groups.

Homotopic groups and faces

Substitution test: The substitution of an homotopic group by another group leads to the same molecule

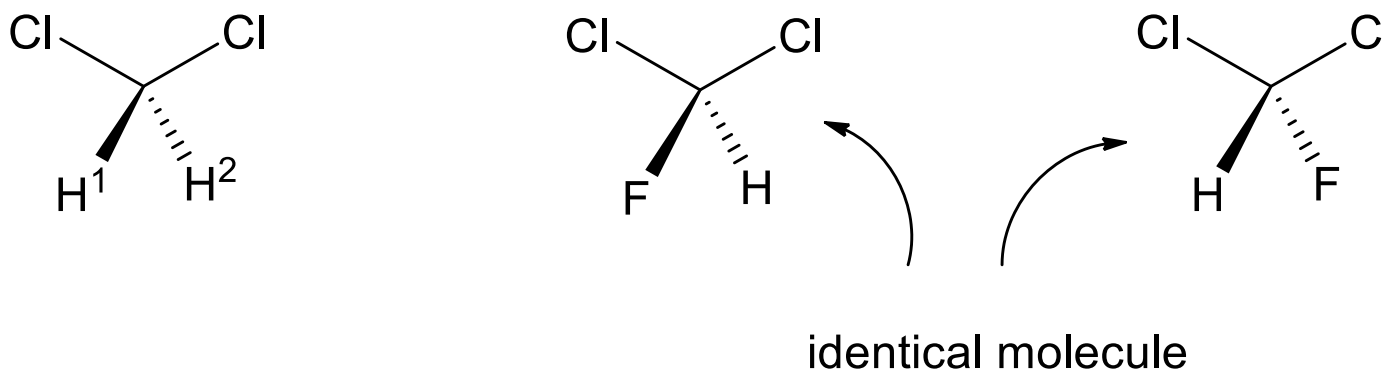

Feature: Homotopic groups and faces cannot be distinguished by any reagent.

The same chemical behaviour towards all reagents is observed.

Homotopic faces of a molecule

Homotopic faces: two faces are homotopic, if the plane defined by the two faces contains a C_2 axis.

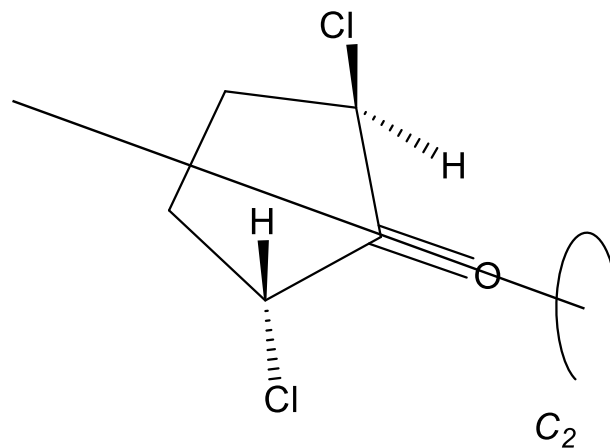
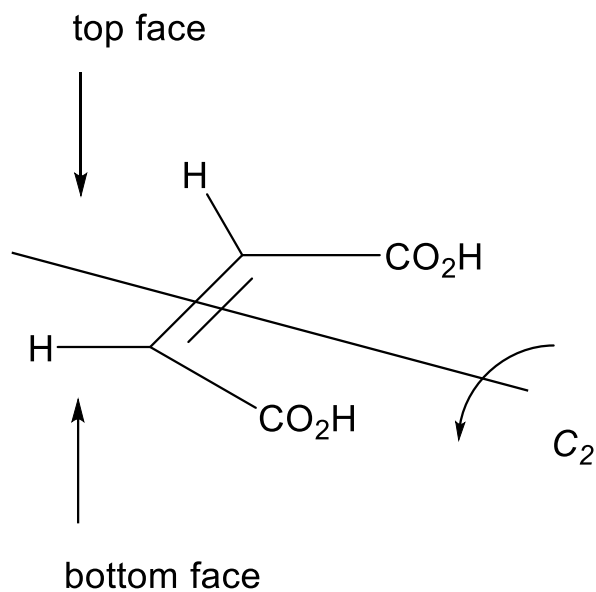

Enantiotopic groups and faces

Definition: The two groups in a molecule are enantiotopic, if they can be converted into one another by a S_n - or σ_h -operation.

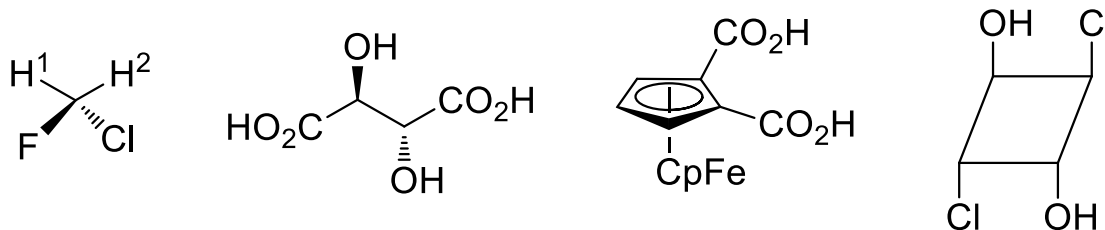

Enantiotopic groups are always found in achiral molecules.

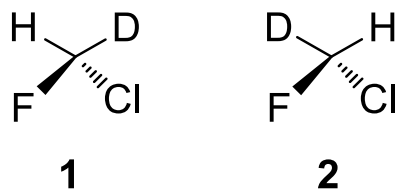

molecules **1** and **2**
are enantiomer

Substitution test: The substitution of one group of two enantiotopic groups gives two enantiomeric compounds.

Enantiotopic groups and faces

Enantiotopic faces are 2 faces that are defined by a plane of symmetry.

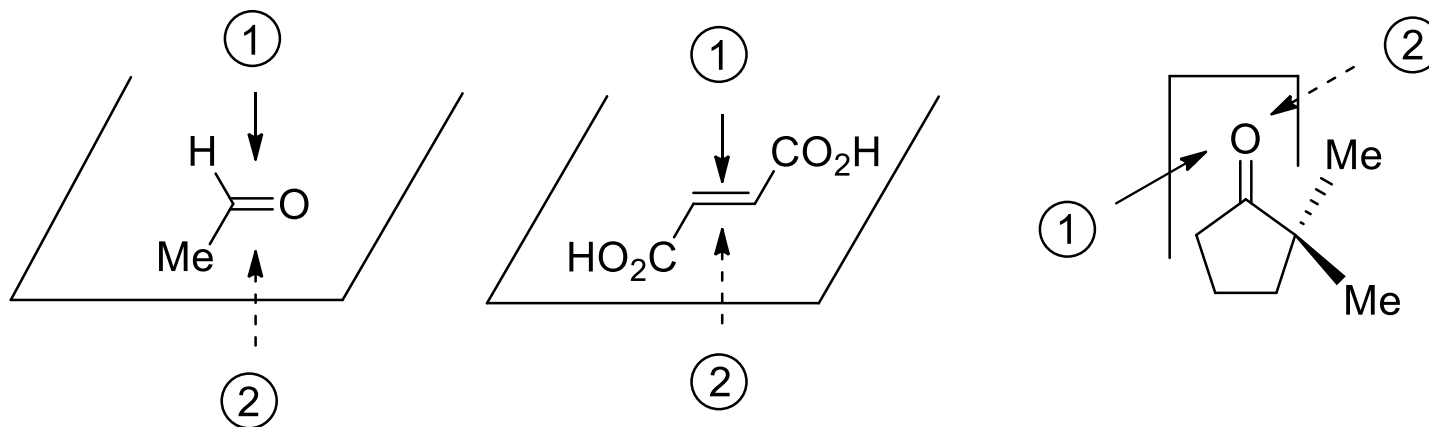

Features: Only chiral reagents can distinguish between enantiotopic groups. Achiral reagents can not differentiate between enantiotopic groups and faces.

Diastereotopic groups and faces

Diastereomeric groups can be transformed into one another only by the identity symmetry operation.

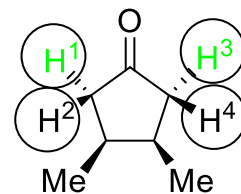
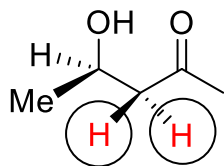
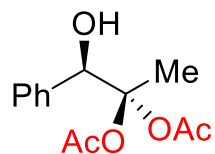

H¹ and H³ (or H² and H⁴) are enantiotopic groups
H¹ and H² (or H³ and H⁴) are diastereotopic groups

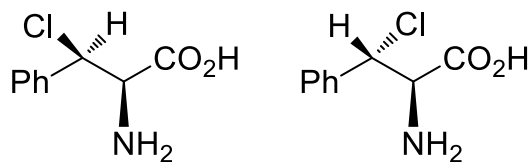
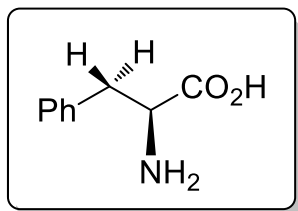

Substitution test:
provides two diastereoisomers.

Features: 2 diastereotopic groups and faces are distinguished by any reagent.

Diastereotopic faces are defined by a plane which is not a symmetry plane.

Additions to homotopic and enantiotopic faces

molecule with homotopic faces

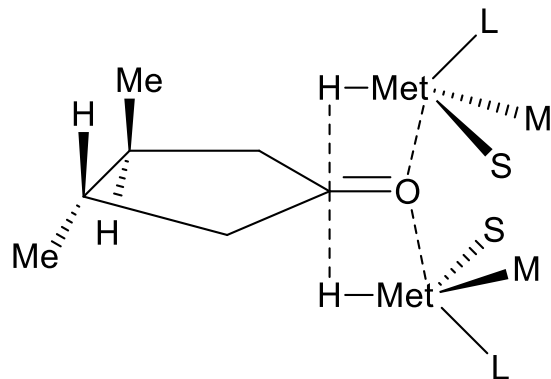

identical transition states
the same activation energy

molecule with enantiotopic faces

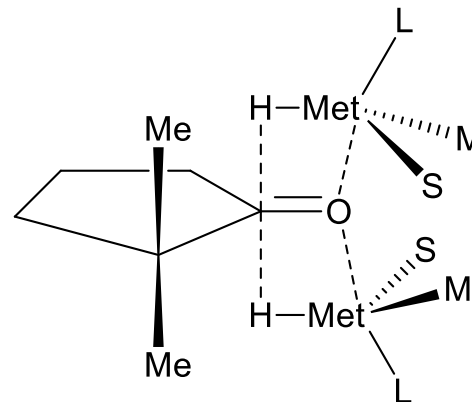

diastereomeric transition states
leads to activation energy

Topicity	Groups	Faces	Reactivity
Homotopic groups and faces	C_n	C_2	no differentiation possible
Enantiotopic groups and faces	σ_h or S_n	σ_h	differentiation by chiral reagents (or catalysts)
Diastereotopic groups and faces	none	$\neq \sigma_h$	differentiation by any reagent

Enantiomers and racemates

Racemization: Processes which convert a pure enantiomer into a 1:1 mixture of enantiomers

racemization under basic conditions

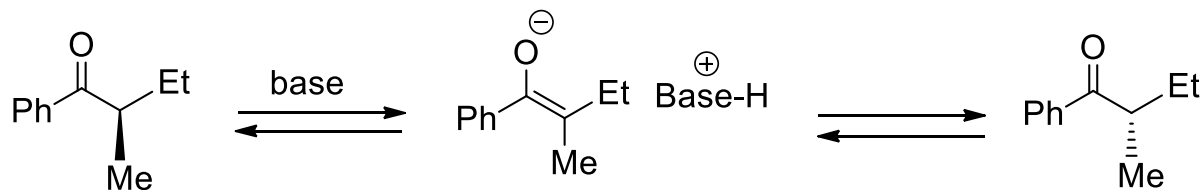

racemization under acidic conditions:

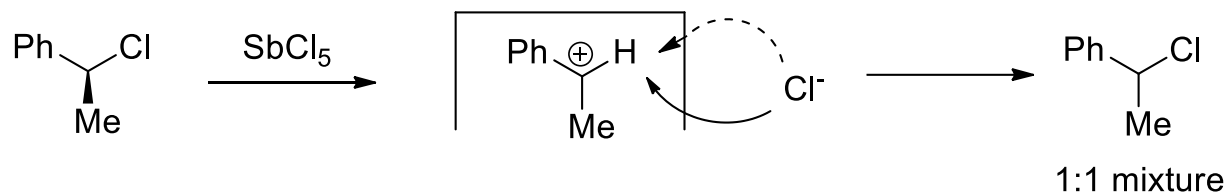

racemization under radical conditions:

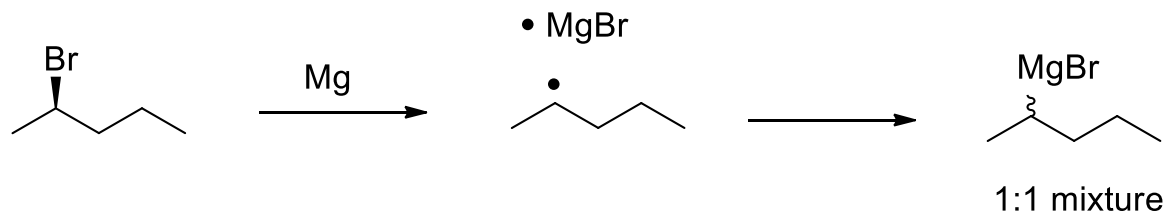

Racemization

Process which convert a pure enantiomer into the racemate

A racemization – process implies an achiral intermediate

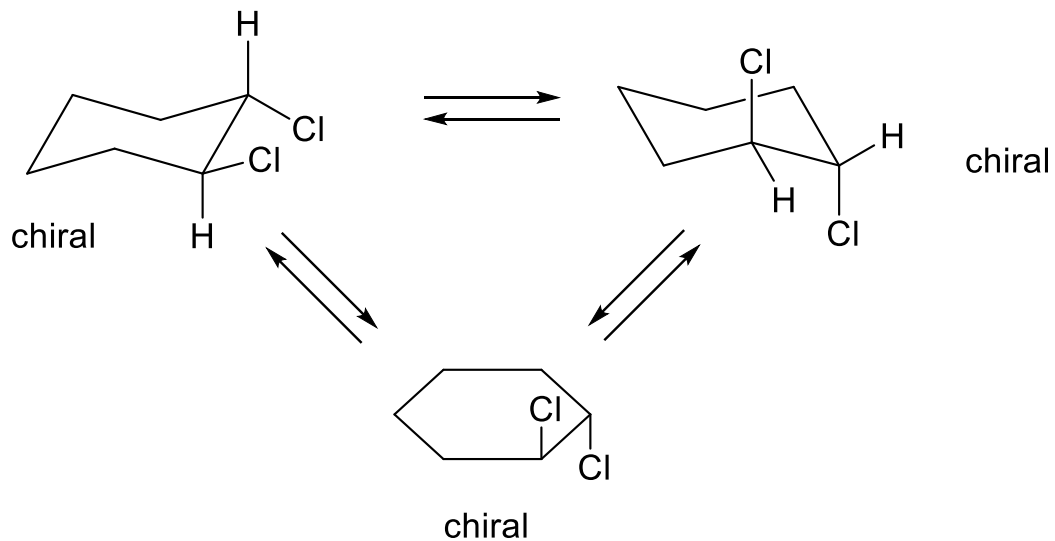
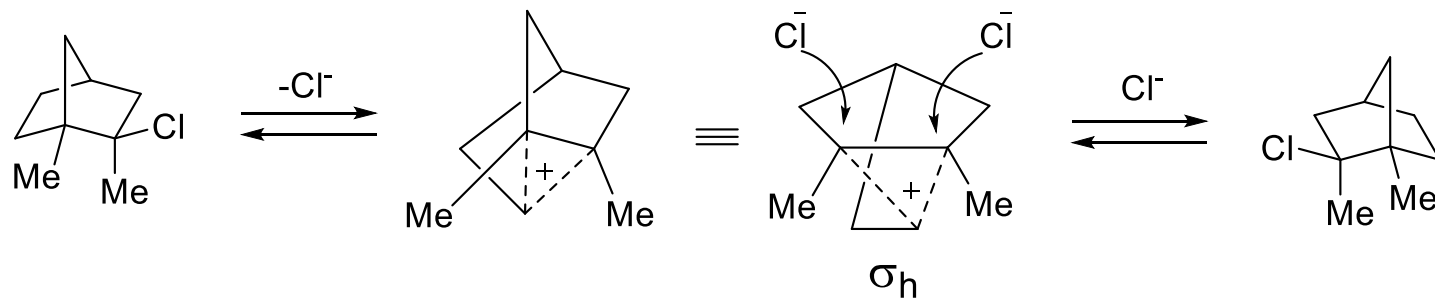

Racemization

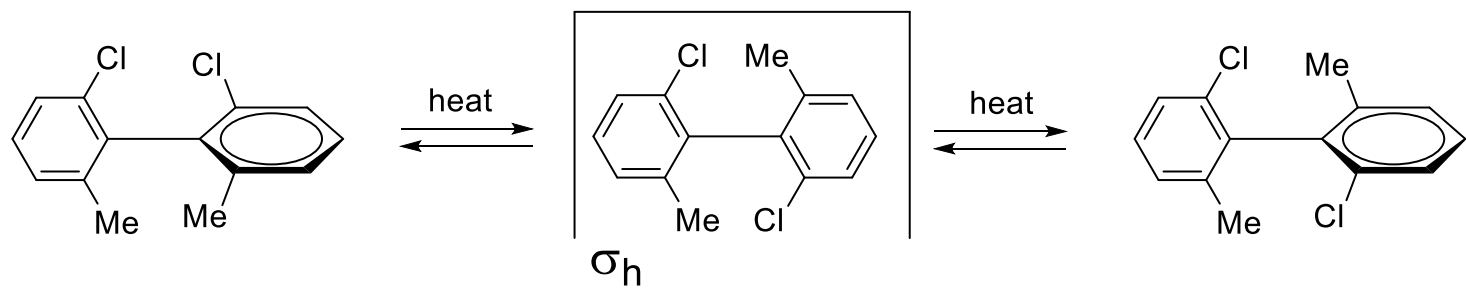

Racemization of Tröger's base

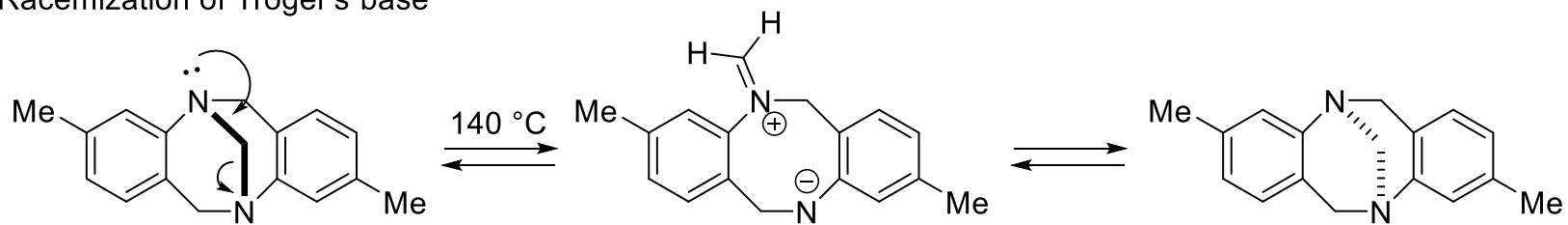

Epimerization of diastereoisomers

Epimerization: racemization of only one from several chiral centers.

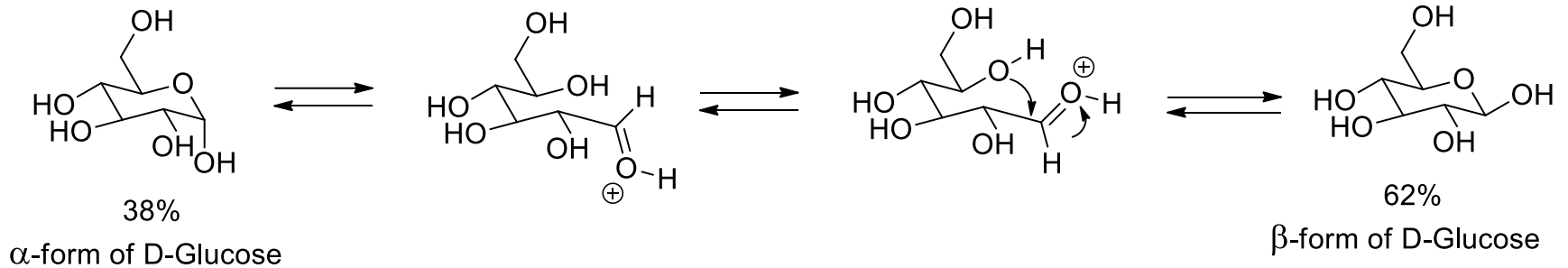
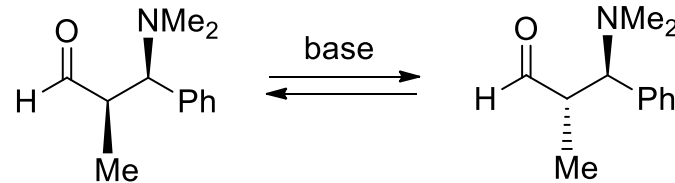

Selective inversion of the configuration at Csp³-centers

S_N2-substitutions :

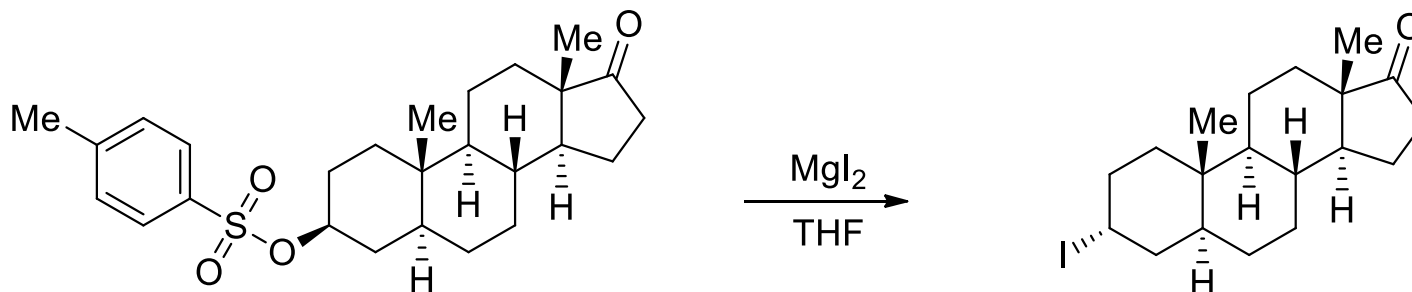
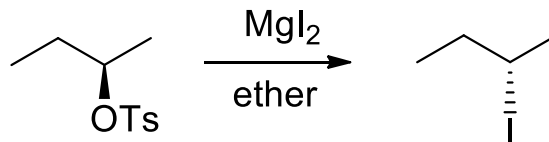

H.-J. Schneider, U. Buchheit, N. Becker, G. Schmidt, U. Siehlt, *J. Am. Chem. Soc.* **1985**, *107*, 1021-1039.

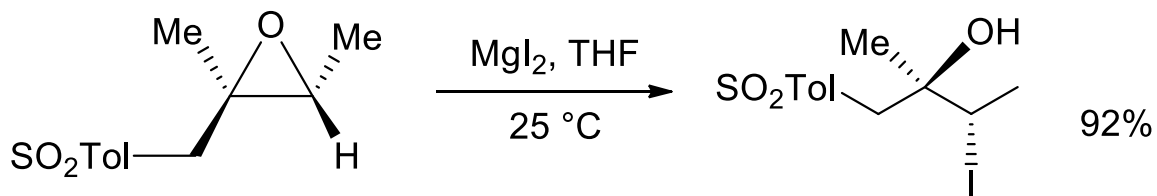

C. Banini, G. Righi, G. Sothiu, *J. Org. Chem.* **1991**, *56*, 6206.

Inversion of alcohols: Mitsunobu reaction

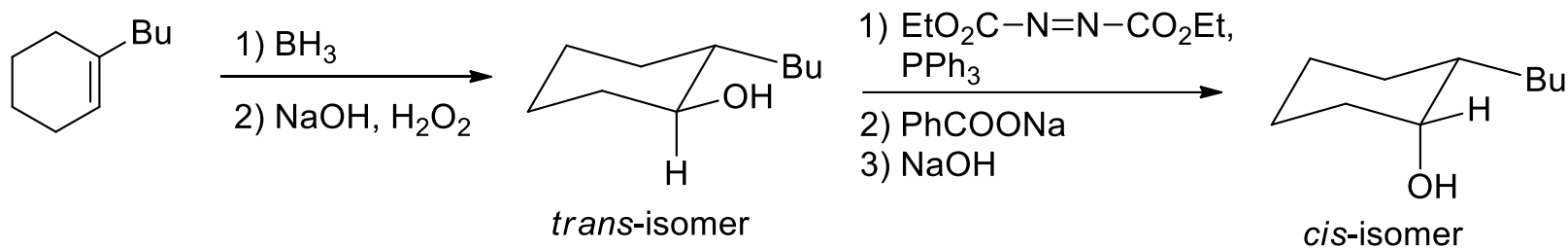

Mitsunobu reaction: D. L. Hughes, *Org. React.* **1992**, 42, 335-656.

S_Ni-reaction

S_Ni reaction

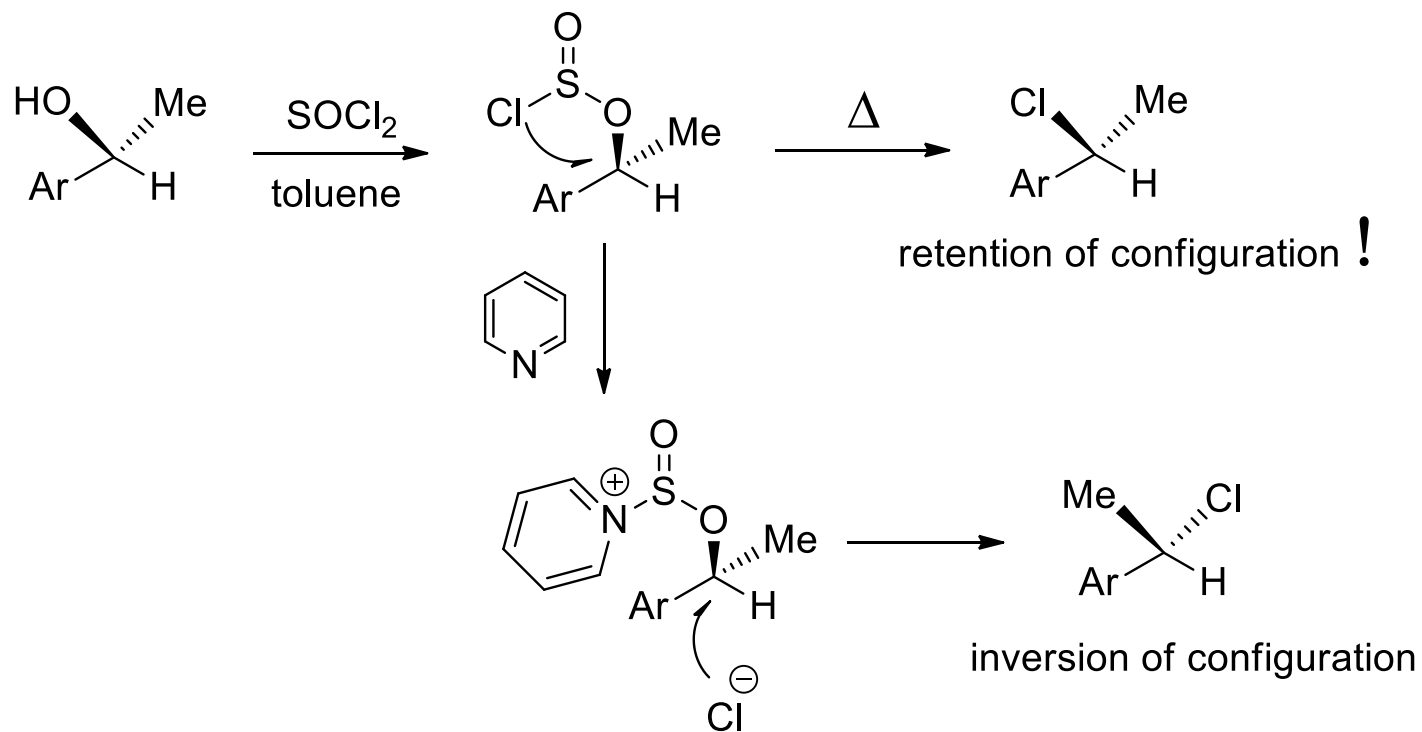

Substitution with retention of configuration

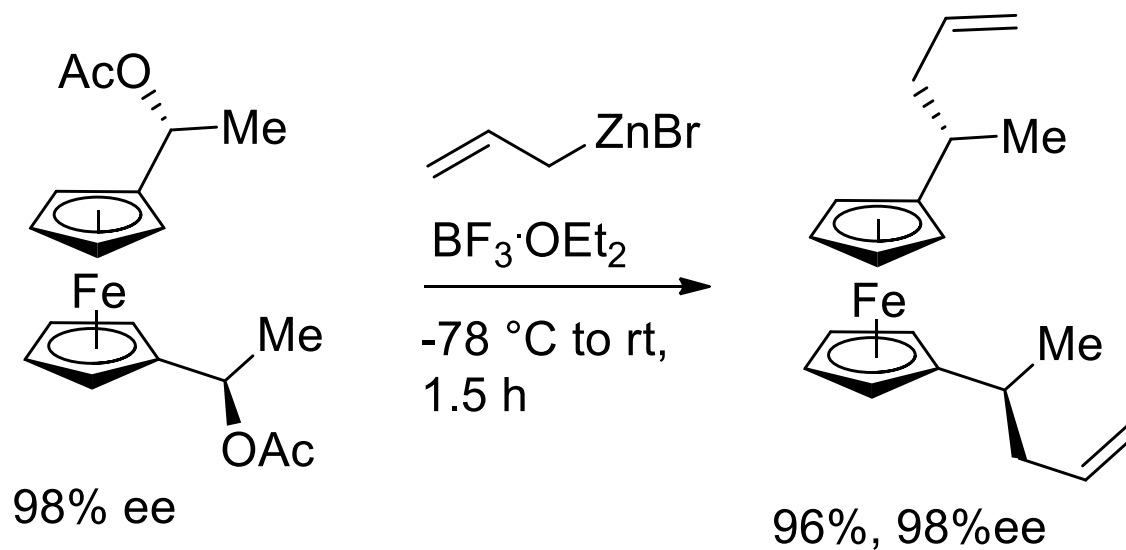
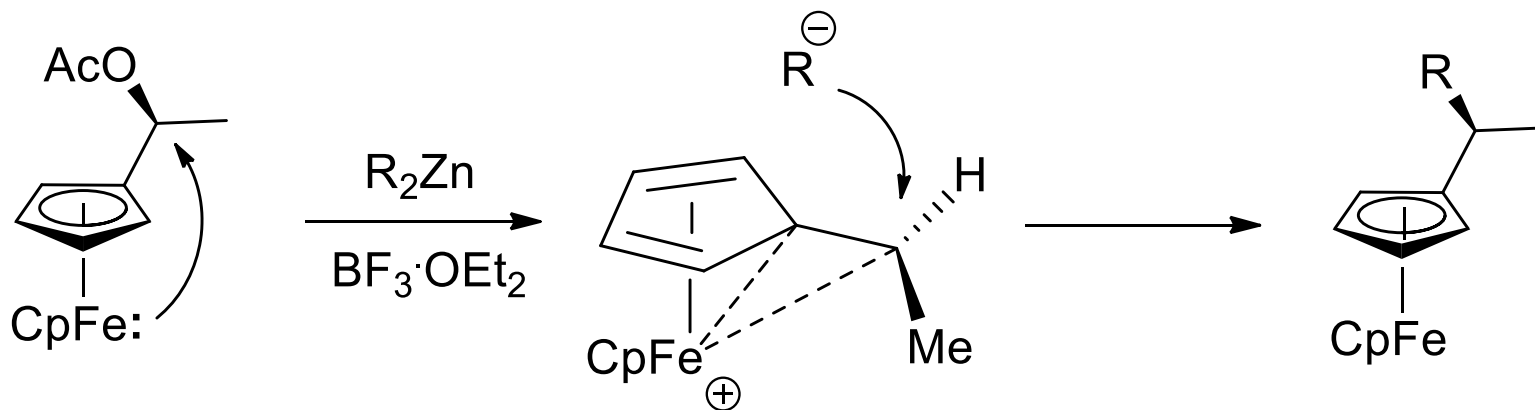

J. J. Almena Perea, T. Ireland, P. Knochel, *Tetrahedron Lett.* **1997**, 38, 5961-5964.

Methods for Racemate Resolution

Separation of enantiomers

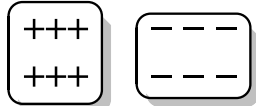
Conglomerates:  20% of all racemates

Racemates: 

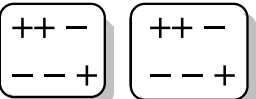
Pseudoracemates:  unordered crystals

- 1) Separation based on the crystal shape. Pasteur (1845): crystal picking. Triage
- 2) Selective crystallization using a seed crystal
Example: (+)-tartaric acid is easily crystallized by the addition of (-)-asparagine

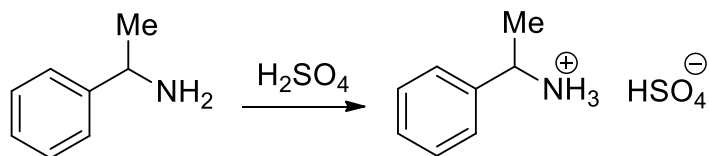

Mp of (-) or (+): 272 °C
Mp of (±): 245 °C

Resolution *via* separation of diastereomers

(±)-acids can be separated using chiral bases such as alkaloids: quinine, brucine, morphine.

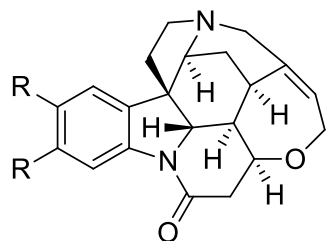
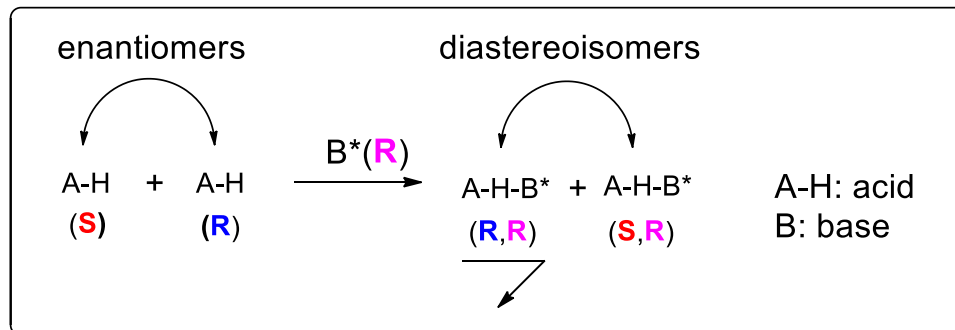

R = H : strychnine
R = OMe : brucine

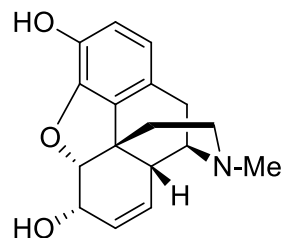

morphine

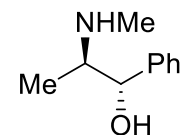

ephedrine

further example:

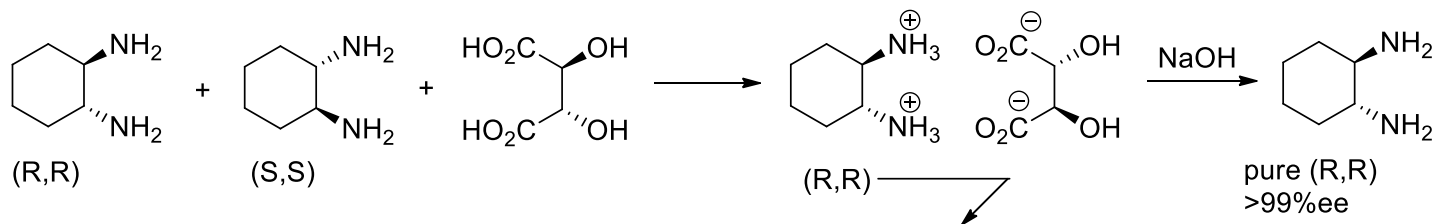

Resolution of 3-methyl-2-phenylbutanoic acid

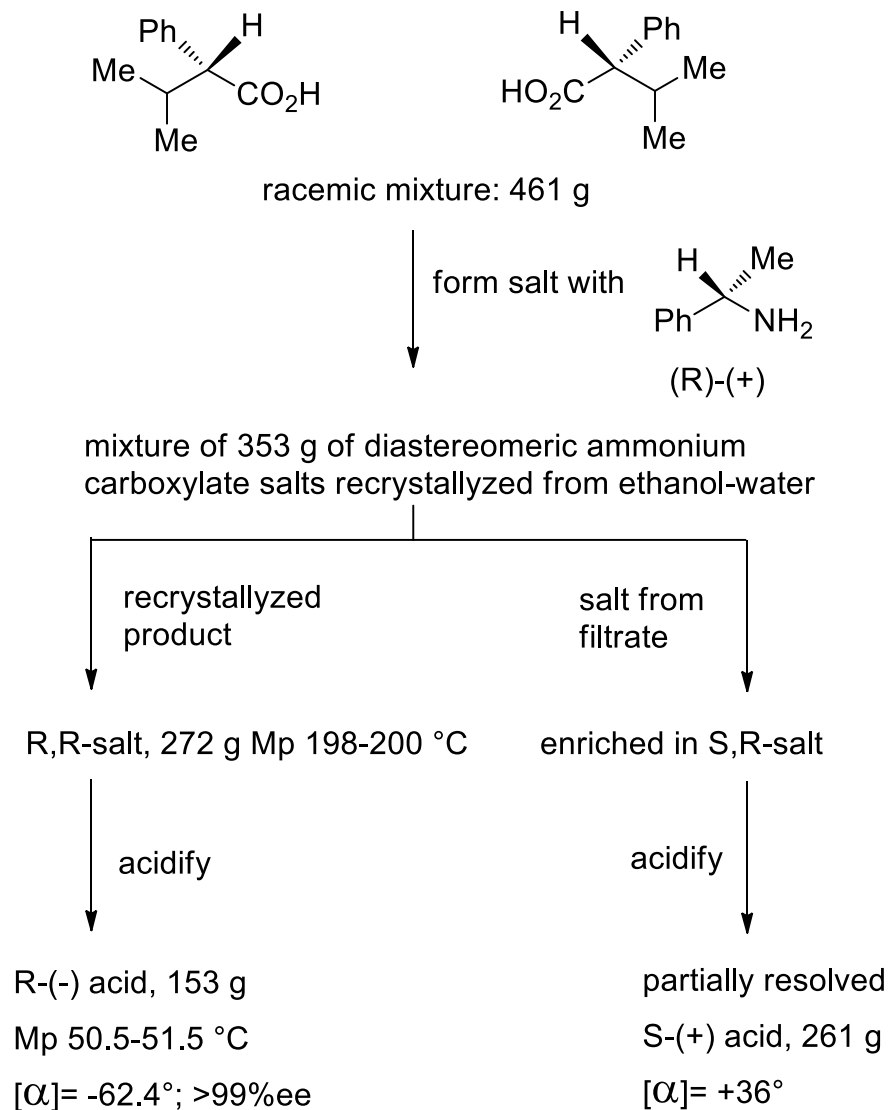

Resolution *via* separation of diastereomers

Commonly used resolving agents

For acids	For bases
<p>α-Methylbenzylamine α-Methyl-<i>p</i>-nitrobenzylamine α-Methyl-<i>p</i>-bromobenzylamine 2-Aminobutane <i>N</i>-Methylglucamine Dehydroabietylamine α-(1-Naphthyl)ethylamine <i>threo</i>-2-amino-1-(<i>p</i>-nitrophenyl)-propane-1,3-diol Cinchonine Cinchonidine Quinine Ephedrine</p>	<p>1-Camphor-10-sulphonic acid Malic acid Mandelic acid α-Methoxyphenylacetic acid α-Methoxy-α-trifluoromethylphenylacetic acid 2-Pyrrolidone-5-carboxylic acid Tartaric acid</p>

Separation of enantiomers

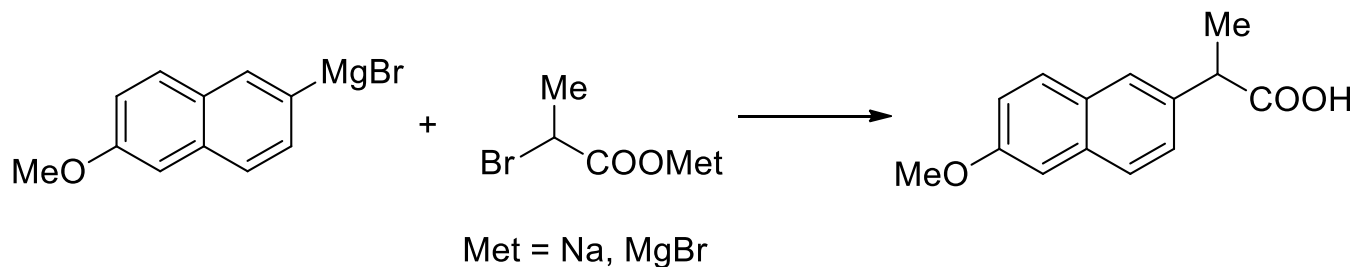

The resolution of enantiomers by preferential crystallization is the most common method used in industry:

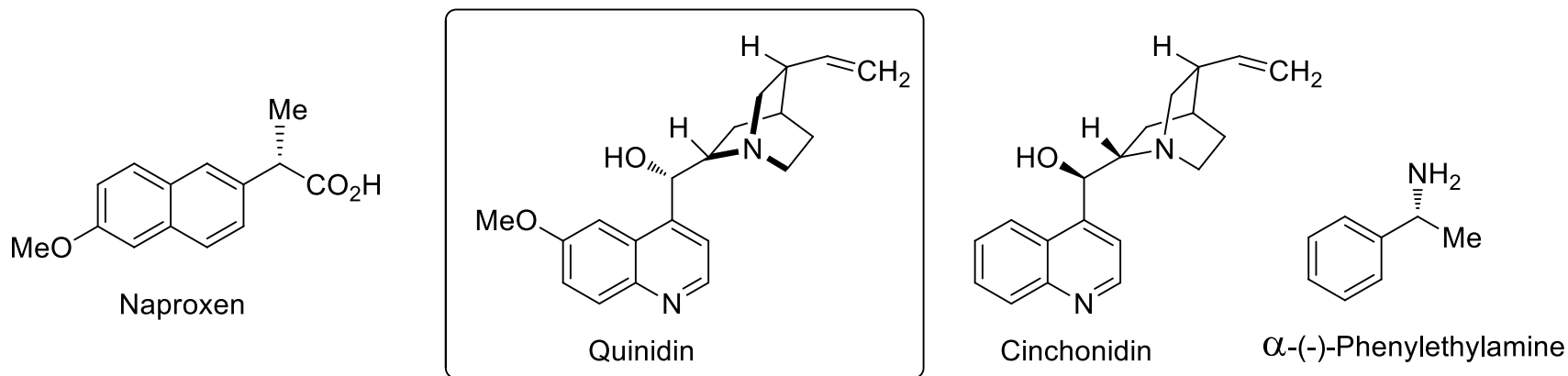

Resolution of Naproxen using Quinidine

C. G. M. Villa and S. Panossian, *Chirality in industry*, **1992**, Vol. 1, 303.

Preparation of acidic resolution agents

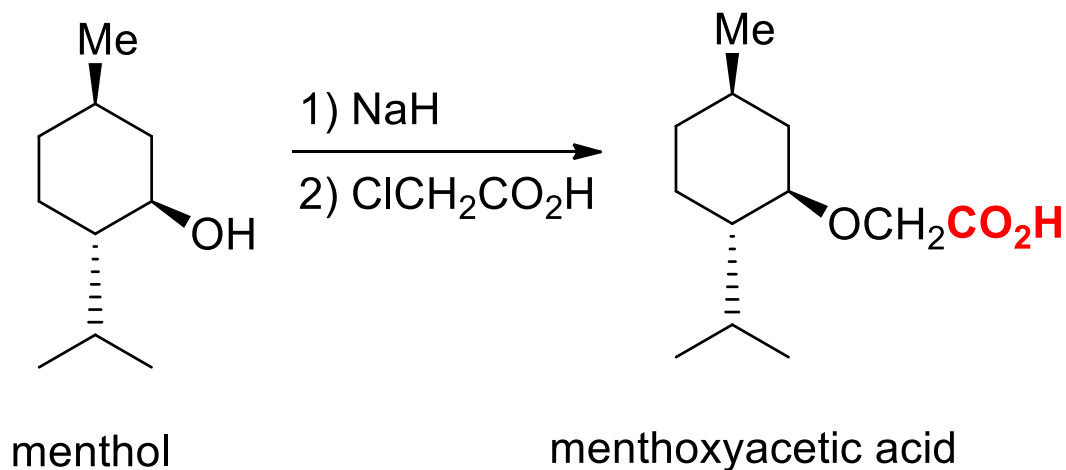
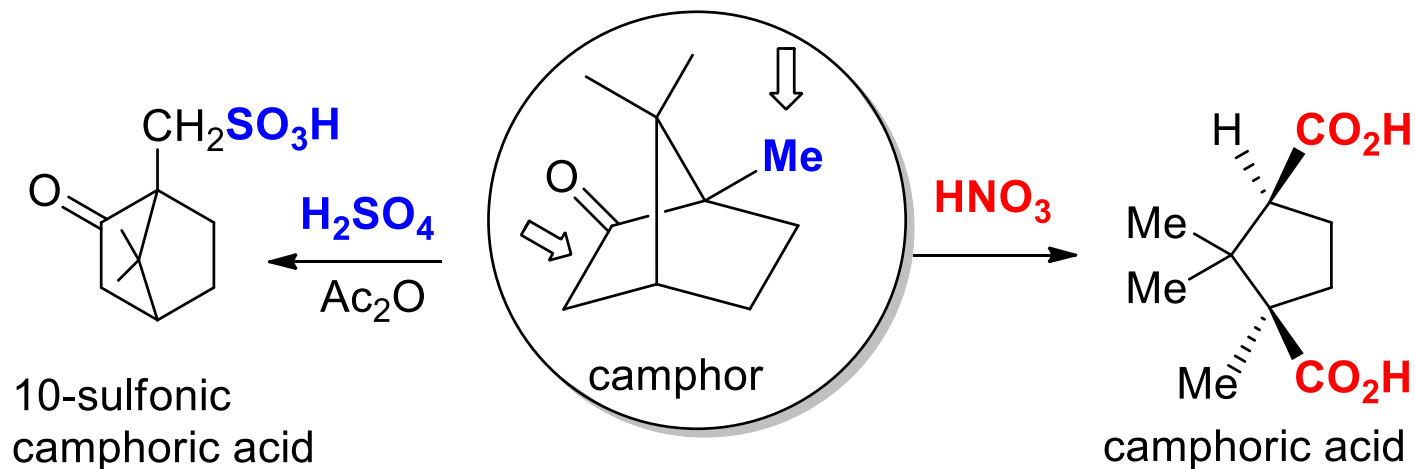

Extension to the resolution of alcohols

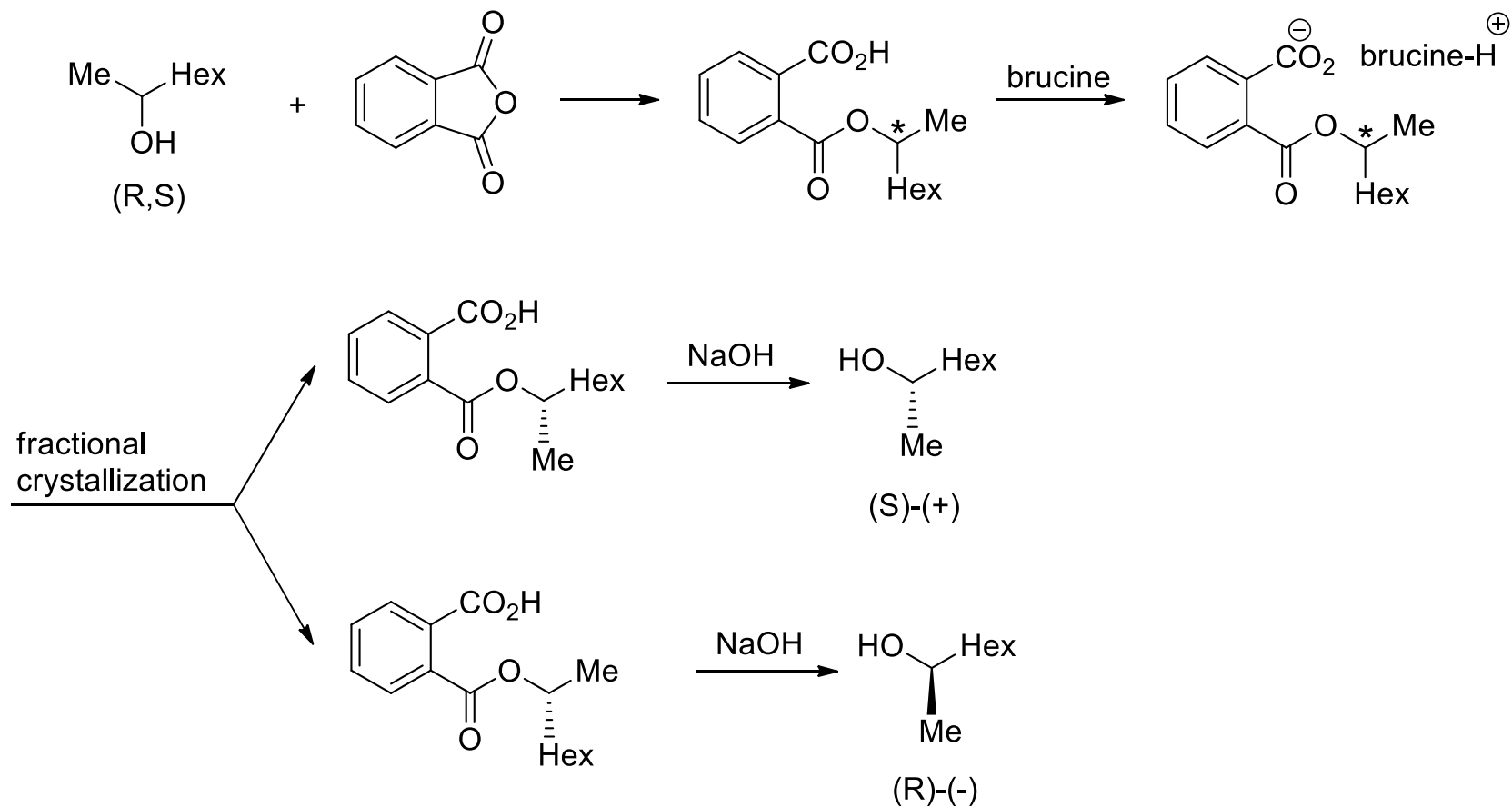

Resolution of ketones by the formation of diastereoisomers

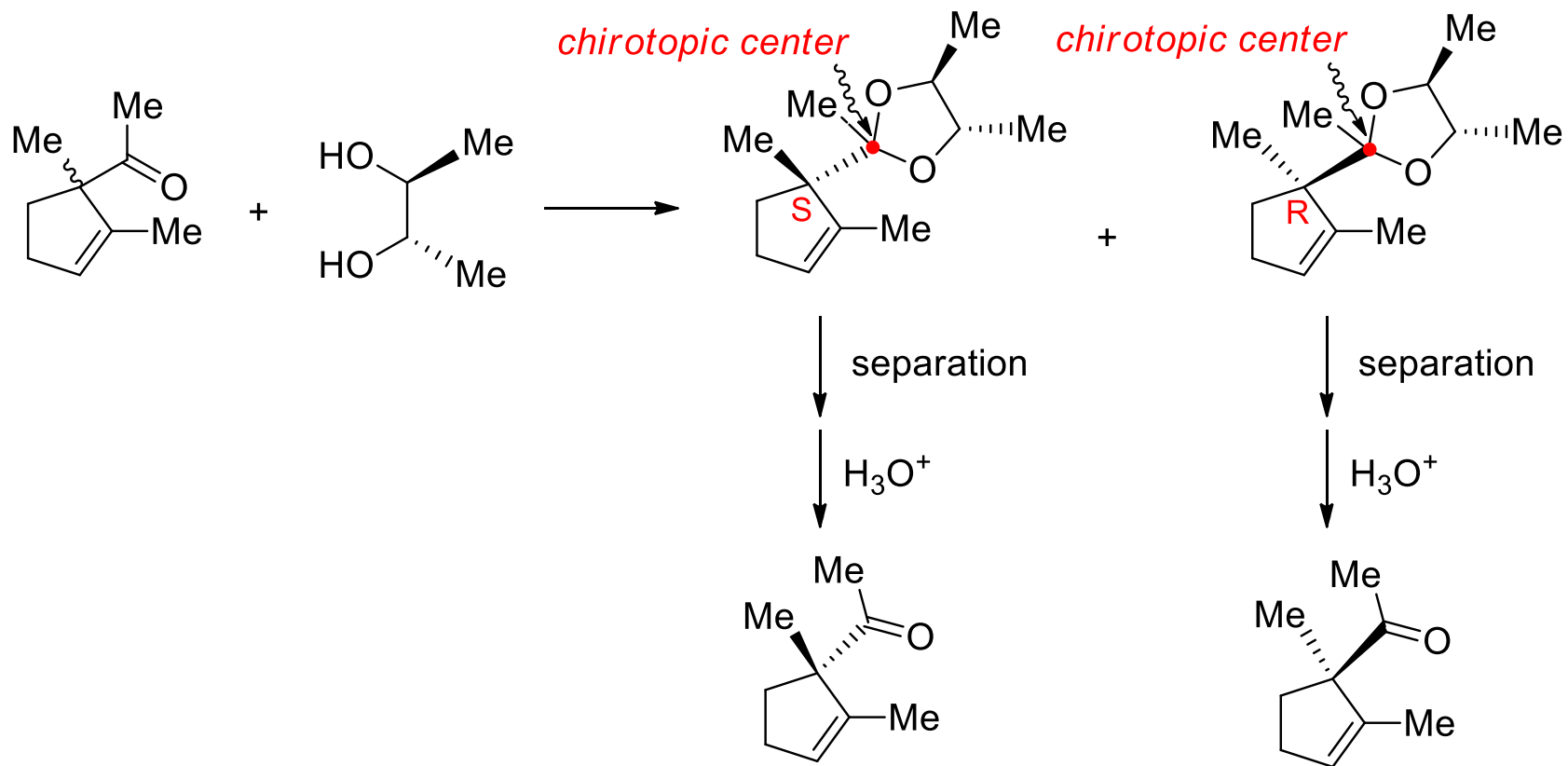

The diastereomeric ketals are separated by chromatography and hydrolyzed leading to the pure enantiomers

Resolution with *in situ* racemization

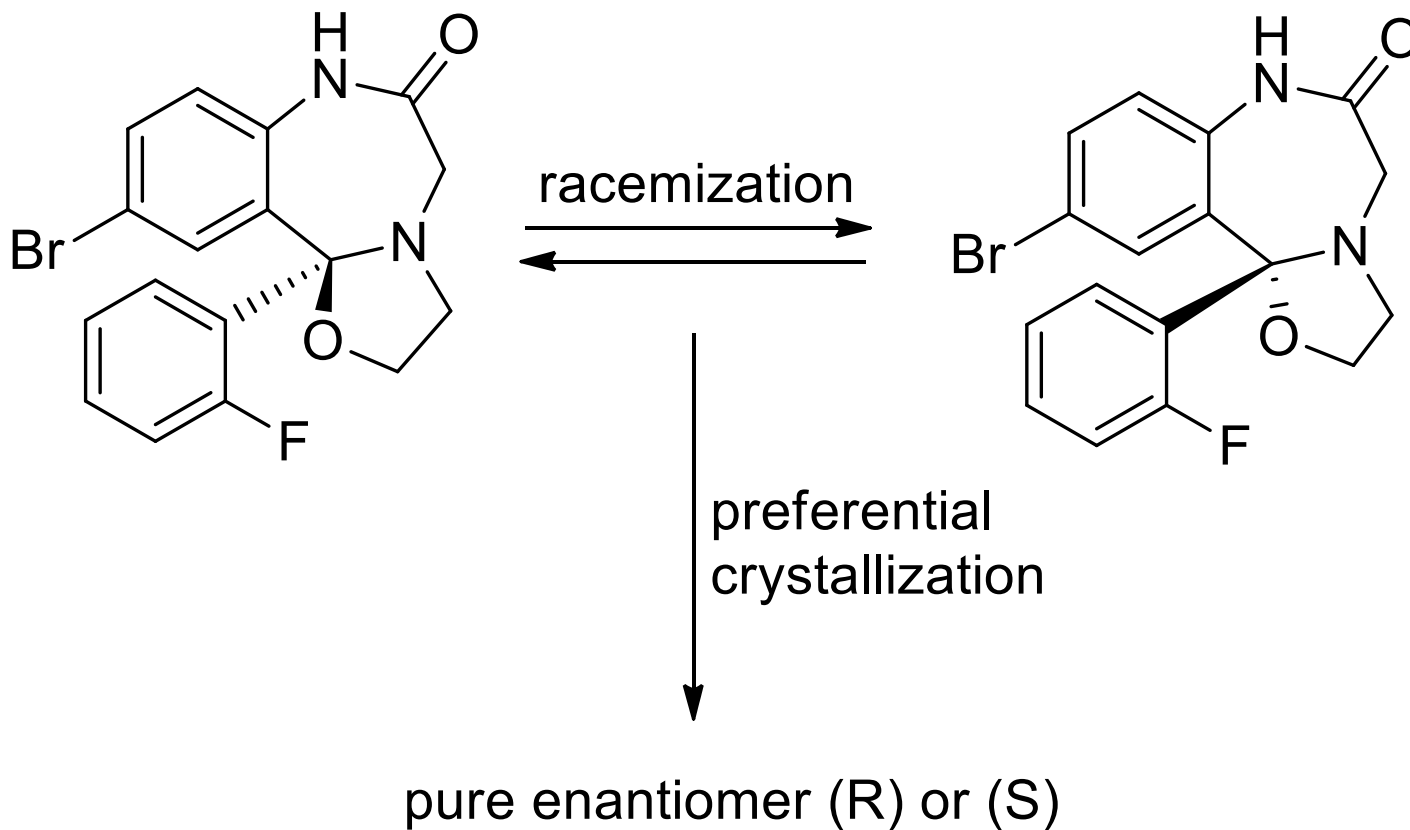

Y. Okada, T. Takebayashi, *Chem. Pharm. Bull.* **1988**, **36**, 3787.

Separation using a chiral chromatographic columns

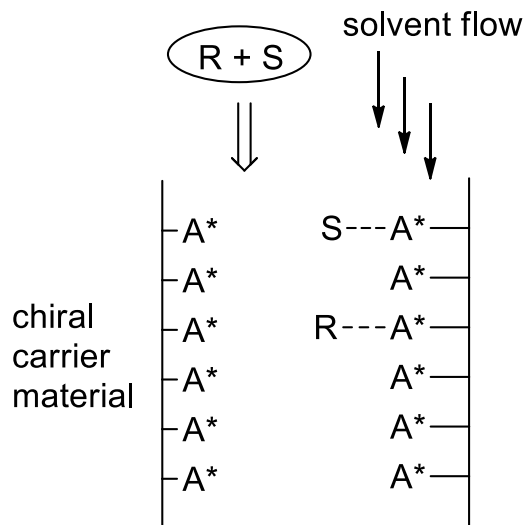

- Gas chromatography: the solvent is a gas
- HPLC (High Pressure Liquid Chromatography): the solvent is a mixture of liquids

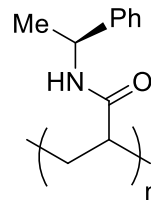
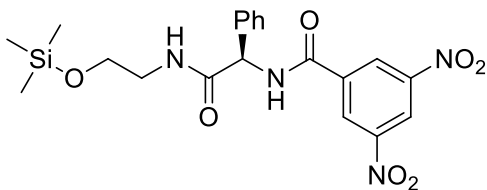
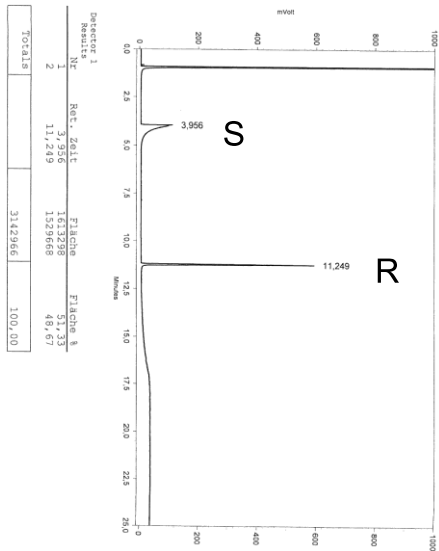

Chiral phases

polysaccharides (α -Cyclodextrin)

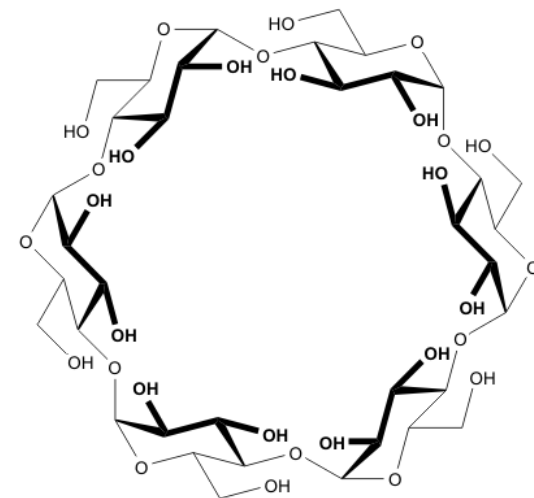

Enzymatic resolution: an example of kinetic resolution

Pasteur:

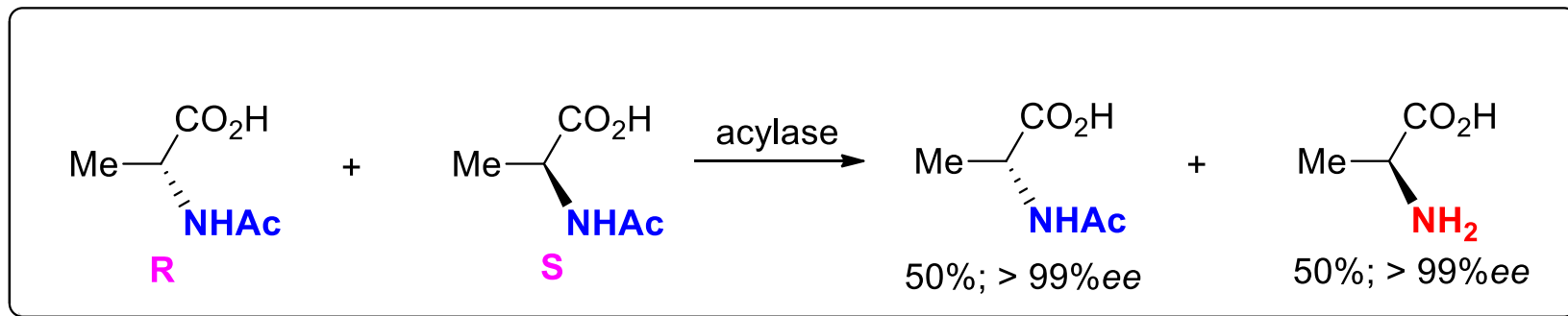
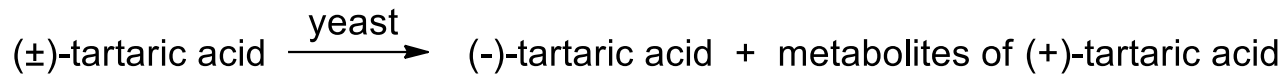

The two enantiomers react with different rates.

This differentiation is possible because a chiral reagent is used (an enzyme)

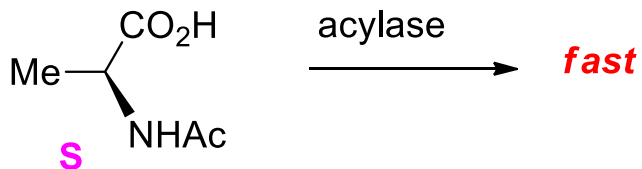
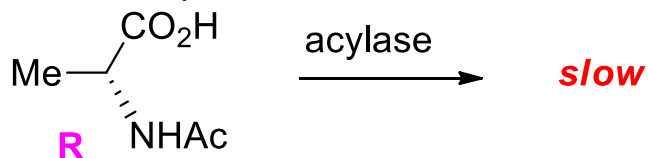

Application : Industrial use for the production of (D) - and (L)-amino acids

Kinetic resolution

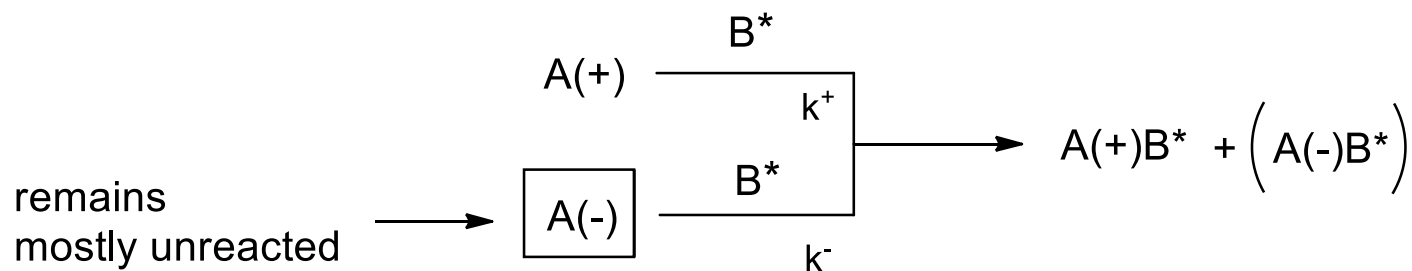

$$k^+ > k^-$$

$$S = \text{selectivity factor} = k^+/k^-$$

The kinetic resolution is only useful if the reaction rates of the two reactions are very different.

For example for a given conversion:

83%ee of the unreacted starting material is obtained if $k^+/k^- = S = 25$

93%ee of the unreacted starting material is obtained if $k^+/k^- = S = 100$

Dependence of enantiomeric excess on relative rate of reaction

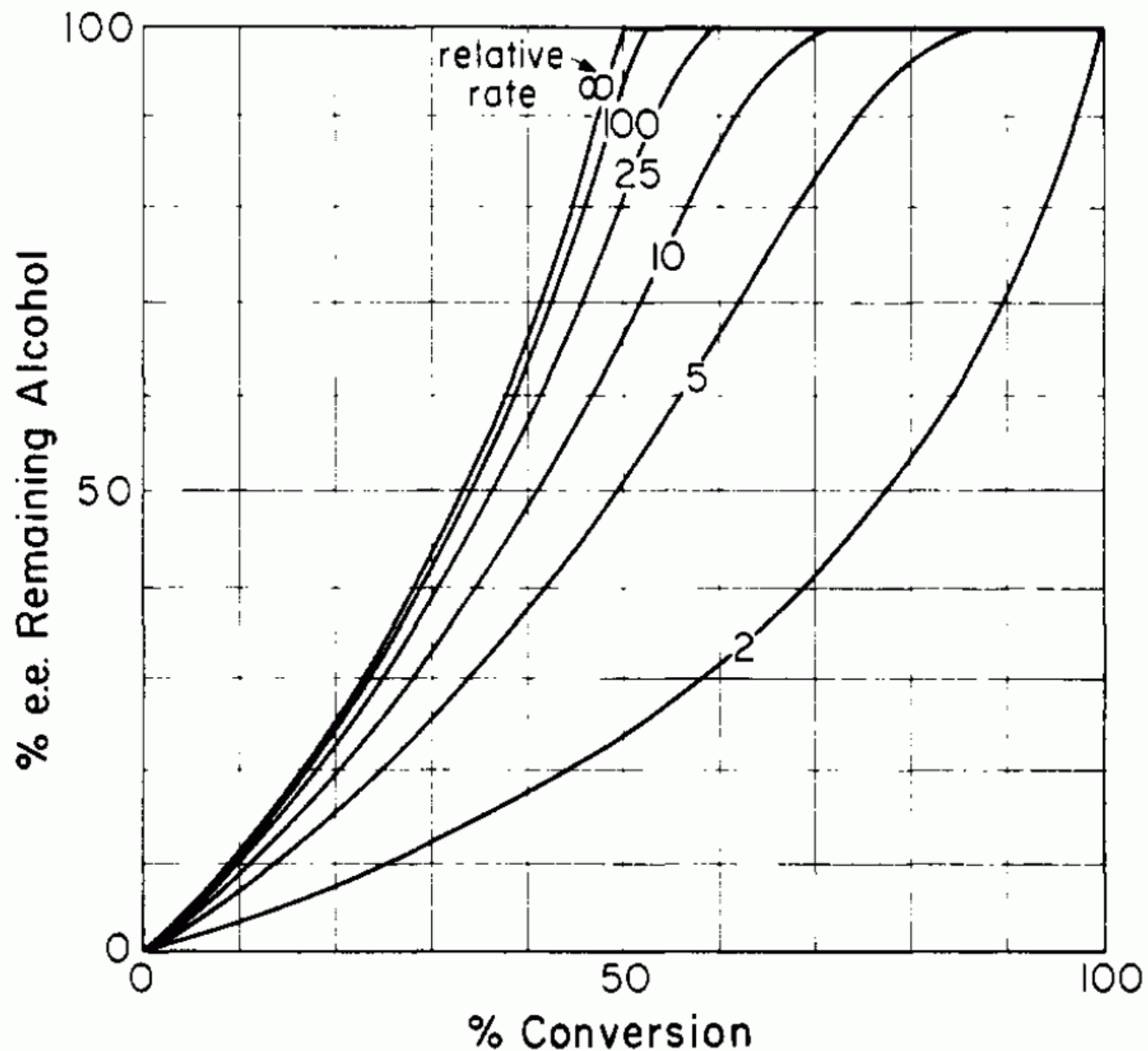

Kinetic resolution

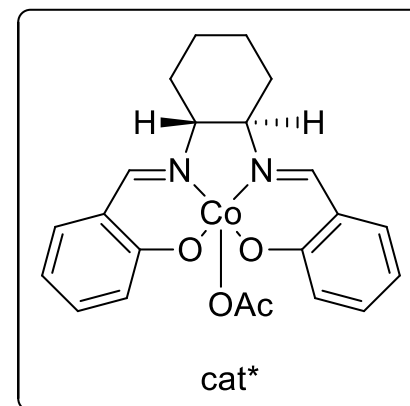
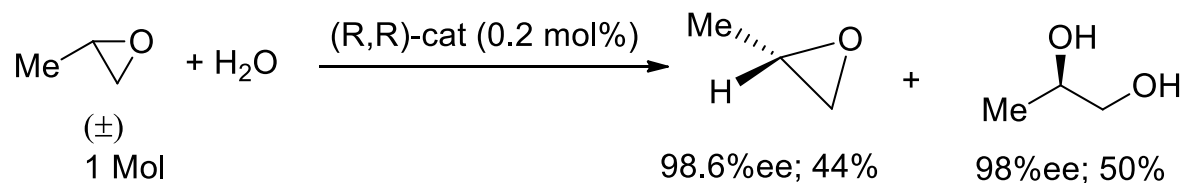

M. Tokunaga, J. F. Larrow, F. Kakiuchi, E. N. Jacobsen, *Science* **1997**, 277, 936.

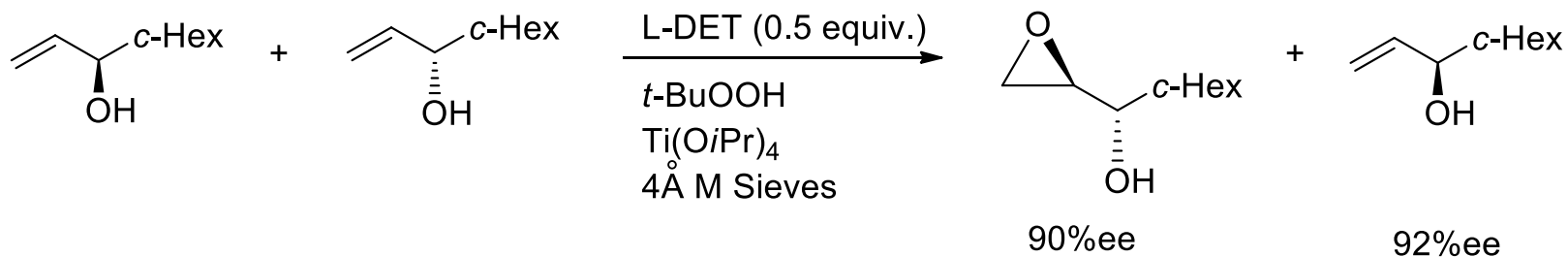

B. E. Rossiter, T. Katsuki, K. B. Sharpless, *J. Am. Chem. Soc.* **1981**, 103, 464.

P. R. Carlier, W. S. Mungall, G. Schroder, K. B. Sharpless, *J. Am. Chem. Soc.* **1988**, 110, 2978.

Examples of kinetic resolution

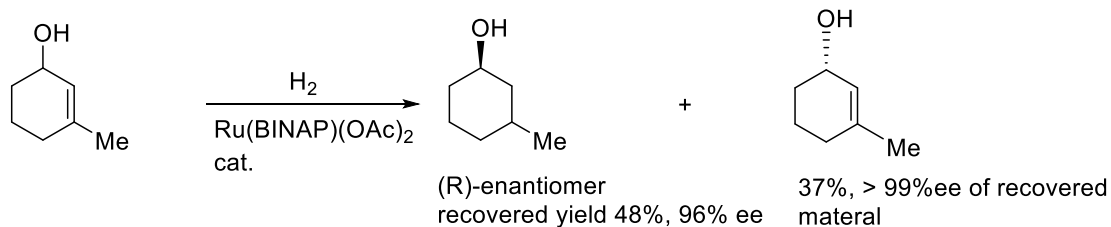

M. Kimura, I. Kasahara, K. Manabe, R. Noyori, H. Takaya, *J. Org. Chem.* **1988**, 53, 708.

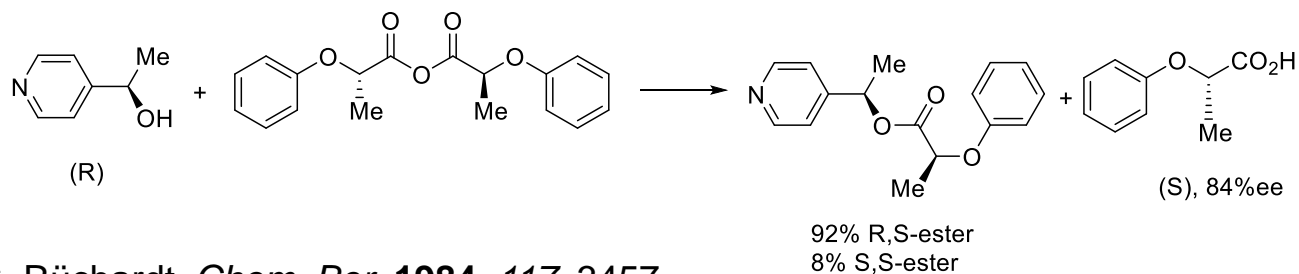

U. Salz, C. Rüchardt, *Chem. Ber.* **1984**, 117, 3457.

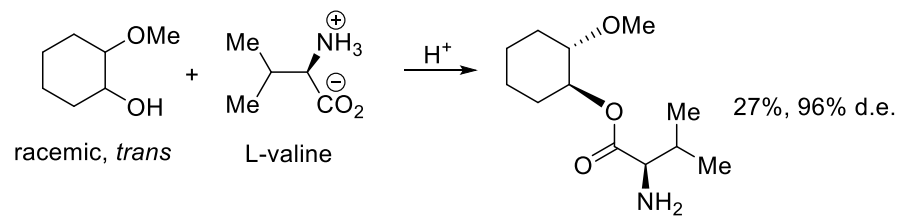

P. Stead, H. Marley, M. Mahmoudoan, G. Webb, D. Noble, Y. T. Ip, E. Piga, S. Roberts, M. J. Dawson, *Tetrahedron: Asymmetry* **1996**, 7, 2247.

Determination of the enantiomeric purity by NMR methods

Use of chiral shifts reagents:

C. C. Hinckley, *J. Am. Chem. Soc.* **1969**, *91*, 5160.

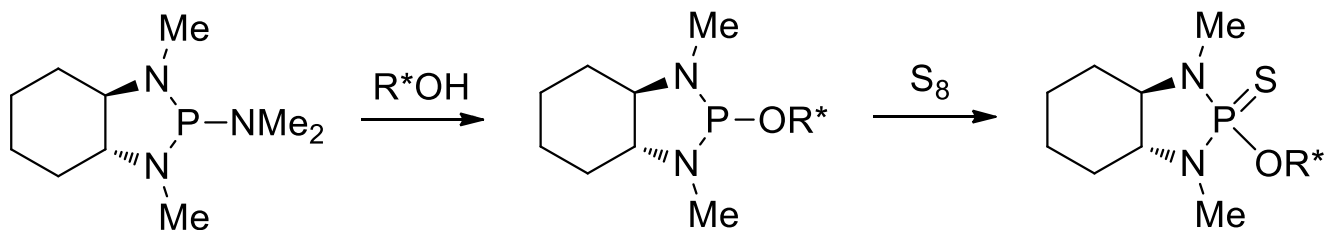
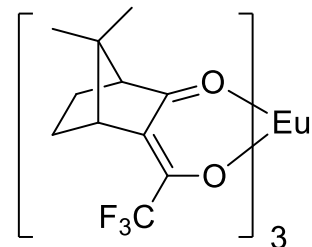

A. Alexakis, J. C. Frutos, S. Mutti, P. Mangeney, *J. Org. Chem.* **1994**, *59*, 3326.

Determination of ee% by NMR Methods: review article D. Parker *Chem. Rev.* **1991**, *91*, 1441

Determination of the absolute configuration

Classical X-ray analysis does not allow to distinguish between two enantiomeric structures.

The method of Bijvoet (1951) uses heavy metal salts and allows the determination of the absolute configuration of molecules.

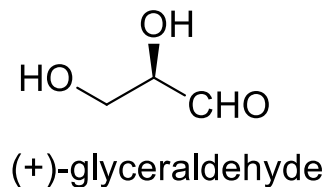
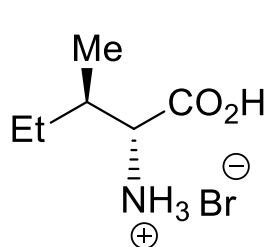
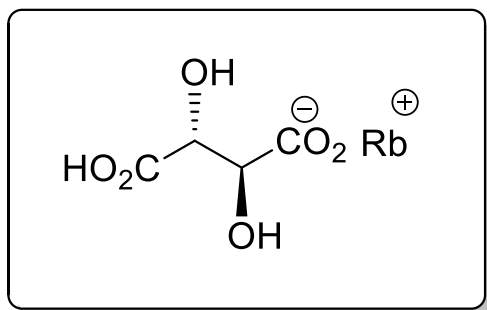

* The absolute configuration of (+)-glyceraldehyde was correct

J. M. Bijvoet, A. F. Peerdeman, A. J. van Bommel, *Nature*, **1951**, 168, 271.

Chemical correlation (1)

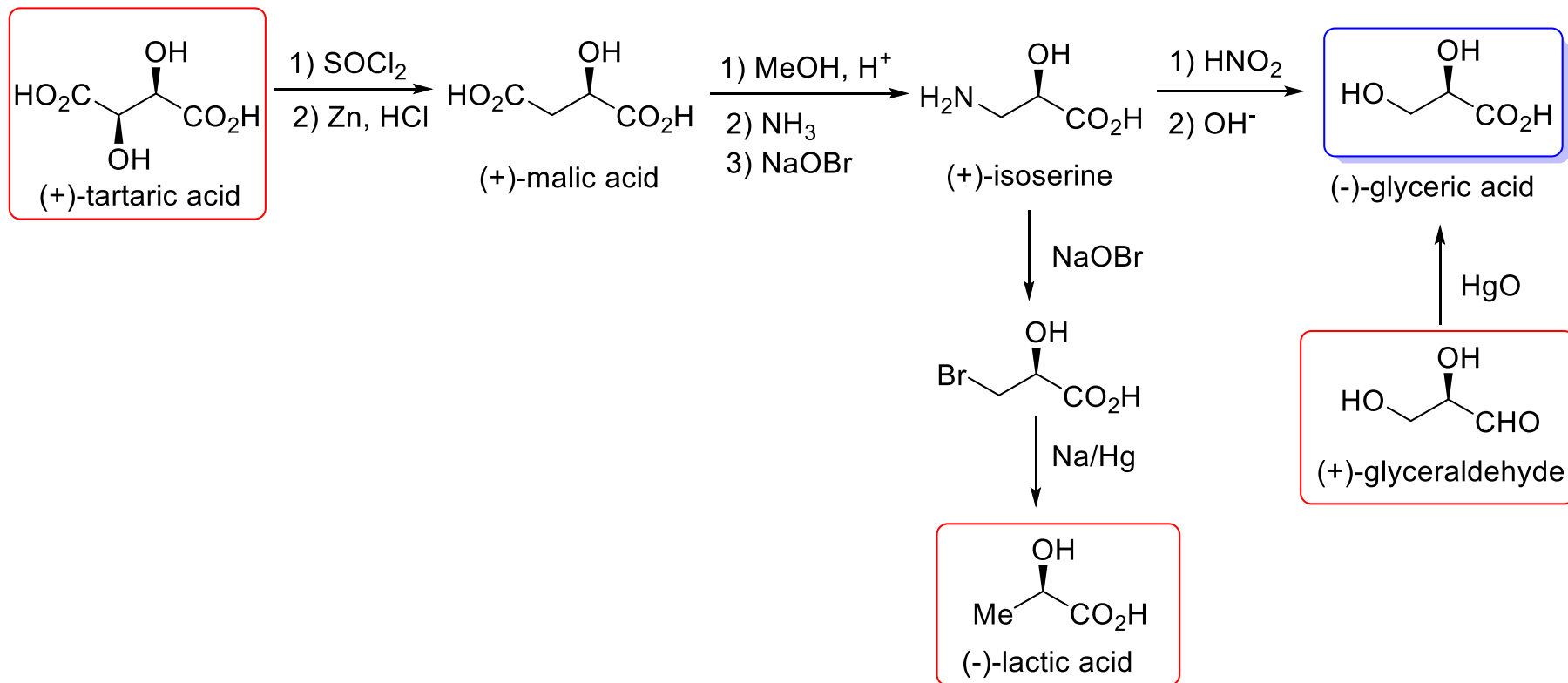

Determination of the relative stereochemistry by NMR methods

Diastereoisomers have different properties: compare with

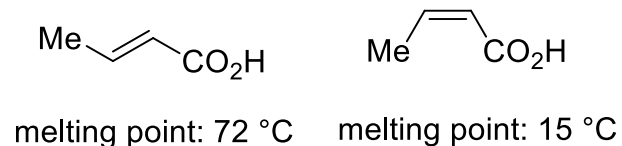

In general - ^1H and ^{13}C NMR analysis allows to differentiate diastereoisomers

Karplus rules

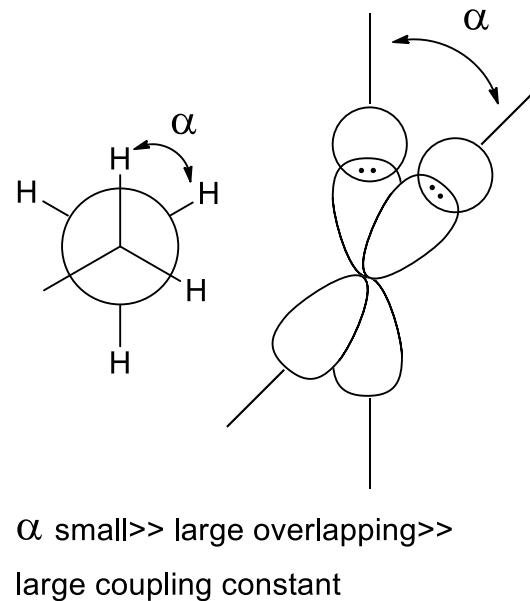
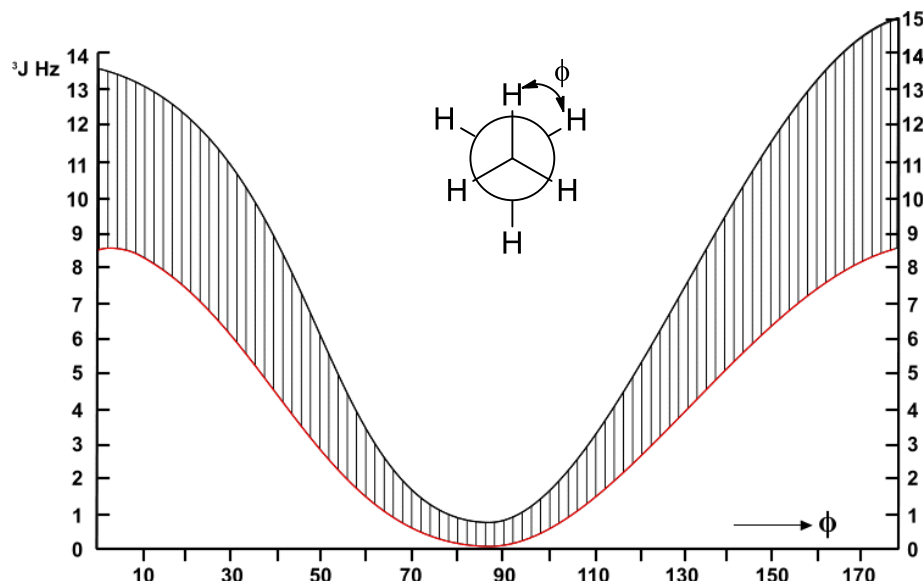

Determination of the relative stereochemistry by NMR methods

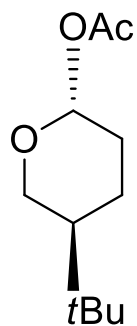

trans

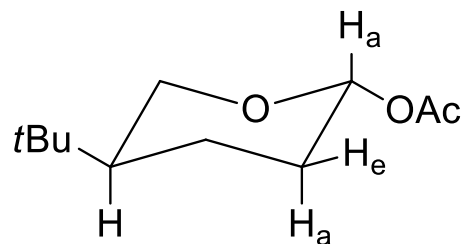

$$J_{aa} = 11 \text{ Hz}$$

$$J_{ae} = 4 \text{ Hz}$$

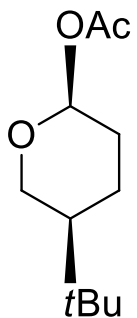
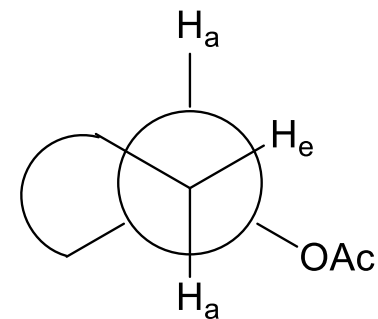

cis

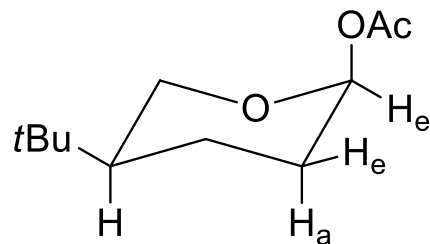

$$J_{ee} = 3 \text{ Hz}$$

$$J_{ea} = 3 \text{ Hz}$$

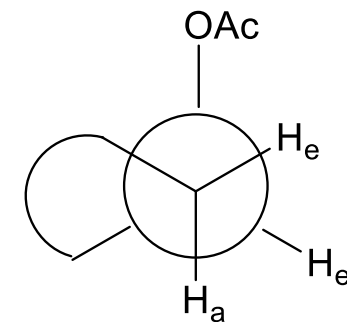

Determination of the configuration of the anomeric center of sugar

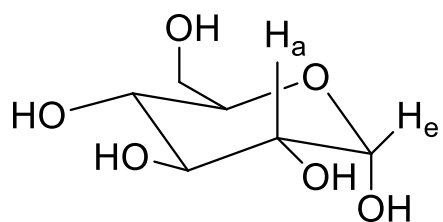

α -form of D-glucose

$$J_{ae} = 3 \text{ Hz}$$

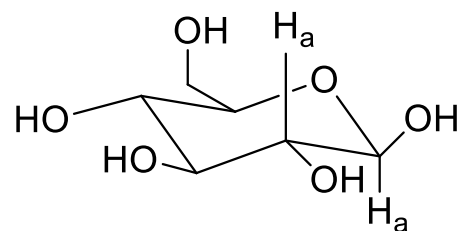

β -form of D-glucose

$$J_{aa} = 7.5 \text{ Hz}$$

Conformational analysis

1943: X-Ray analysis shows a chair conformation for cyclohexane derivatives

1950: Barton shows the difference between axial and equatorial positions in cyclohexane derivatives

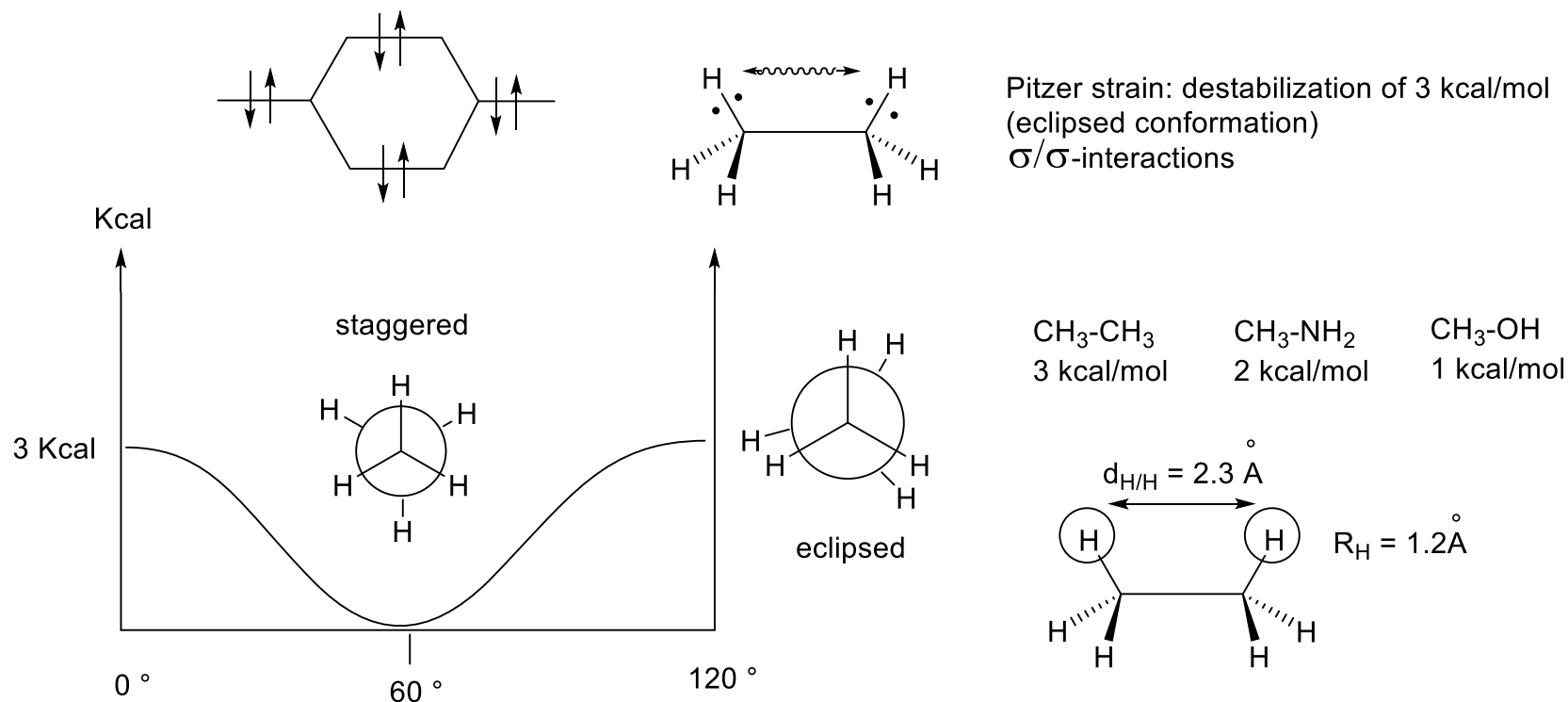

Conformational analysis

$$\Delta G^\circ = -3.0 \text{ Kcal} \implies K = e^{\frac{-\Delta G^\circ}{RT}} = \text{ca. } 100$$

\implies 99% of ethane molecules exist in a staggered conformation

Isomeric ratios at equilibrium (T = 25 °C)

percent of more stable isomer	K	$\Delta G^\circ_{25^\circ\text{C}}$ (Kcal/mol)
50	1.0	0.0
55	1.22	0.12
60	1.50	0.24
70	2.33	0.50
75	3.0	0.65
85	5.67	1.03
90	9.0	1.30
95	19.0	1.75
99	99.0	2.72
99.9	999.0	4.09

Conformational analysis

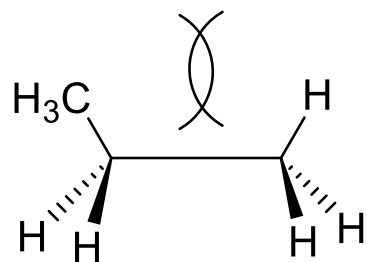

4 kcal/mol

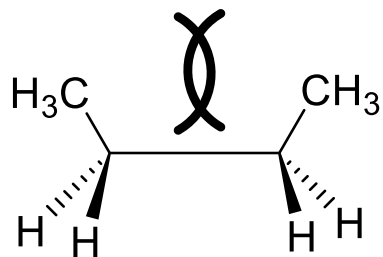

Pitzer strain

van der Waals interactions

6 kcal/mol = ca. 3 kcal/mol + 3 kcal/mol

Conformational analysis of butane

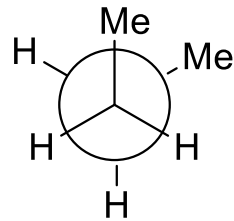
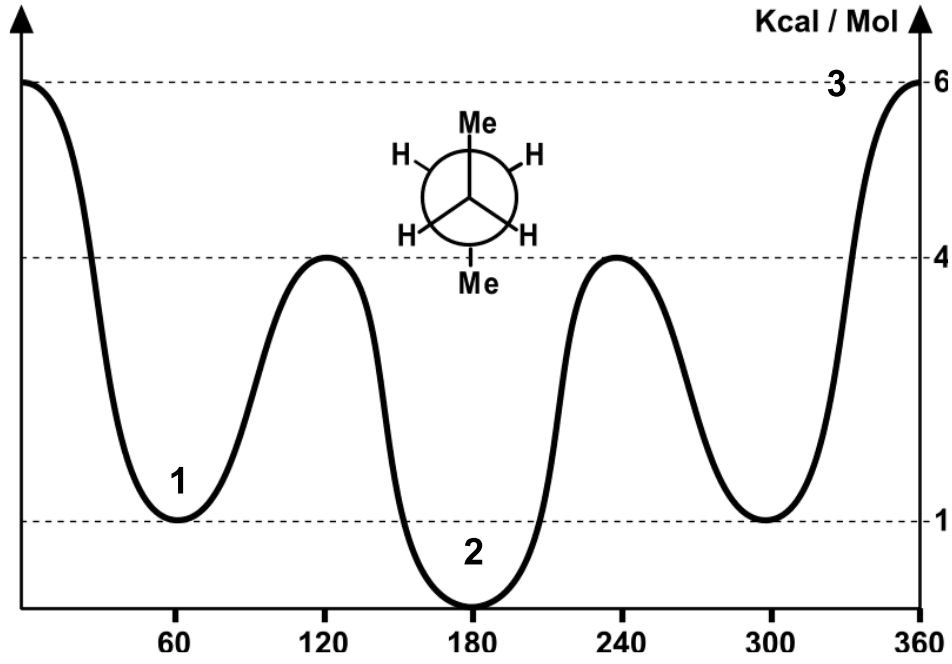

1: gauche

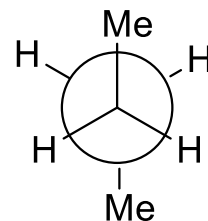

2: antiperiplanar

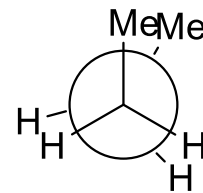

3: synperiplanar

70:30 mixture of antiperiplanar and gauche conformations

Conformational analysis

Rotational barriers of compounds of type CH₃-X

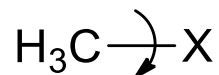

Alkanes	Barrier (kcal/mol)	Heteroatom compounds	Barrier (kcal/mol)
CH ₃ -CH ₃	2.9	CH ₃ -NH ₂	2.0
CH ₃ -CH ₂ CH ₃	3.4	CH ₃ -NHCH ₃	3.0
CH ₃ -CH(CH ₃) ₂	3.9	CH ₃ -N(CH ₃) ₂	4.4
CH ₃ -C(CH ₃) ₃	4.7	CH ₃ -OH	1.1
(CH ₃) ₃ C-C(CH ₃) ₃	8.4	CH ₃ -OCH ₃	4.6

J. P. Lowe, *Prog. Phys. Org. Chem.* **1968**, 6, 1.

Conformational analysis of bonding between Csp^2 and Csp^3

Propene: 2.7 kcal/mol stabilization effects of the Me-group ($n \rightarrow \pi^*$)

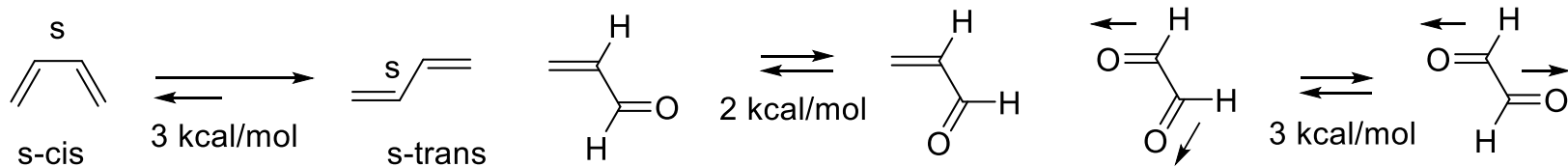
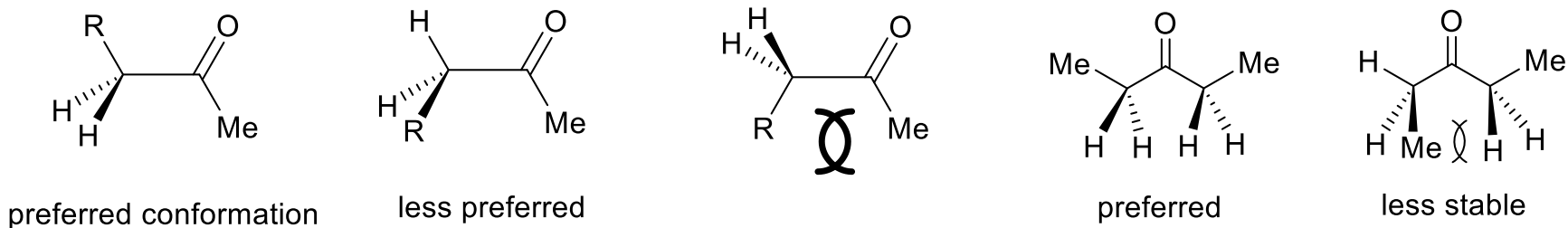
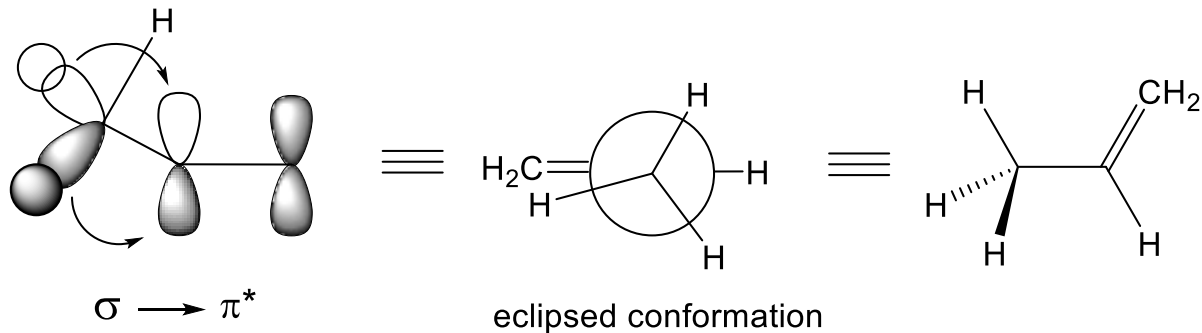

1,3-Diaxial strain

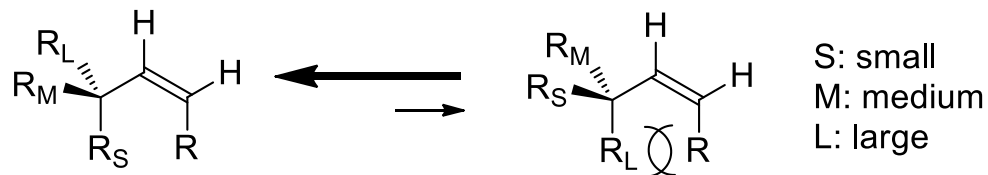
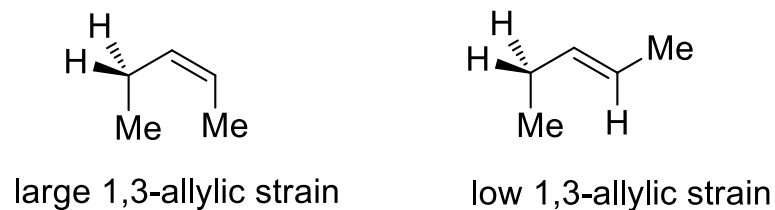
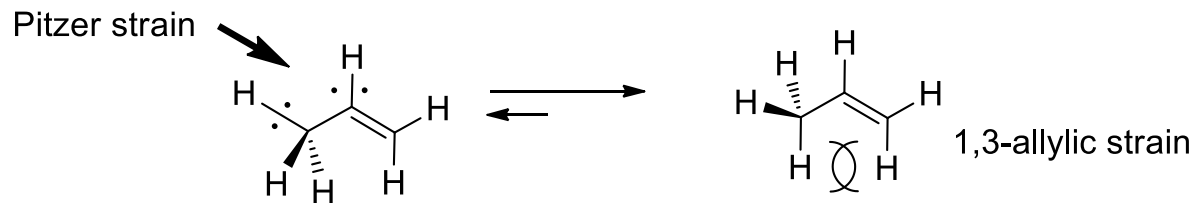

R. W. Hoffmann, *Chem. Rev.* **1989**, 89, 1841

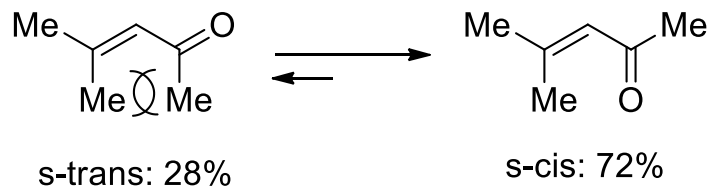

A. Bienvenue, *J. Am. Chem. Soc.* **1973**, 95, 7345

1,3-Diaxial strain

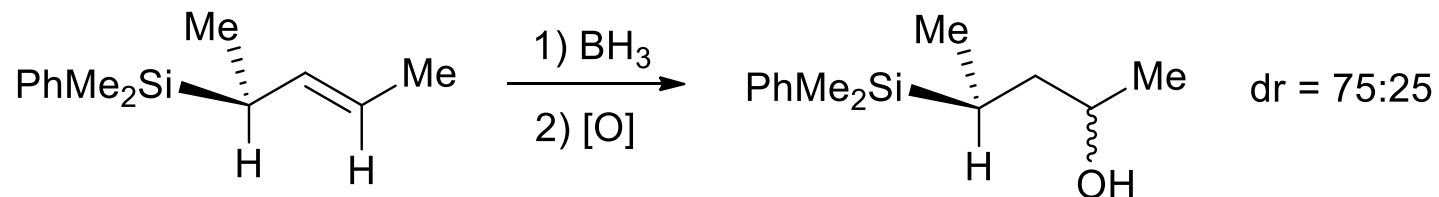

but

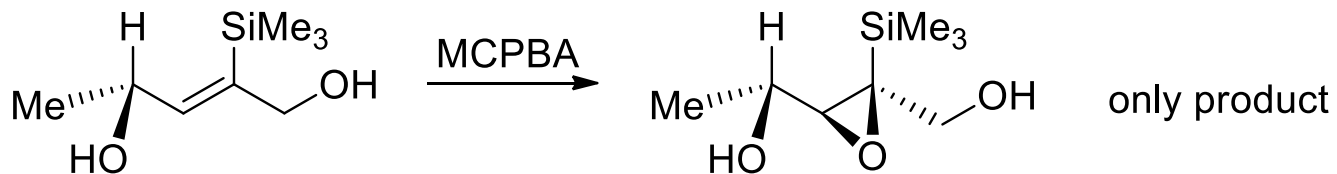
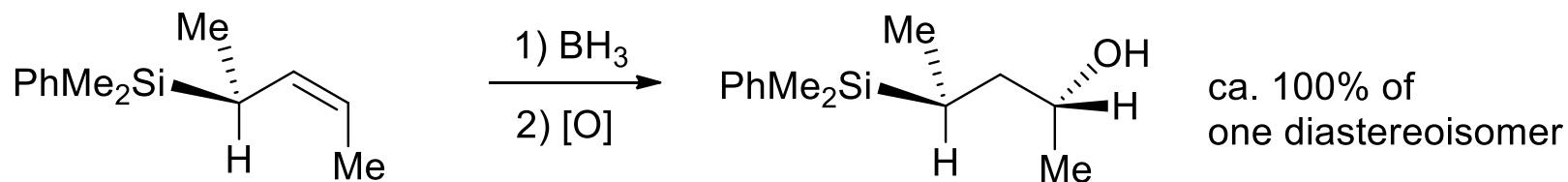

Conformational analysis of cyclic systems: Bayer strain

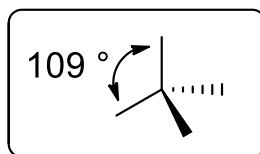

ideal tetrahedral angle

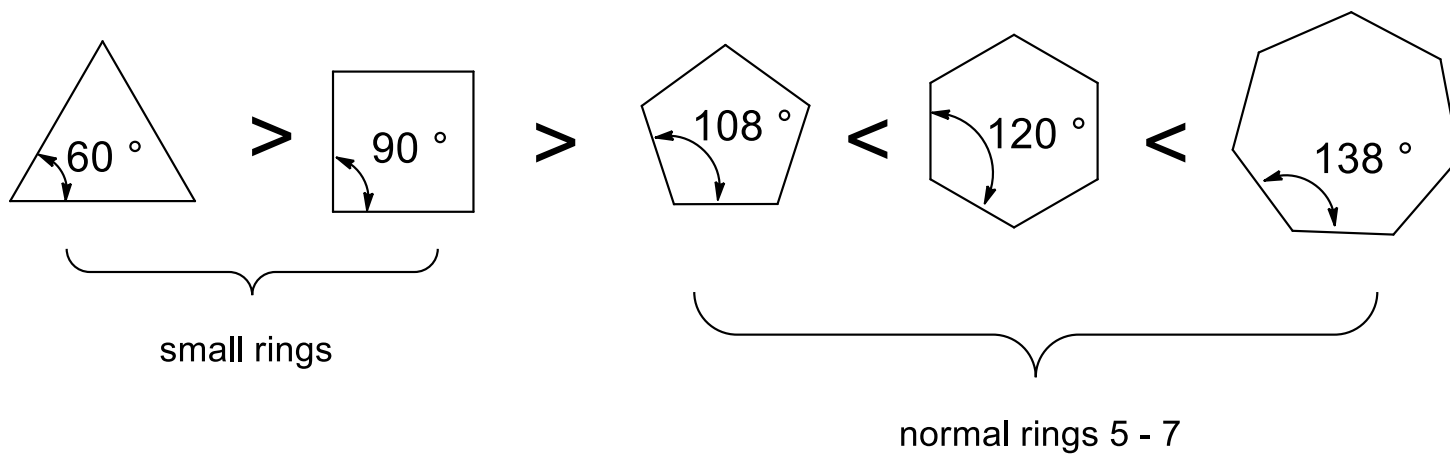

Classification of cyclic organic molecules

Cyclic molecules can be classified in 4 categories:

small rings: 3-4;

normal rings: 5-7;

medium-sized rings: 8 -12;

large rings: 13-membered rings and larger

	ring size	strain energy per methylene group	
small rings	{ 3 4	9	
		6.8	
normal rings	{ 5 6 7	1.4	
		0.2	
		1.1	
medium-sized rings	{ 8 9 10 11 12	1.4	} transannular interaction
		1.6	
		1.	
		1.3	
		0.5	

large rings behave like a per-chain systems

The cyclopropane ring

planar ring system: Pitzer strain 6 Kcal/mol

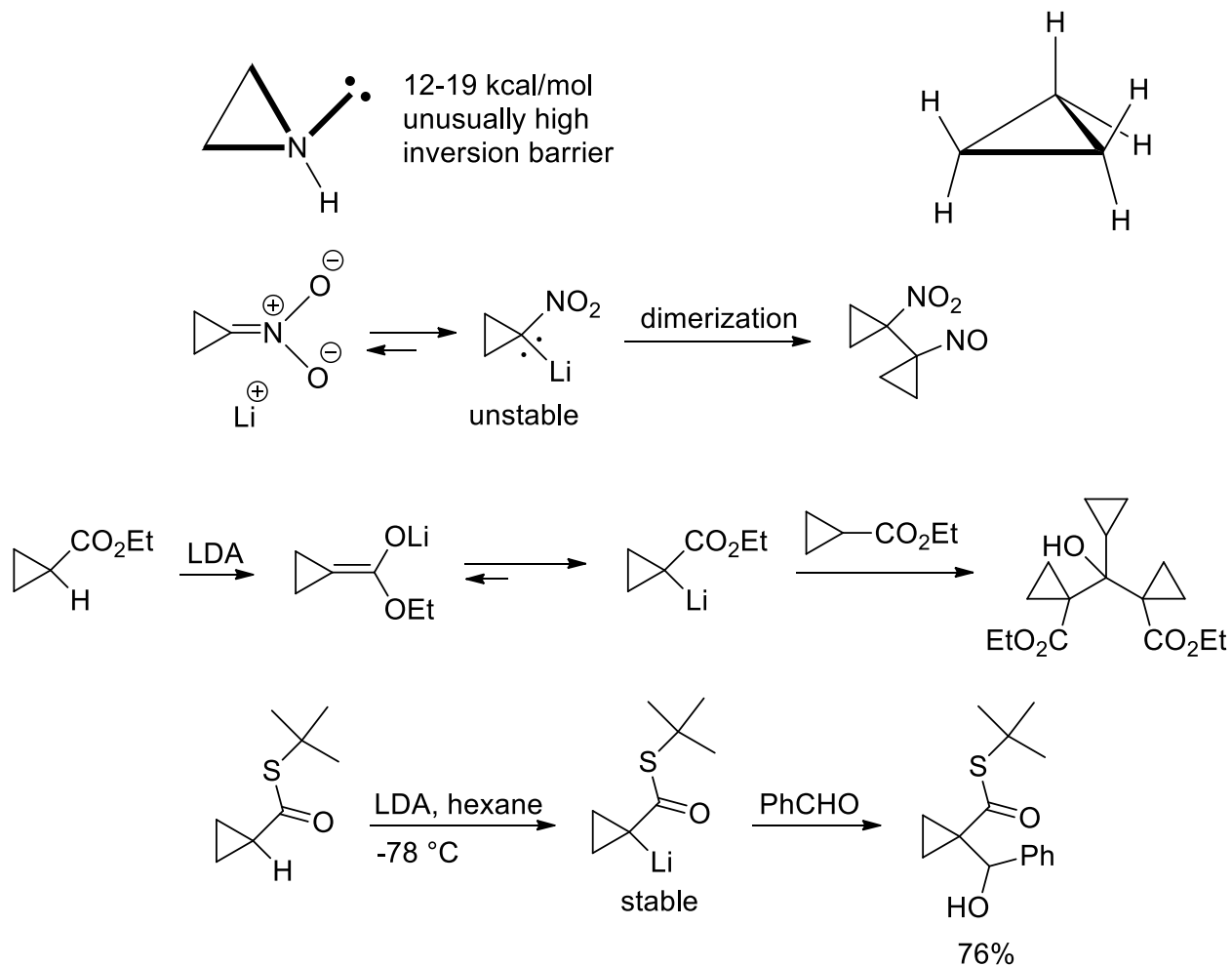

Conformation of the cyclopropylmethyl cation

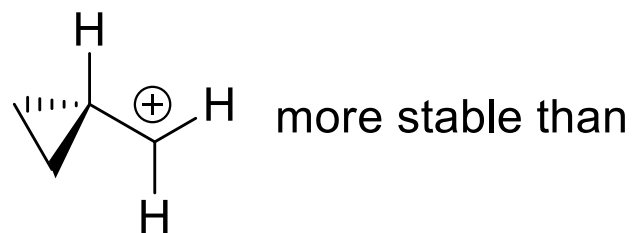

eclipsed
conformation

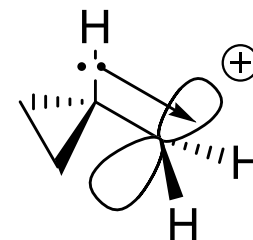

staggered
conformation

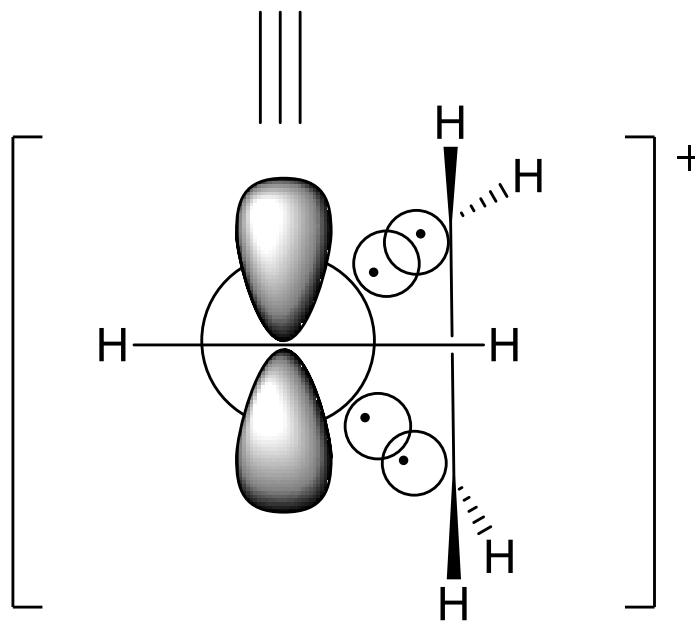

Synthesis of cyclopropanes

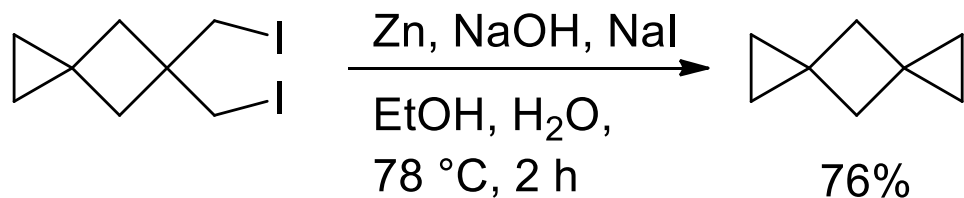

H.-D. Beckhaus, C. Rüchardt, S. I. Kozhushkov, V. N. Belov, S. P. Verevkin, A. de Meijere, *J. Am. Chem. Soc.* **1995**, *117*, 11854.

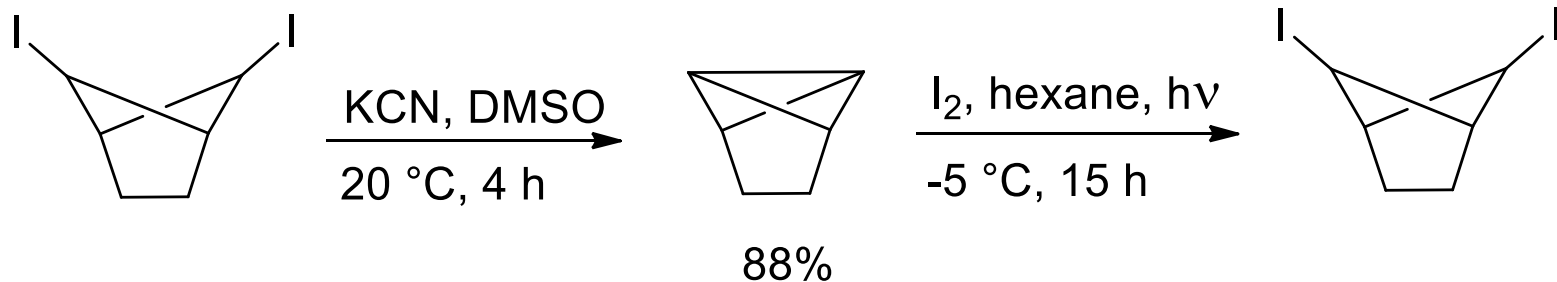

C. Mazal, O. Skarka, J. Kaleta, J. Michl, *Org. Lett.* **2006**, *8*, 749.

Synthesis of cyclopropanes

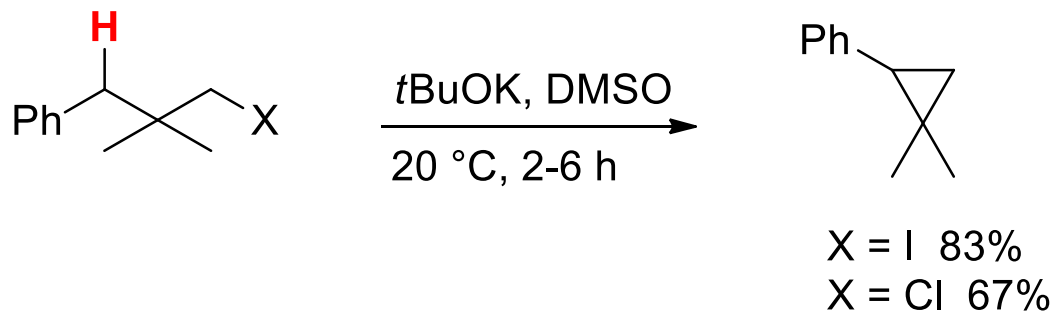

J. E. Argüello, A. B. Peñeñory, R. A. Rossi, *J. Org. Chem.* **1999**, 64, 6115.

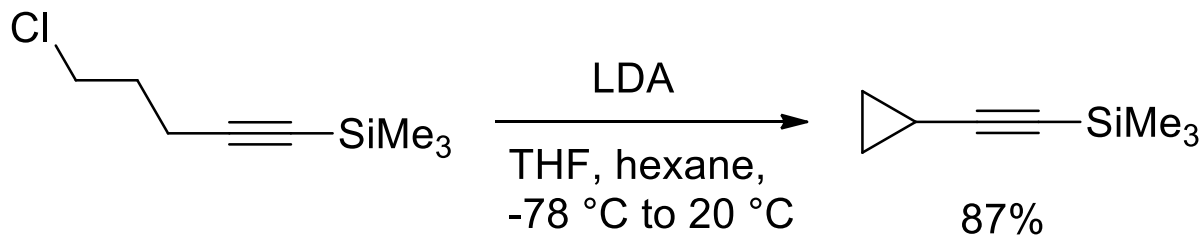

H.-C. Militzer, S. Schömenauer, C. Otte, C. Puls, J. Hain, S. Bräse, A. de Meijere, *Synthesis* **1993**, 998.

The cyclobutane and cyclopentane systems

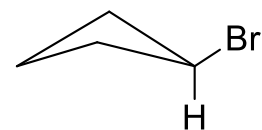
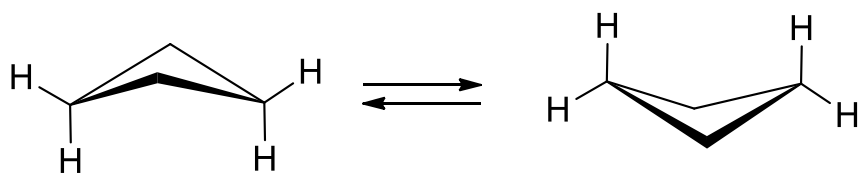

1.5 kcal/mol inversion barrier

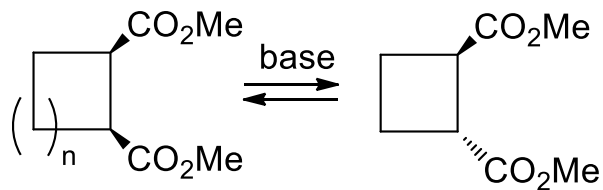

$n = 1$ 90:10

$n = 3$ 97(trans):3(cis)

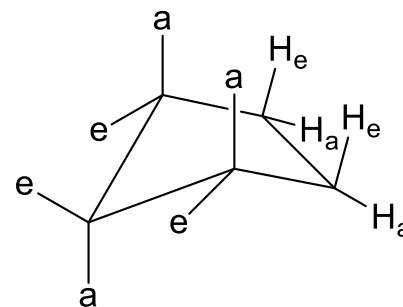

pseudo-axial

The conformations of cyclohexane

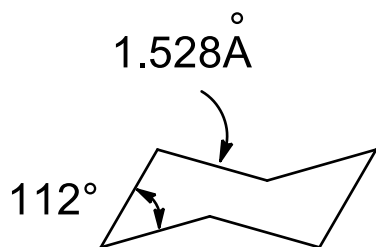

Chair form
0 kcal/mol

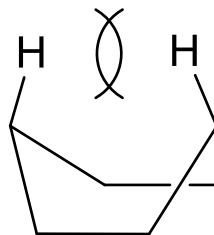

Boat form
7.1 kcal/mol

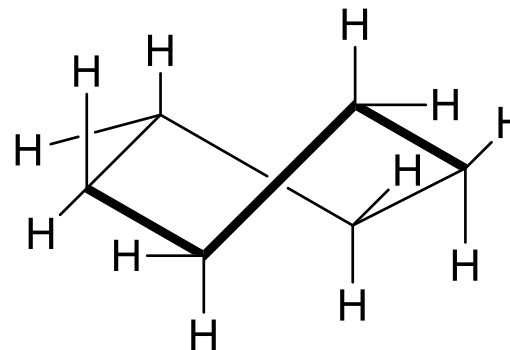

5.5 kcal/mol

inversion barrier of cyclohexane
ca. 10 kcal/mol



100 000 inversions/s
at 25 °C

Energy diagram for ring inversion of cyclohexane

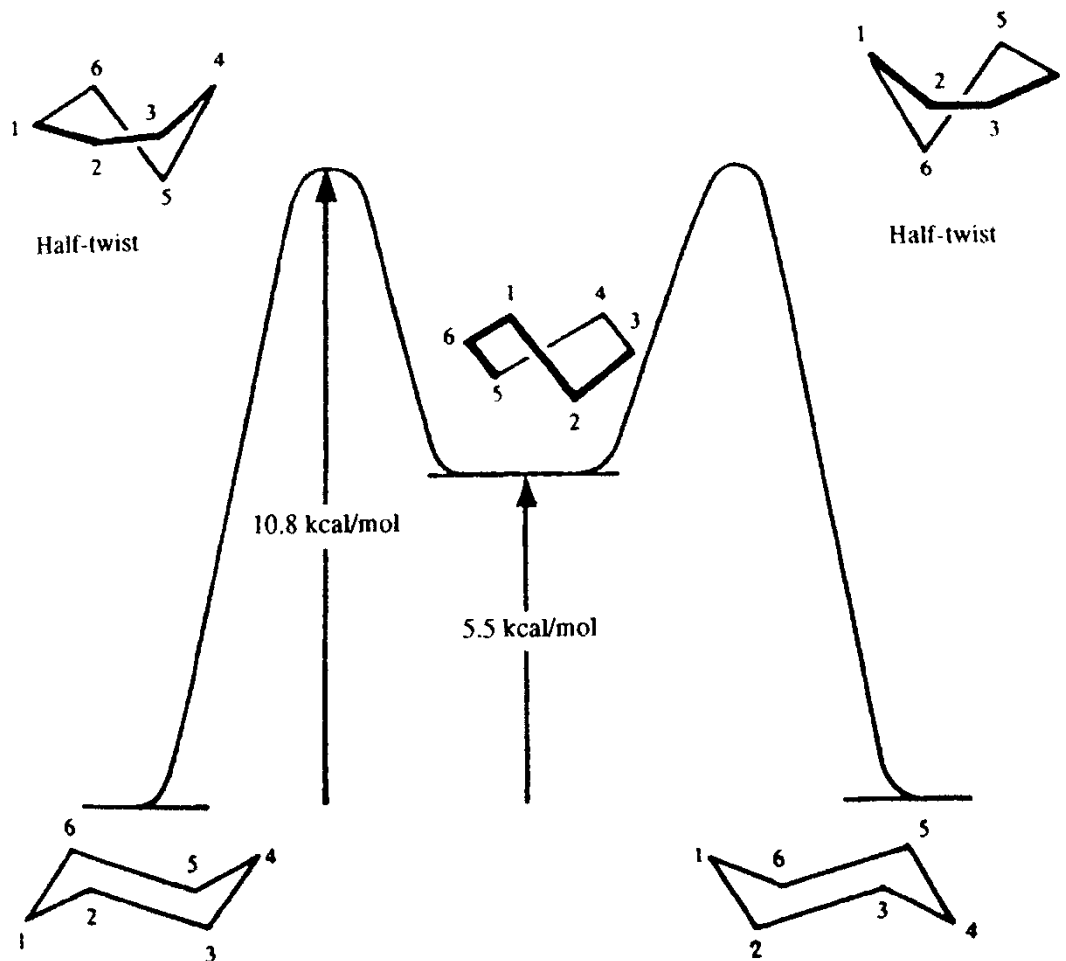

N. Leventis, S. B. Hanna, C. Sotiriou-Leventis, *J. Chem. Educ.* **1997**, *74*, 813.

The conformation of substituted cyclohexane

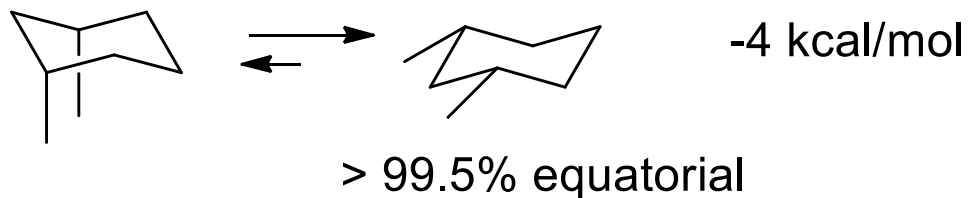
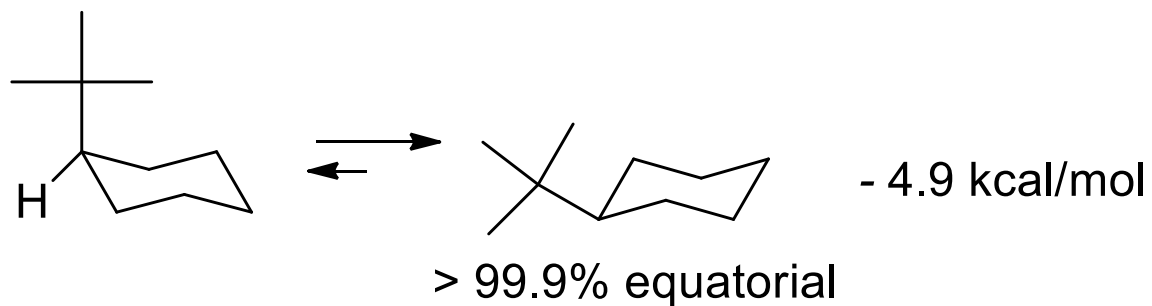
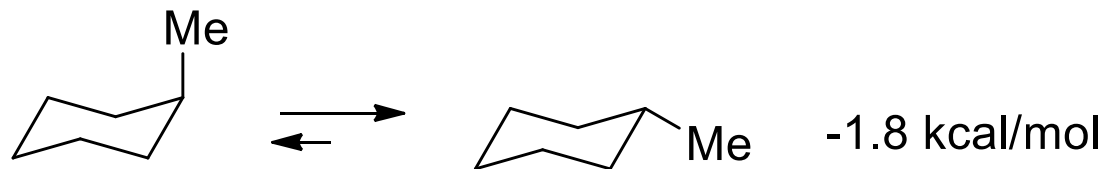

For substituted cyclohexanes, a slow exchange is observed below $-50 \text{ }^\circ\text{C}$

Inversion of cyclohexane

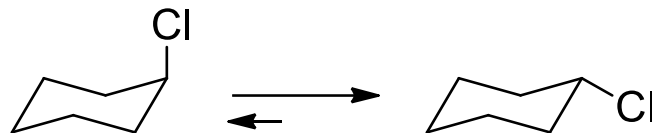

Half-life for conformation inversion of cyclohexane at various temperatures

T (°C)	Half-life
25	1.3×10^{-5} s
-60	0.03 s
-120	23 min
-160	22 years !

A crystallization of the equatorial isomer at -150 °C is possible

F. R. Jensen, *J. Am. Chem. Soc.* **1969**, 91, 3223.

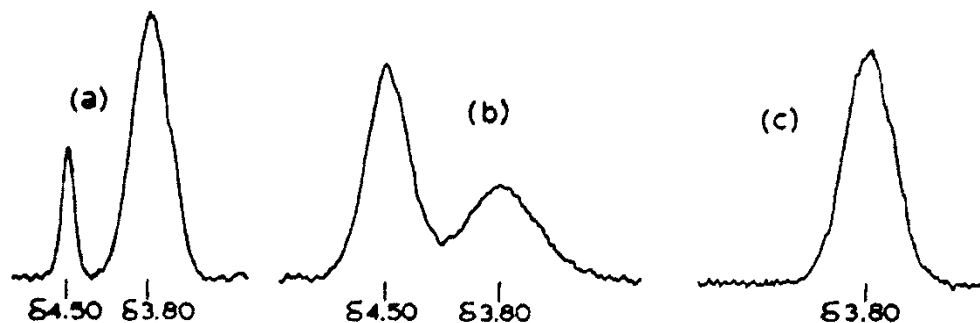

60-MHz ^1H -NMR spectrum for the C(1)H in chlorocyclohexane. a) axial-equatorial equilibrium at -115 °C, b) axial enriched mixture at -150 °C, c) pure equatorial conformer at -150 °C

Cyclohexyl iodide

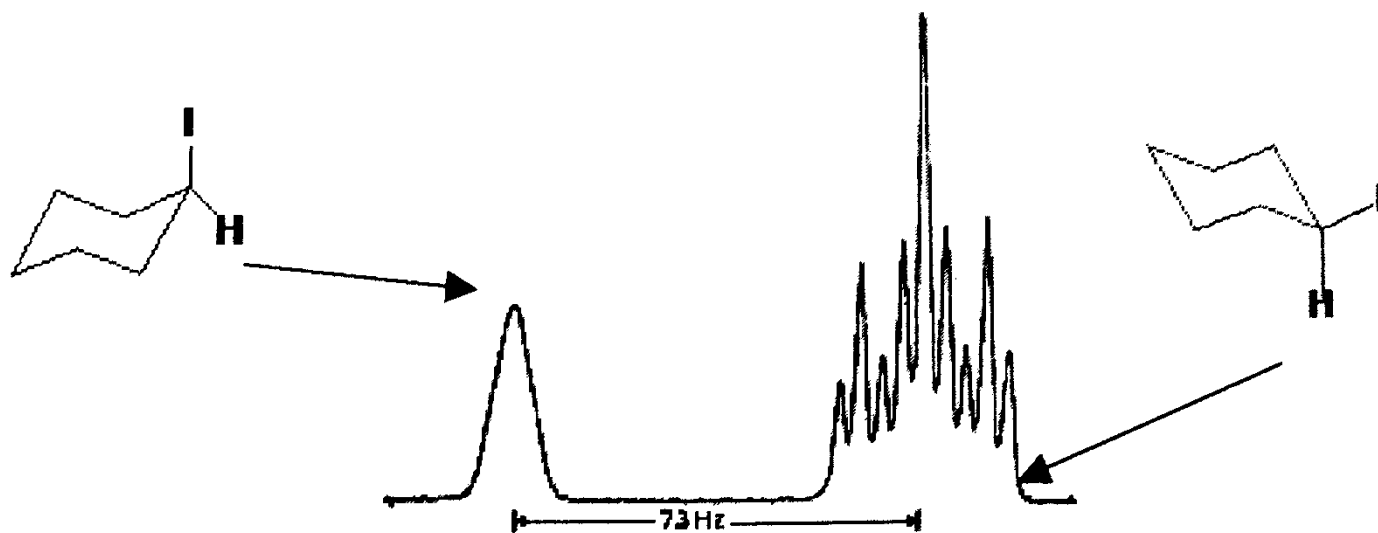
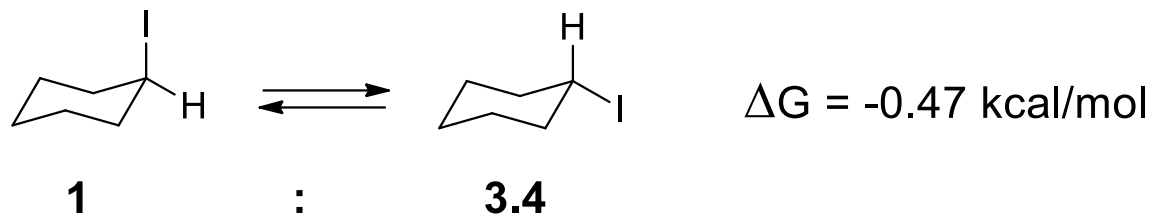

100 MHz ^1H -NMR spectrum of iodocyclohexane at -80 °C. Only the low field C(1)H signal is shown.

F. R. Jensen, *J. Am. Chem. Soc.* **1969**, *91*, 344.

Temperature depending NMR-spectra / exchange rate of protons

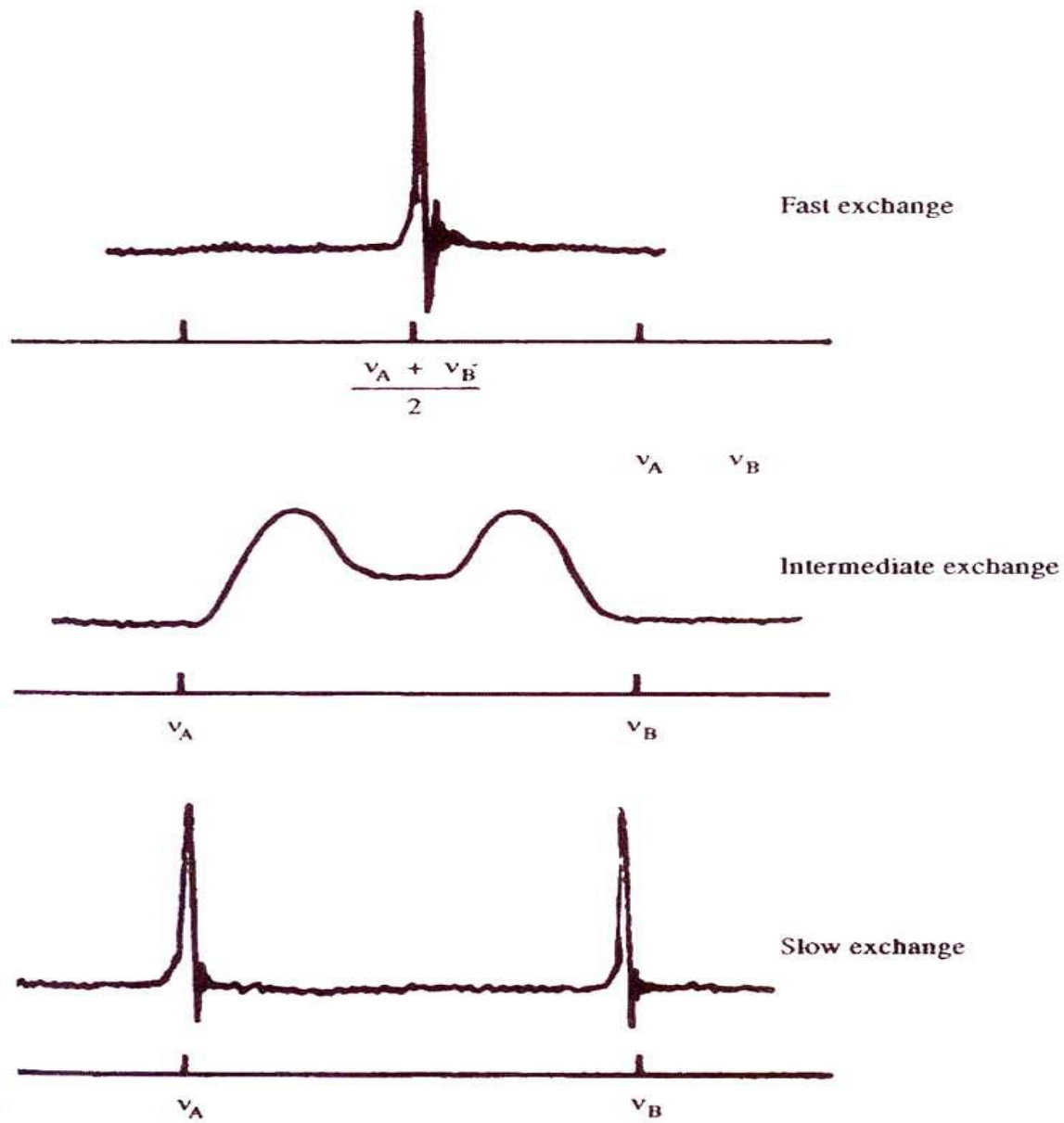

Conformational free energies ($-\Delta G$) for some substituents

Substituent	$-\Delta G_c$	Substituent	$-\Delta G_c$
F	0.26	C ₆ H ₅	2.9
Cl	0.53	CN	0.2
I	0.47	CH ₃ CO ₂	0.71
CH ₃	1.8	HO ₂ C	1.35
CH ₃ CH ₂	1.8	C ₂ H ₅ O ₂ C	1.1-1.2
(CH ₃) ₂ CH	2.1	HO (aprotic solvent)	0.52
(CH ₃) ₃ C	>4.7	HO (protic solvent)	0.87
CH ₂ =CH	1.7	CH ₃ O	0.60
HC≡C	0.5	O ₂ N	1.16

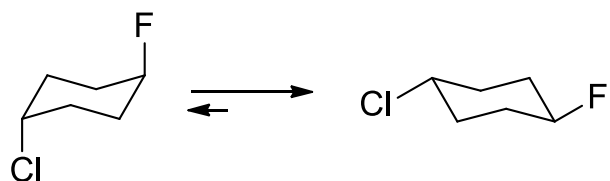

$$\Delta G = -(0.26 + 0.53) = -0.79 \text{ kcal/mol}$$

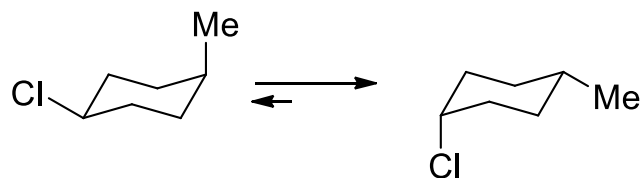

$$\Delta G = -(1.8 - 0.53) = -1.27 \text{ kcal/mol}$$

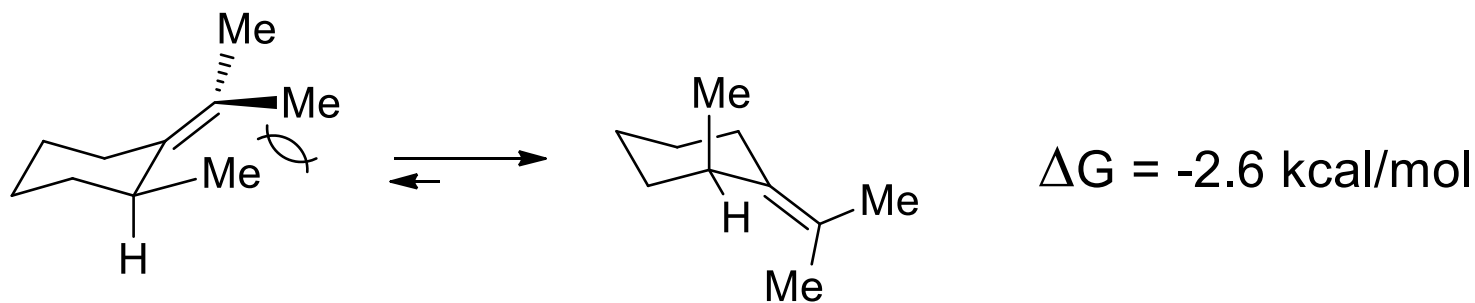

F. Johnson, *Chem. Rev.* **1968**, 68, 375

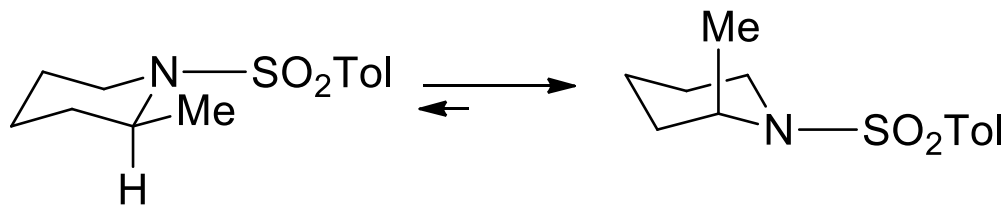

S. Seel, T. Thaler, K. Takatsu, C. Zhang, H. Zipse, B. F. Straub, P. Mayer, P. Knochel, *J. Am. Chem. Soc.*, **2011**, 133, 4774.

Stereoselective effects: Curtin-Hammett principle

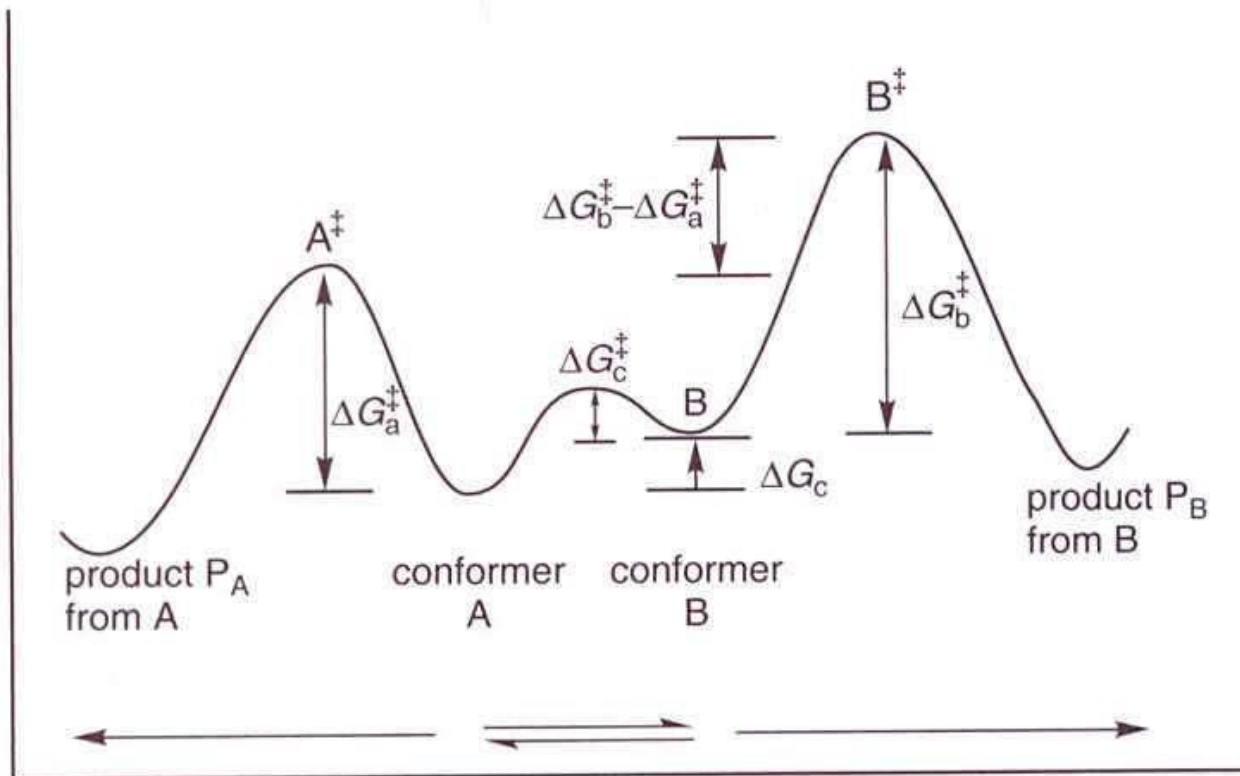
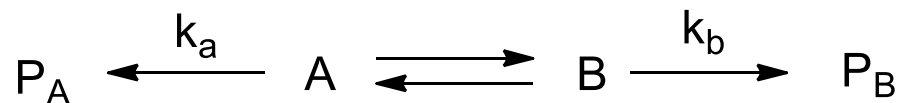

According to the Curtin-Hammett principle, the position of the equilibrium between two molecules **A** and **B** cannot be used to predict the ratio between the products **P_A** and **P_B**, only the difference between the activation energies $\Delta G_B^\ddagger - \Delta G_A^\ddagger$ is relevant

The Curtin-Hammett principle

Stereoselective E₂-elimination

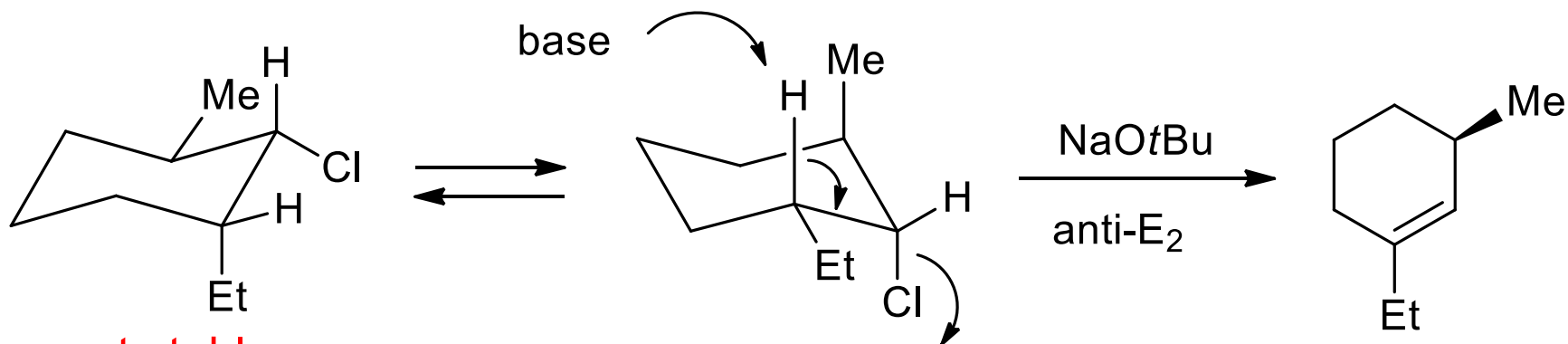

most stable
conformer but
unreactive for
an E₂-elimination

most reactive
conformer
(antiperiplanar arrangement
of the C-H and C-Cl bond)

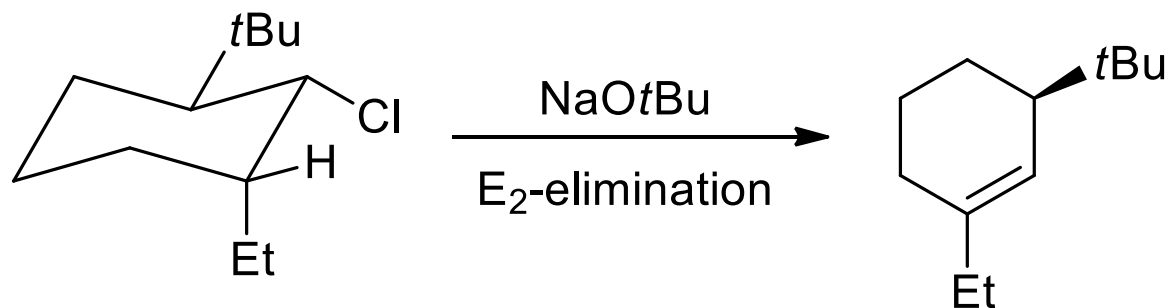

Example of the Curtin-Hammett principle

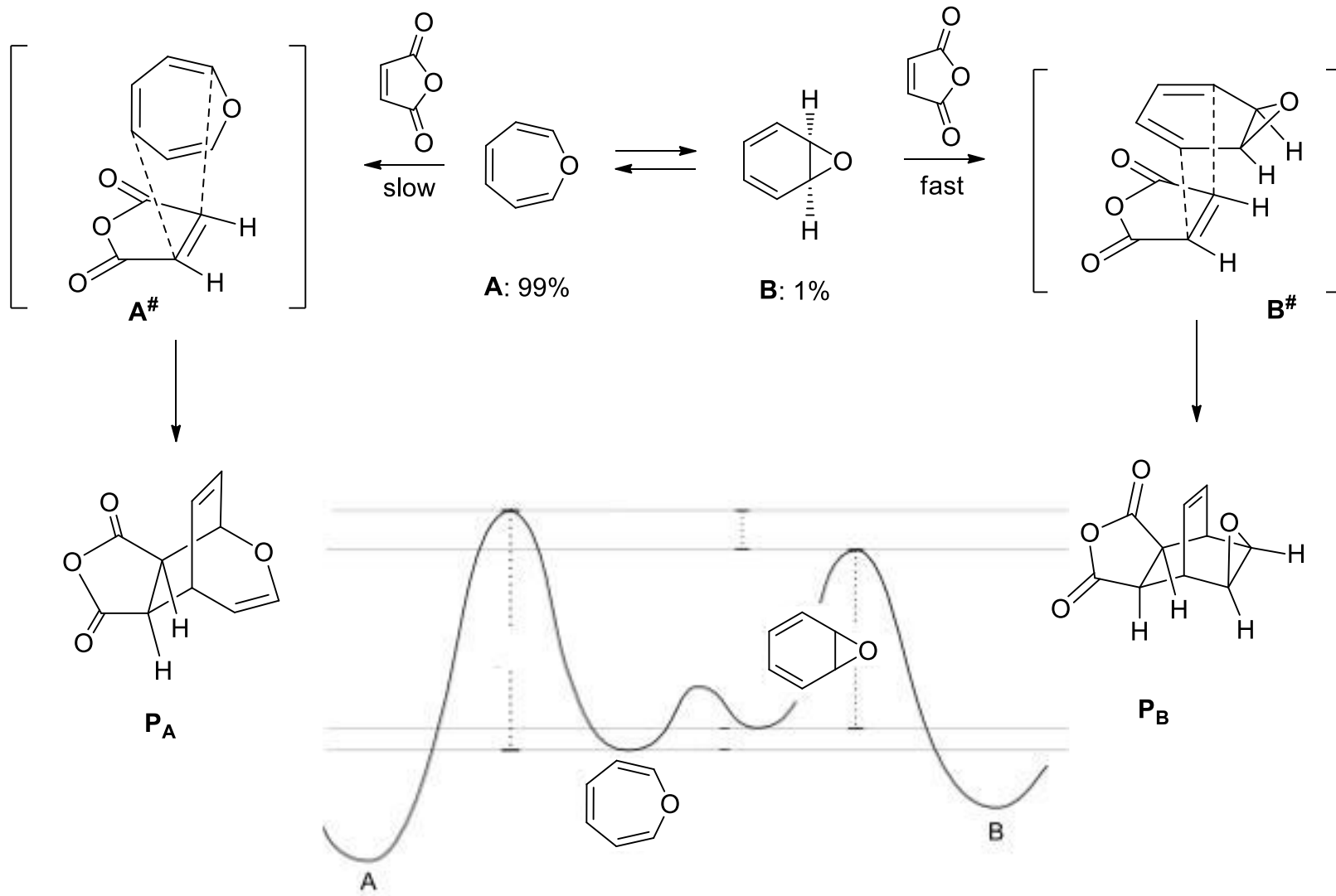

The Curtin-Hammett principle

According to the Curtin-Hammett principle, the position of the equilibrium between two molecules A and B cannot be used to predict the ratio between the products.

Exception: when the activation energy are very similar

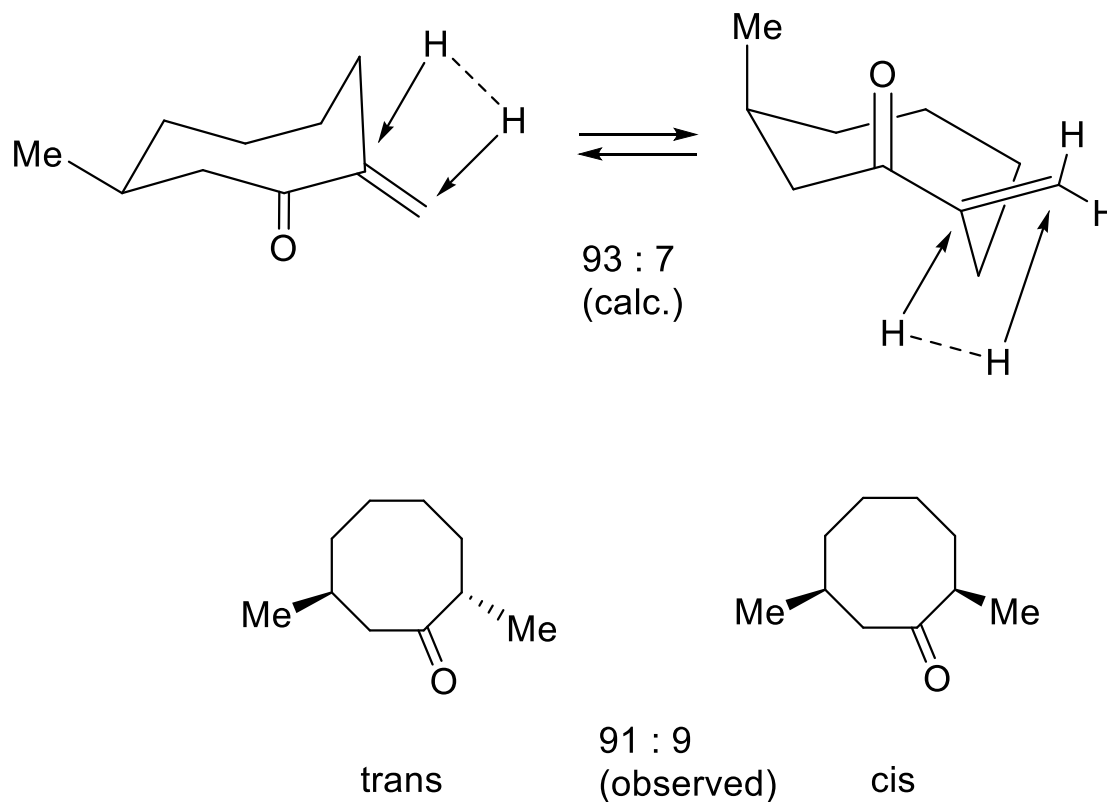

The anomeric effect

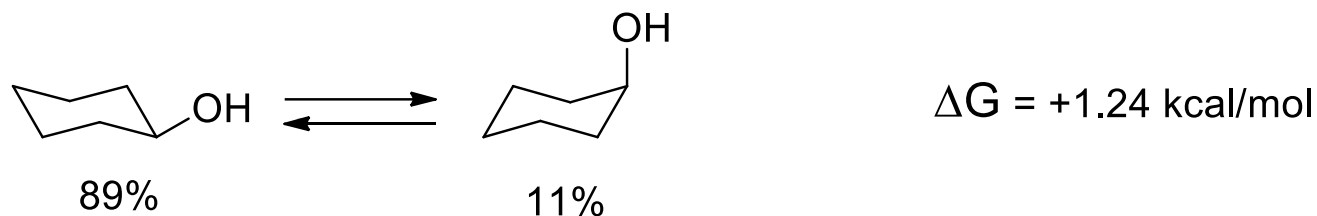
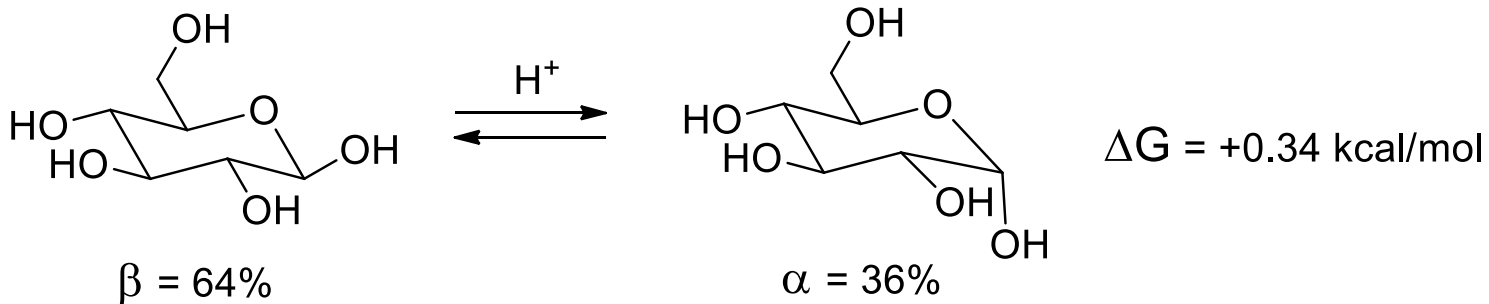

Anomeric effect: 0.9 kcal/mol

The tendency to prefer a substituent in an axial position increases with the electronegativity of the substituents. X = OAc, Cl, F,...

E. Juaristi, *Tetrahedron*, **1992**, 48, 5019

Origin of the anomeric effect

Most probable origin: hyperconjugation effect between electron lone pair of oxygen and the σ^* (C-X) bond

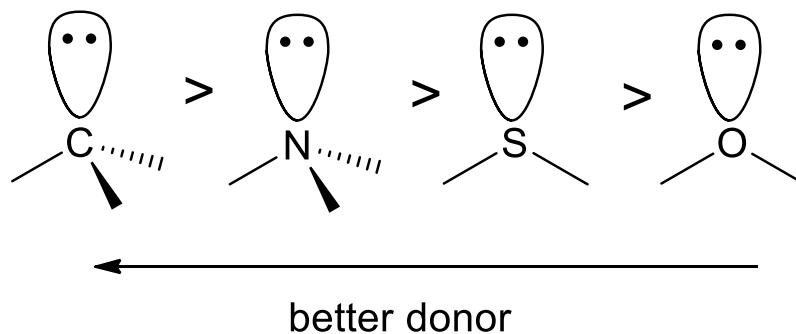
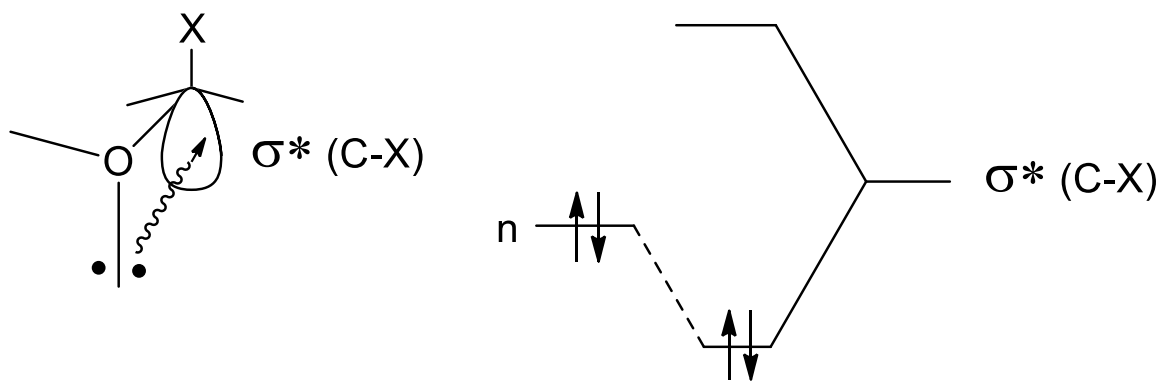

The anomeric effect

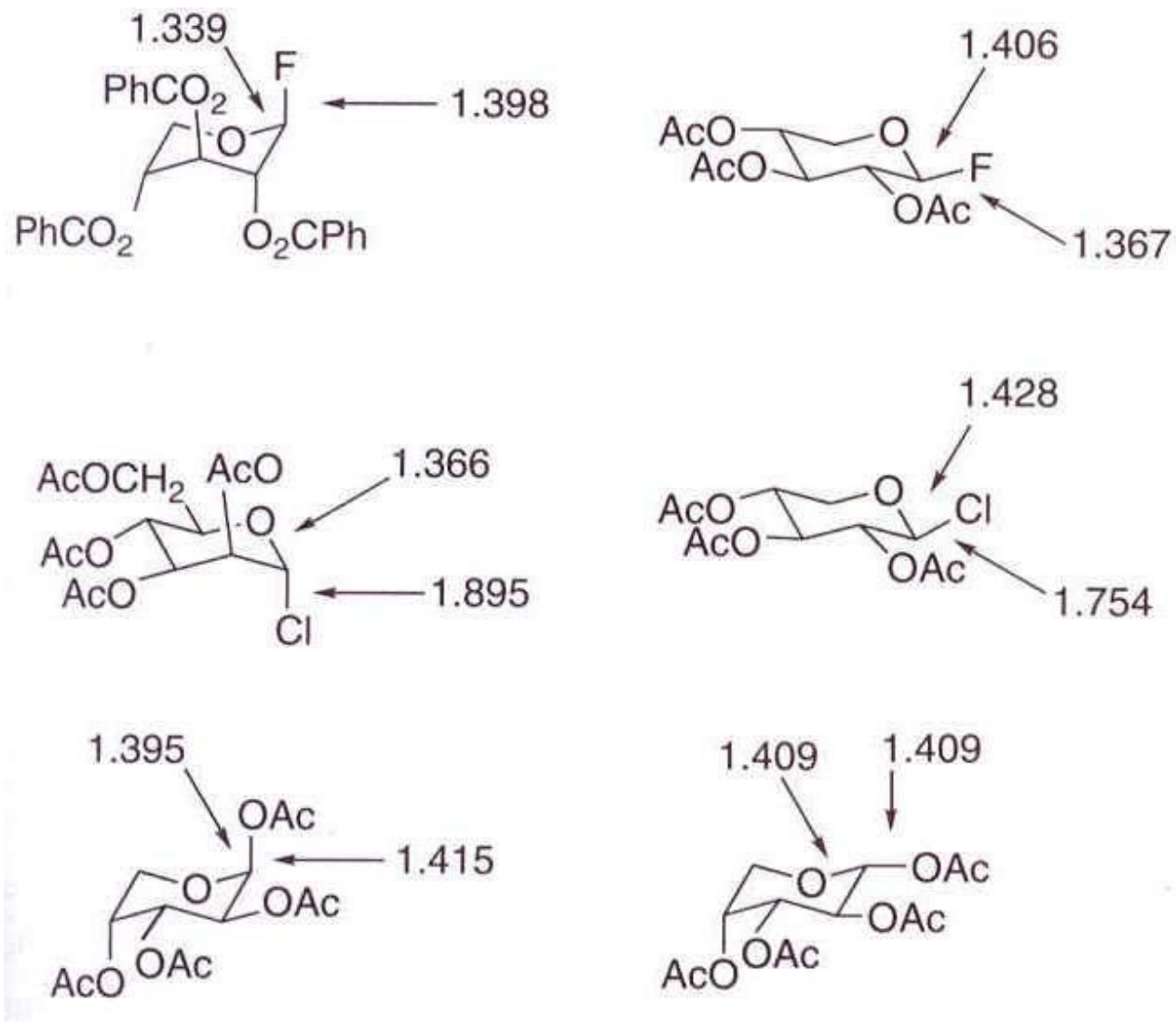

The anomeric effect

Application: Determination of the conformation of a ketal

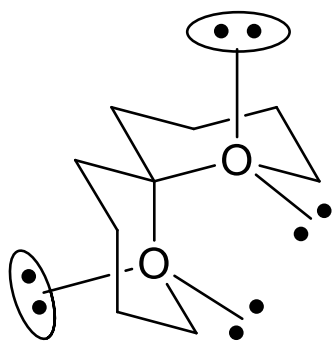
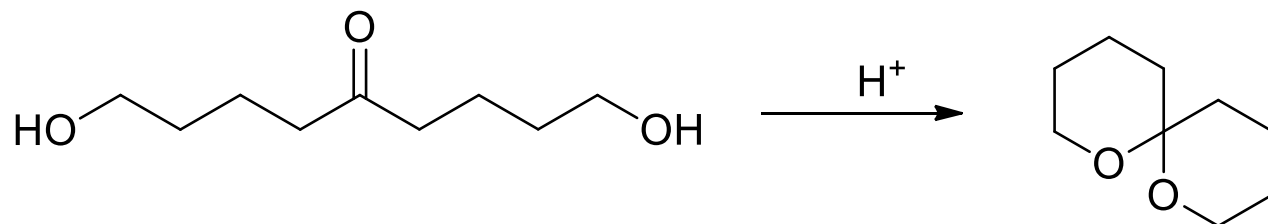

2 anomeric effects

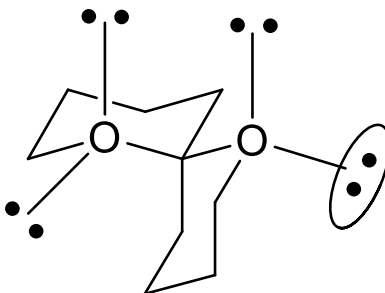

1 anomeric effect

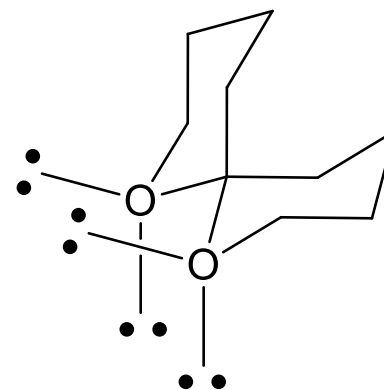

0 anomeric effect

The anomeric effect

The anomeric effect allows to predict the preferred conformation of organic molecules:

Preferred conformation for

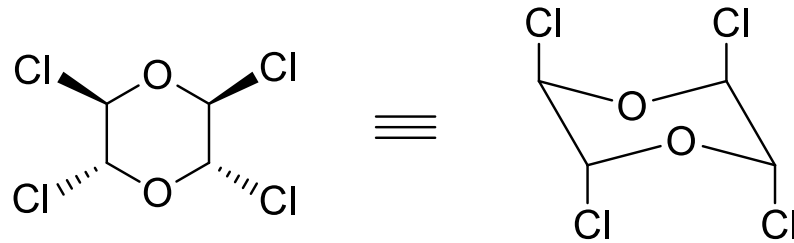

Preferred conformation of esters :

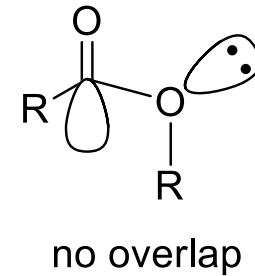
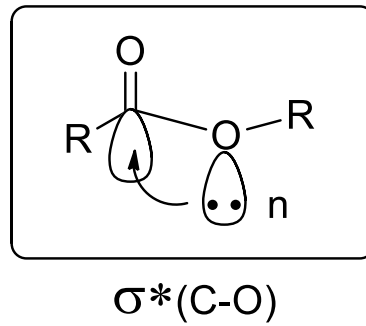

The kinetic anomeric effect

Kinetic effects:

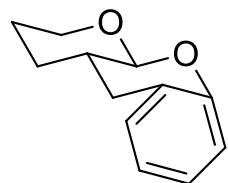
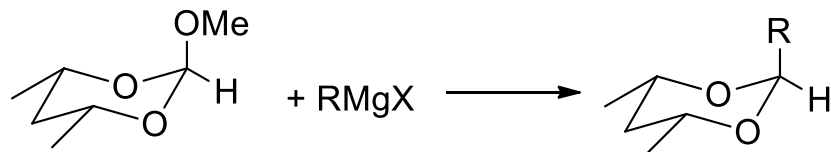

is hydrolyzed 3000 times slower than

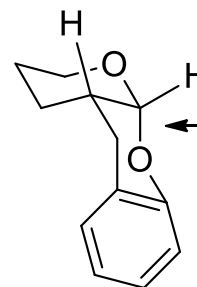

← better leaving group

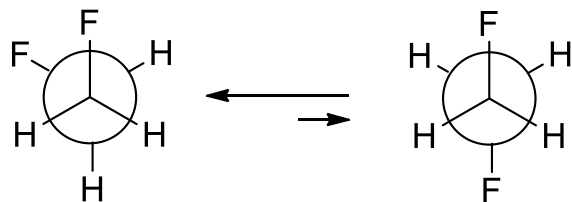

preferred gauche conformation

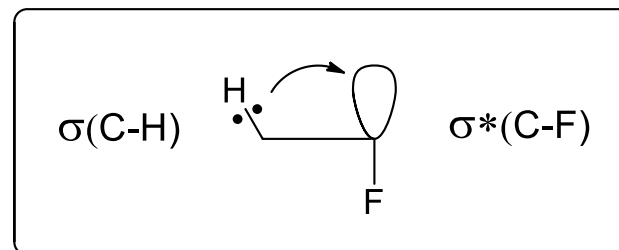

Effects on spectra and structure

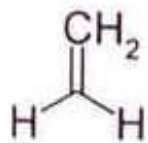

$$\tilde{\nu} \text{C-H} = 3055 \text{ cm}^{-1}$$

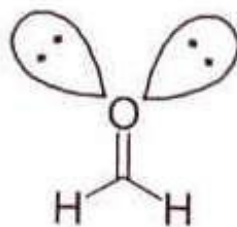

$$\tilde{\nu} \text{C-H} = 2813 \text{ cm}^{-1}$$

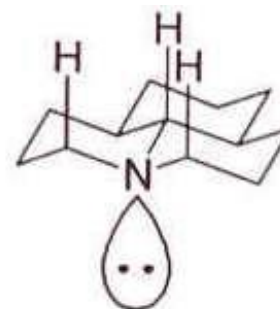

$$\tilde{\nu} \text{C-H} = 2800-2700 \text{ cm}^{-1}$$

Antiperiplanar lone pairs weaken C-H bonds and reduce their IR wavenumber

Stereoelectronic effects and the Baldwin rules

Stereochemical requirements for the S_N2 -substitution: linear arrangement between the leaving group and the entering nucleophile

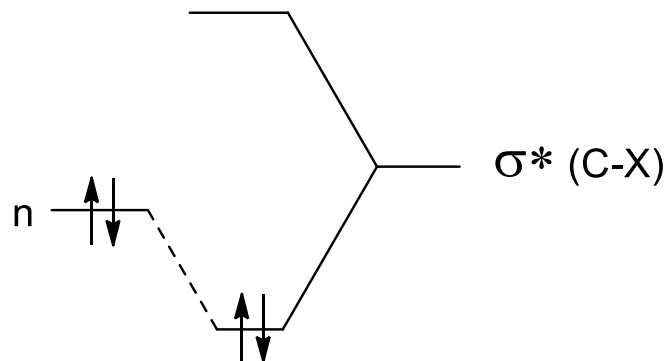
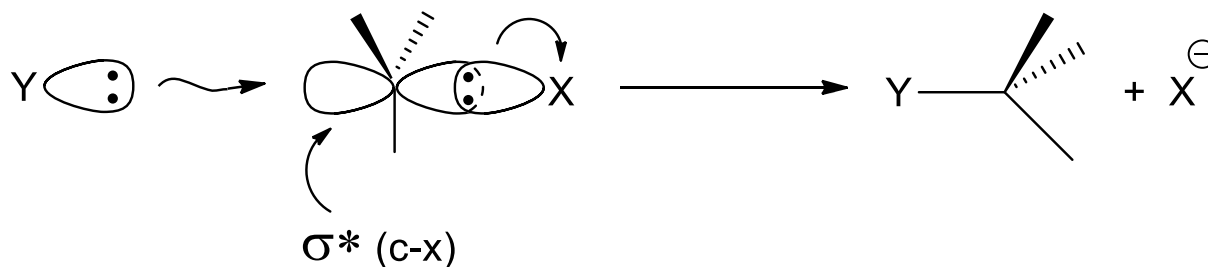

J. E. Baldwin, *J. Chem. Soc., Chem. Commun.*, **1976**, 734-736.

Epoxide-opening

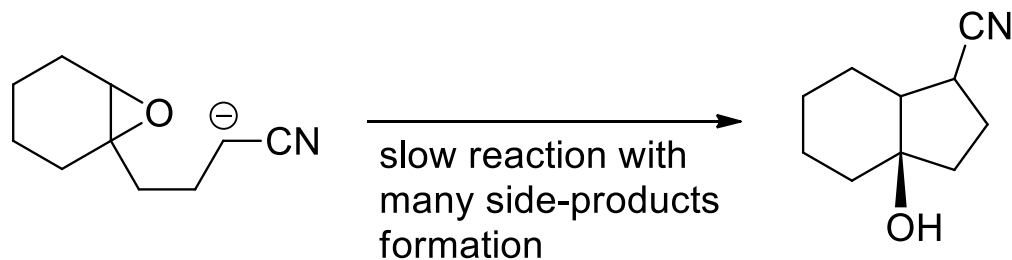
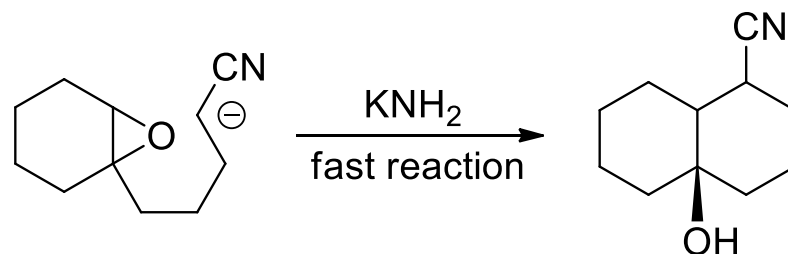
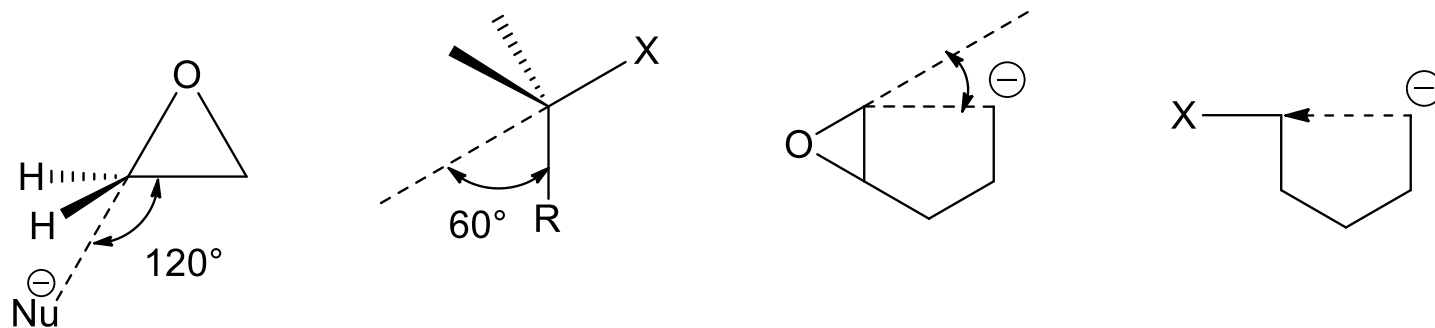

G. Stork, L. D. Cama, D. R. Coulson, *J. Am. Chem. Soc.* **1974**, 96, 5268.

Epoxide-opening

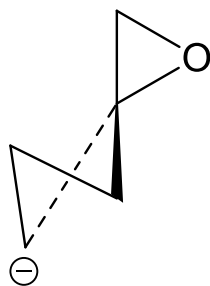

preferred
conformation

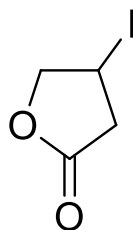
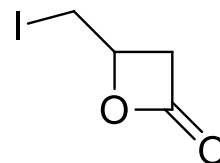
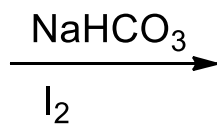
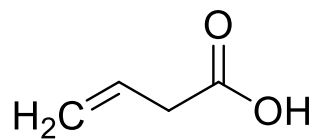
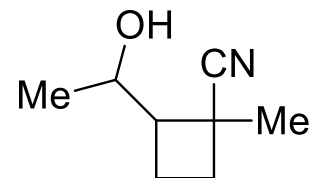
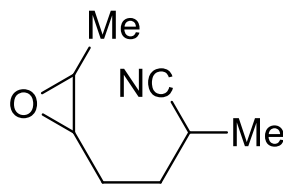

Baldwin rules

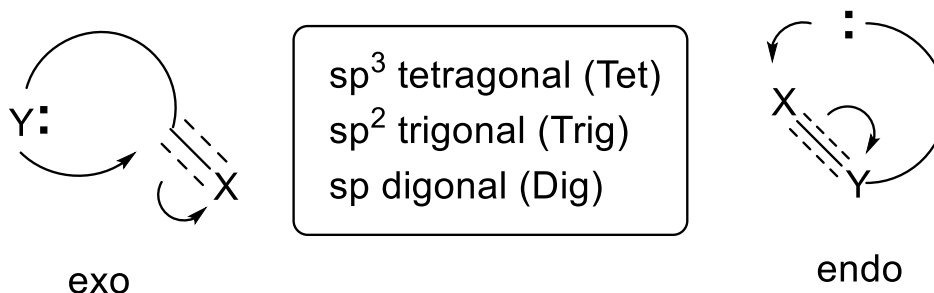

Rule 1: ***Tetrahedral Systems***

3 to 7-*Exo-Tet* are all favoured processes
with many literature precedents
5 to 6-*Endo-Tet* are disfavoured

Rule 2: ***Trigonal Systems***

3 to 7-*Exo-Trig* are all favoured processes
with many literature precedents
3 to 5-*Endo-Trig* are disfavoured
6 to 7-*Endo-Trig* are favoured

Rule 3: ***Digonal Systems***

3 to 4-*Exo-Dig* are disfavoured processes
5 to 7-*Exo-Dig* are favoured
3 to 7-*Endo-Dig* are favoured

Stereoselective reactions

Examples:

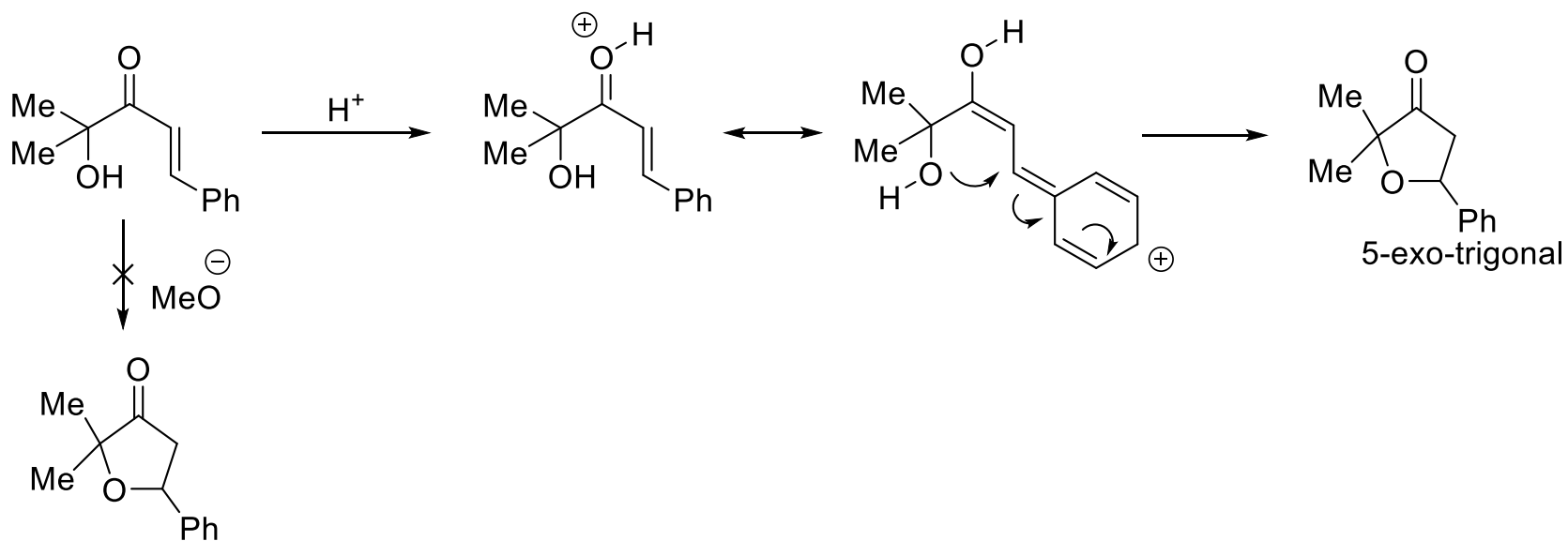

J. E. Baldwin, R. C. Thomas, L. I. Kruse, L. Silberman *J. Org. Chem.* **1977**, 42, 3846.

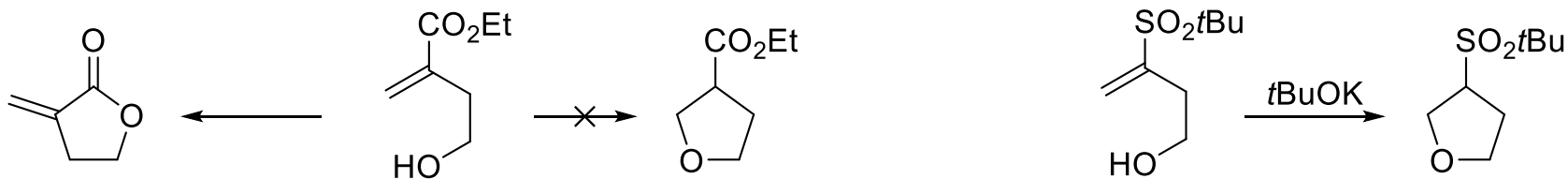

P. Auvray, P. Knochel, J. F. Normant,
Tetrahedron Lett. **1985**, 26, 4455. 102

S_N2' -substitutions

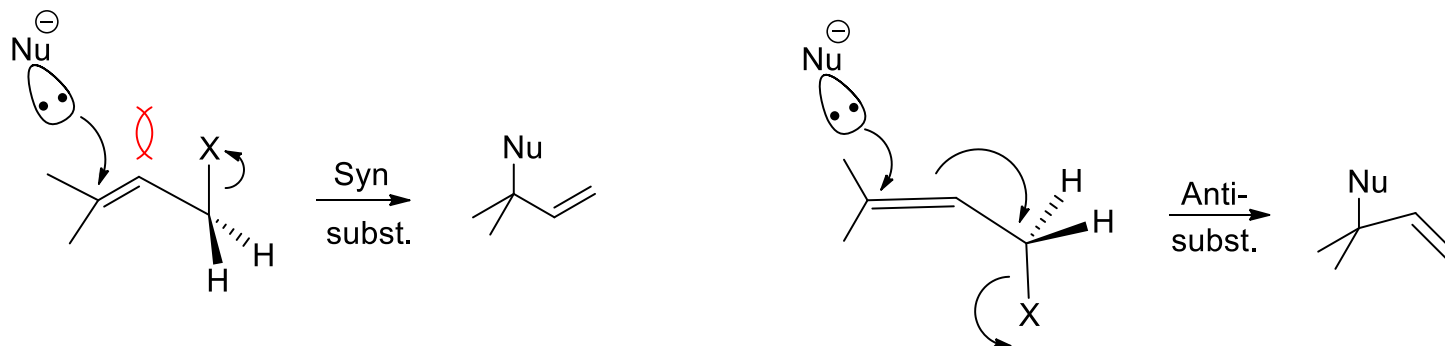

Syn substitutions

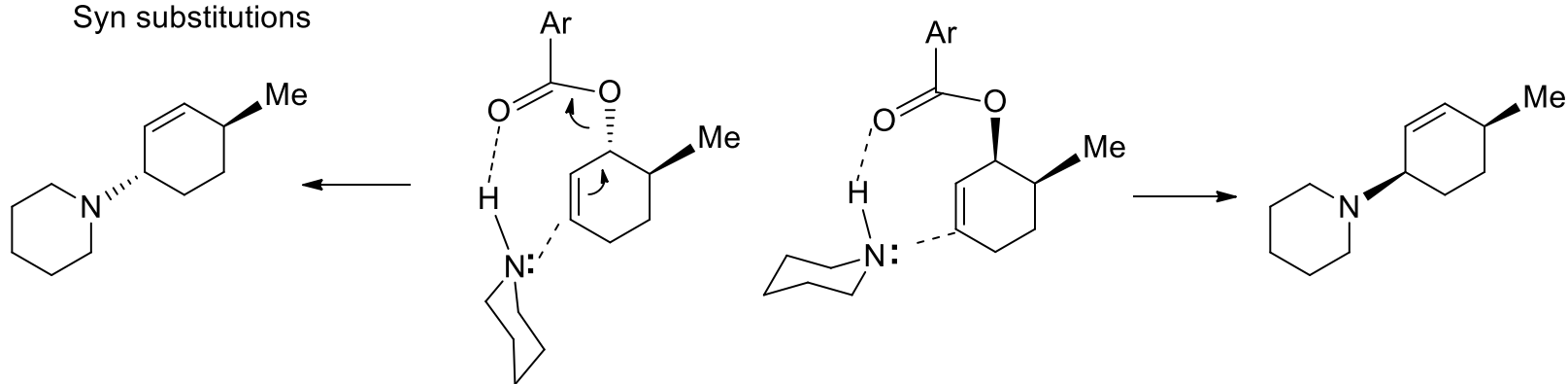

G. Stork, W. N. White, *J. Am. Chem. Soc.* **1956**, 78, 4609. For a review see: R. M. Magid, *Tetrahedron* **1980**, 36, 1901.

S_N2'-substitutions with organocopper

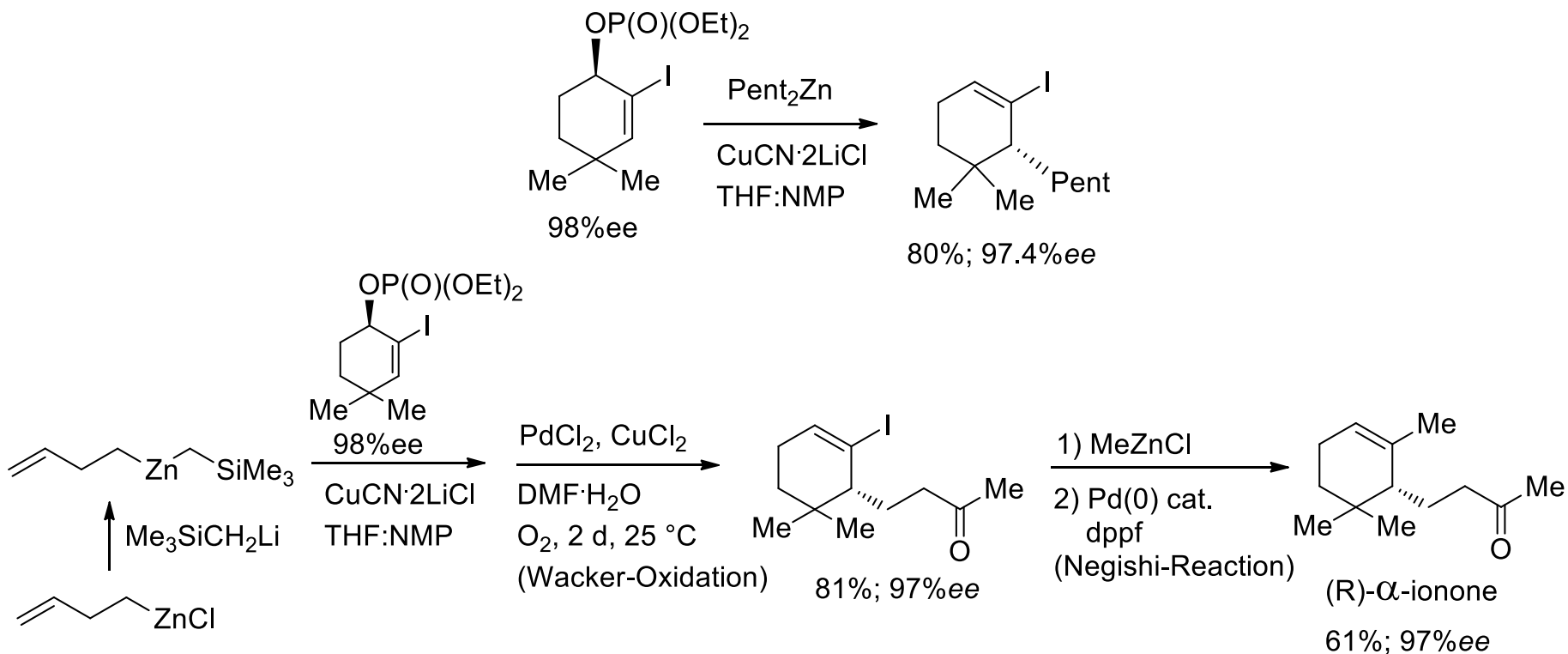

D. Soorukram, P. Knochel *Org. Lett.* **2004**, 6, 2409

Anti-S_N2'-substitutions with organocopper

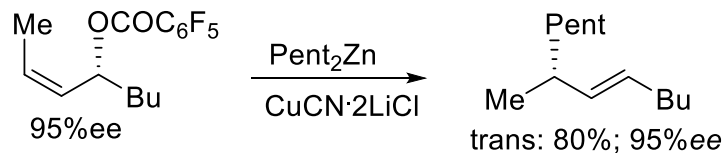
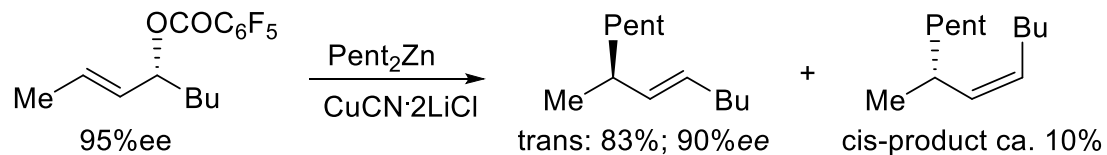

two anti-substitution
TS-structures
are possible:

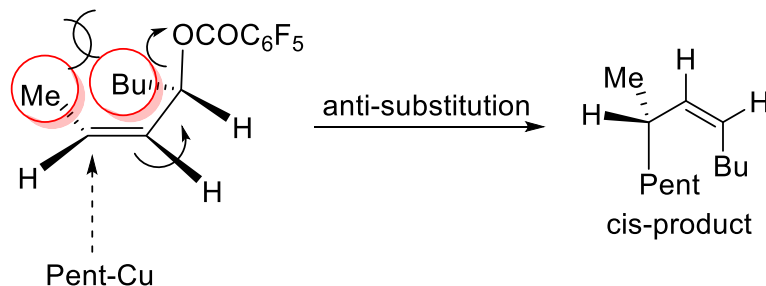
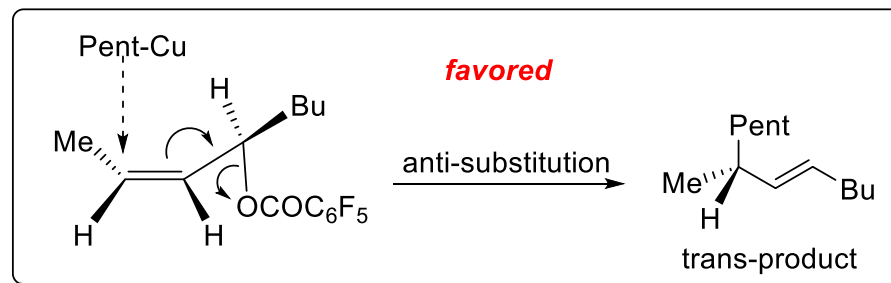

N. Harrington-Frost, H. Leuser, M. I. Calaza, F. F. Kneisel, P. Knochel,
Org. Lett., **2003**, 5, 2111

Anti-substitutions at propargylic systems

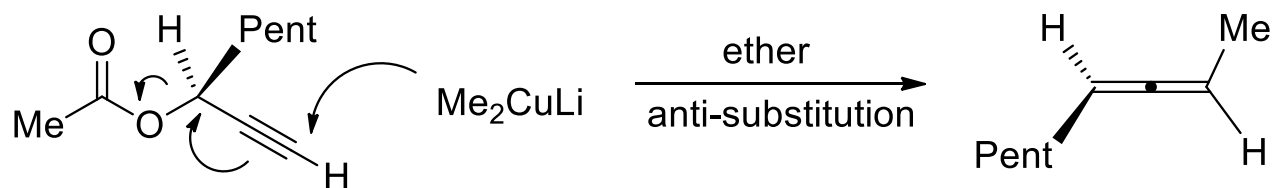

J.-M. Dollat, J.-L. Luche, P. Crabbe *J. Chem. Soc., Chem. Commun.*, **1977**, 761-762

Stereoselective palladium-catalyzed allylic substitutions

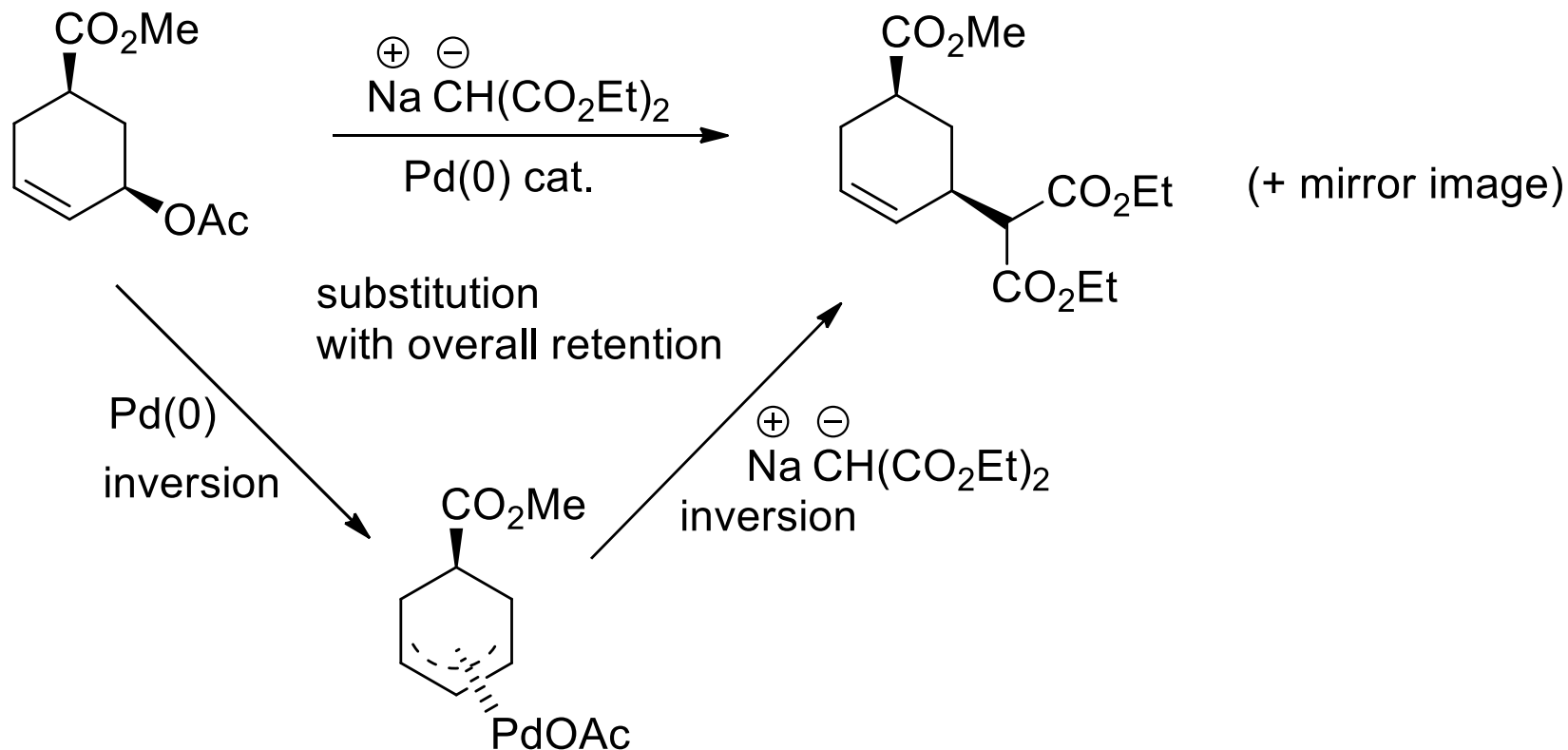

B. M. Trost, *Acc. Chem. Res.* **1980**, 13, 385.

Electrophilic substitutions

S_E2

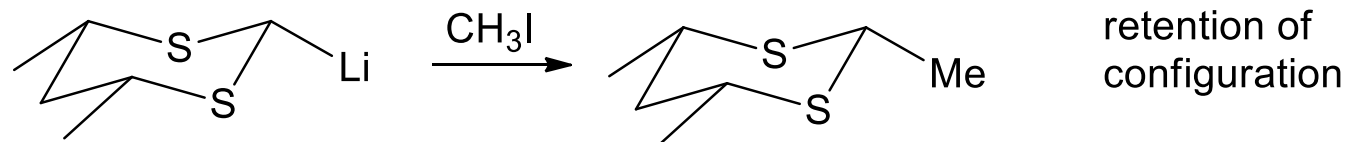
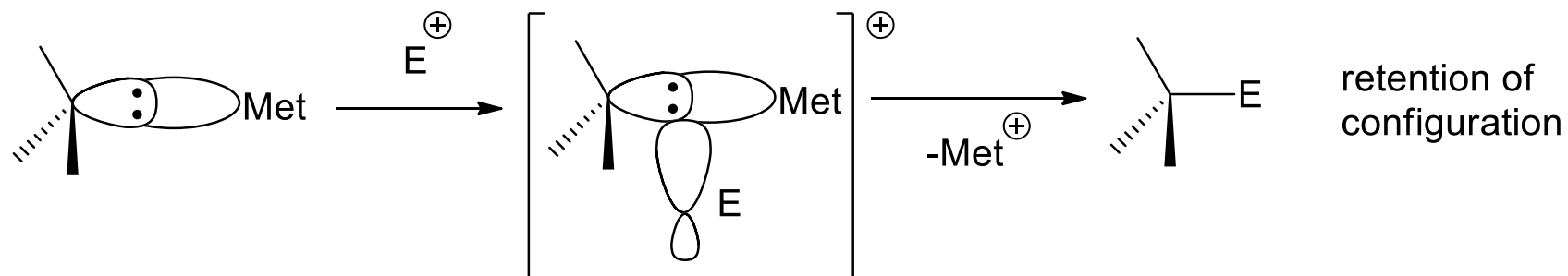

First synthesis of an optically active zinc reagent

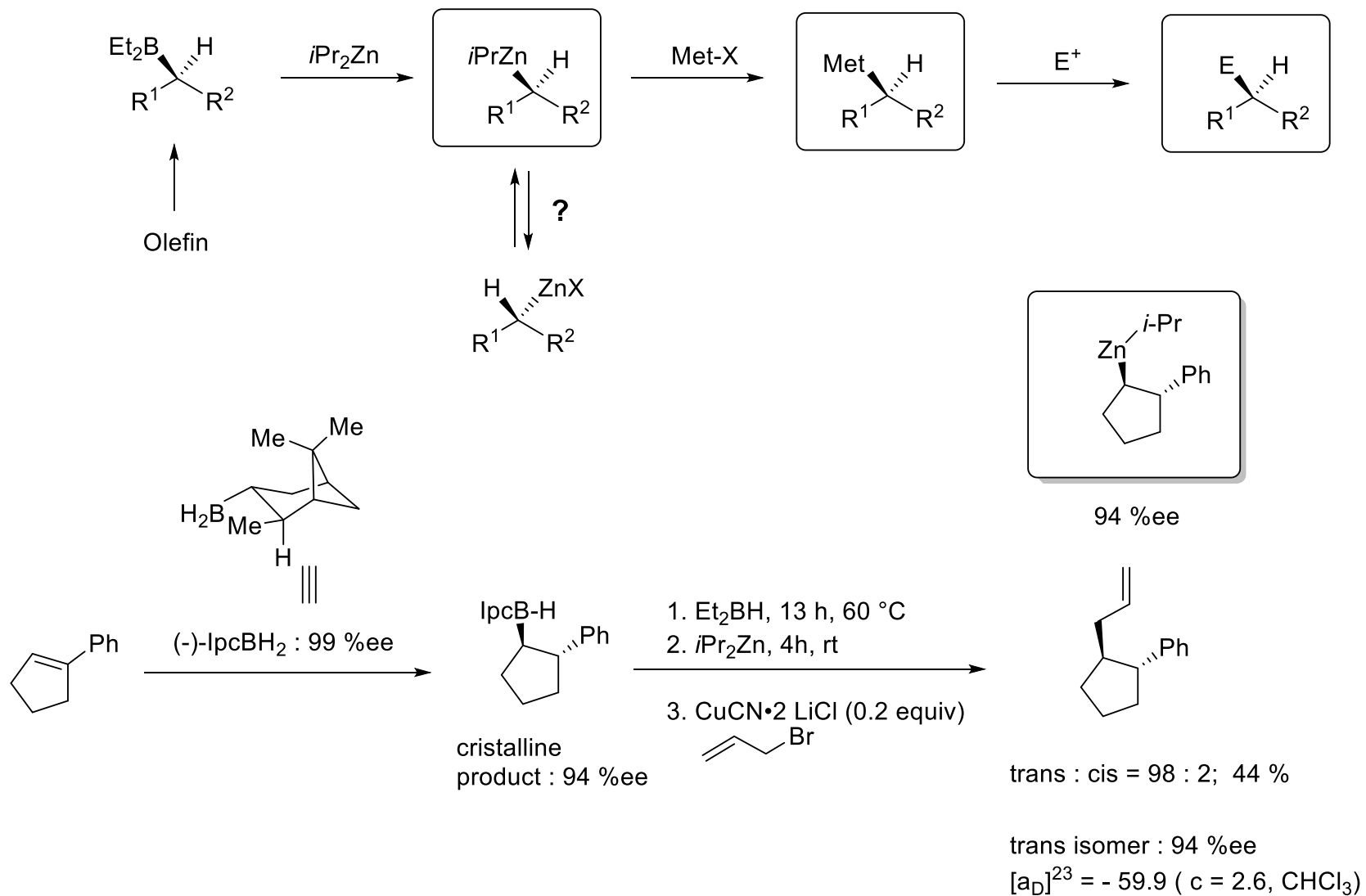

A. Boudier, C. Darcel, F. Flachsmann, L. Micouin, M. Oestreich, P. Knochel, *Chem. Eur. J.* **2000**, 6, 2748;
 C. Darcel, F. Flachsmann, P. Knochel, *J. Chem. Soc., Chem. Commun.* **1998**, 205-209.

Preparation of chiral zinc reagents

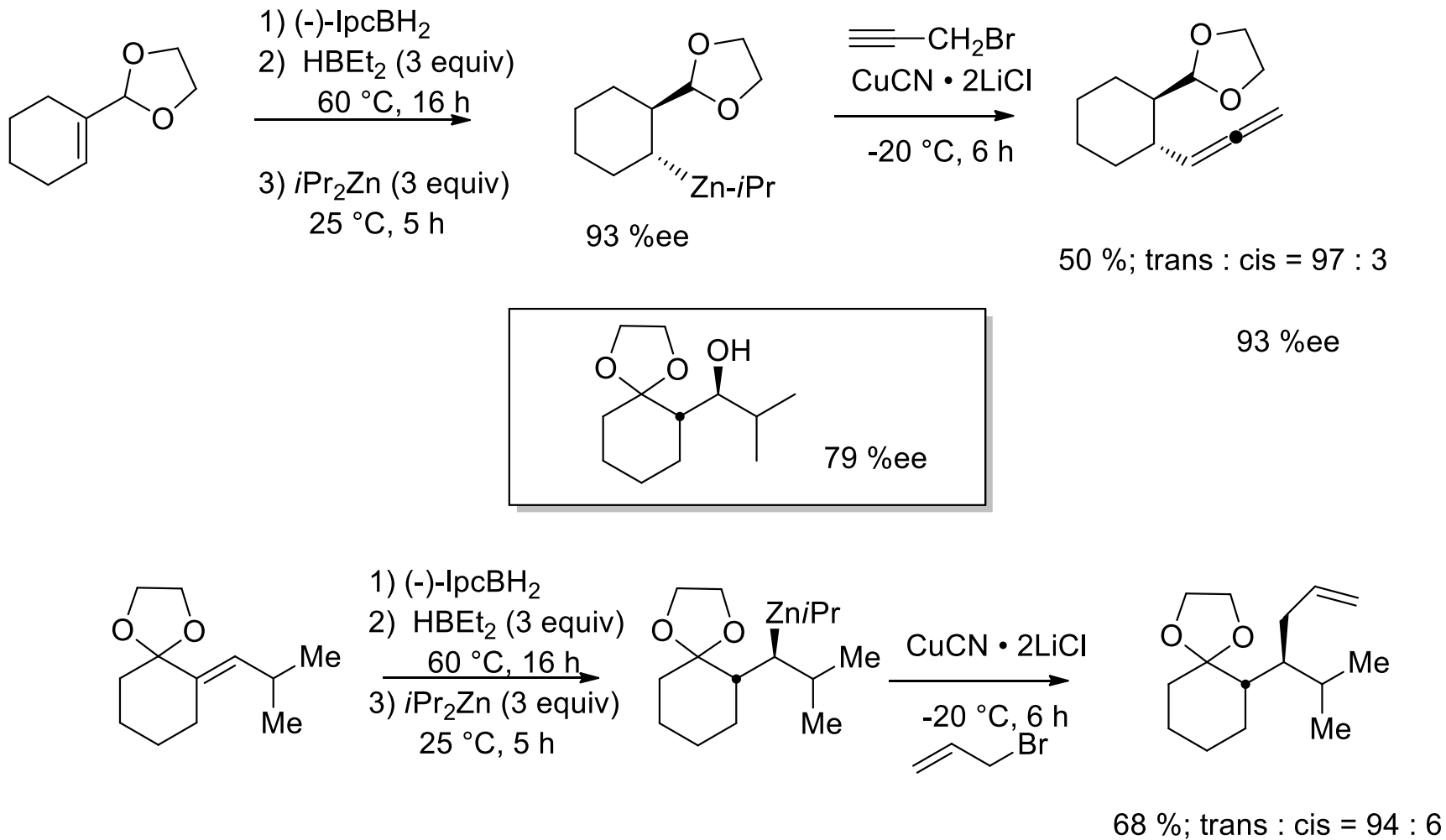

E. Hupe, Knochel, *P. Angew. Chem. Int. Ed.* **2001**, *40*, 3022

Enantiomerically enriched secondary alkyllithium reagents

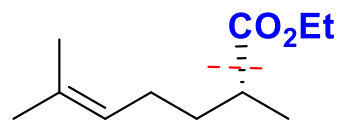
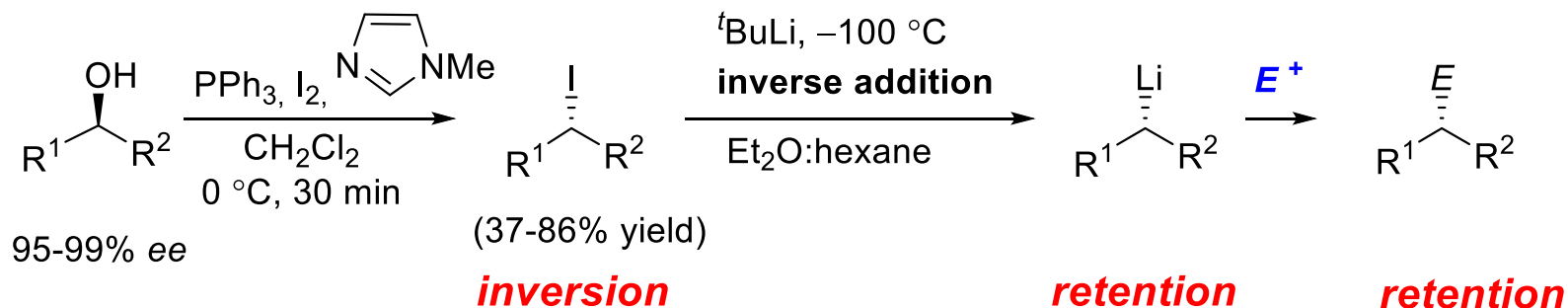

56% yield, 96% ee
(from 98% ee)

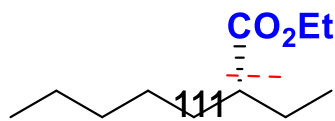

54% yield, 92% ee
(from 95% ee)

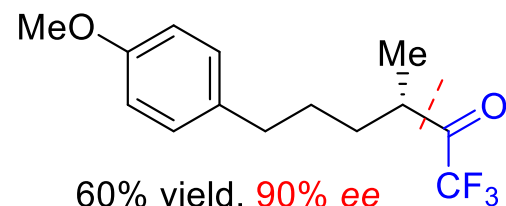

60% yield, 90% ee
(from 98% ee)

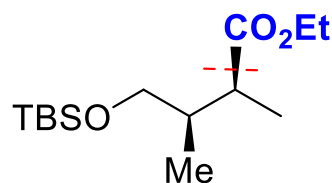

70% yield, 99% ee,
d.r.=95:5
(from 99% ee and d.r.=98:2)

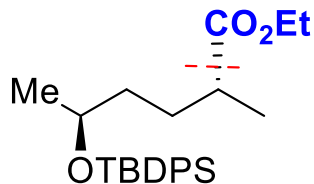

62% yield, 99% ee,
d.r.=99:1
(from 99% ee and d.r.=99:1)

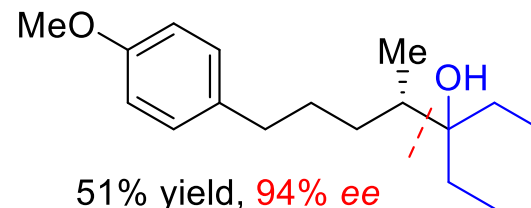

51% yield, 94% ee
(from 98% ee)

S_N2- and S_N2'-substitutions with secondary alkylcoppers

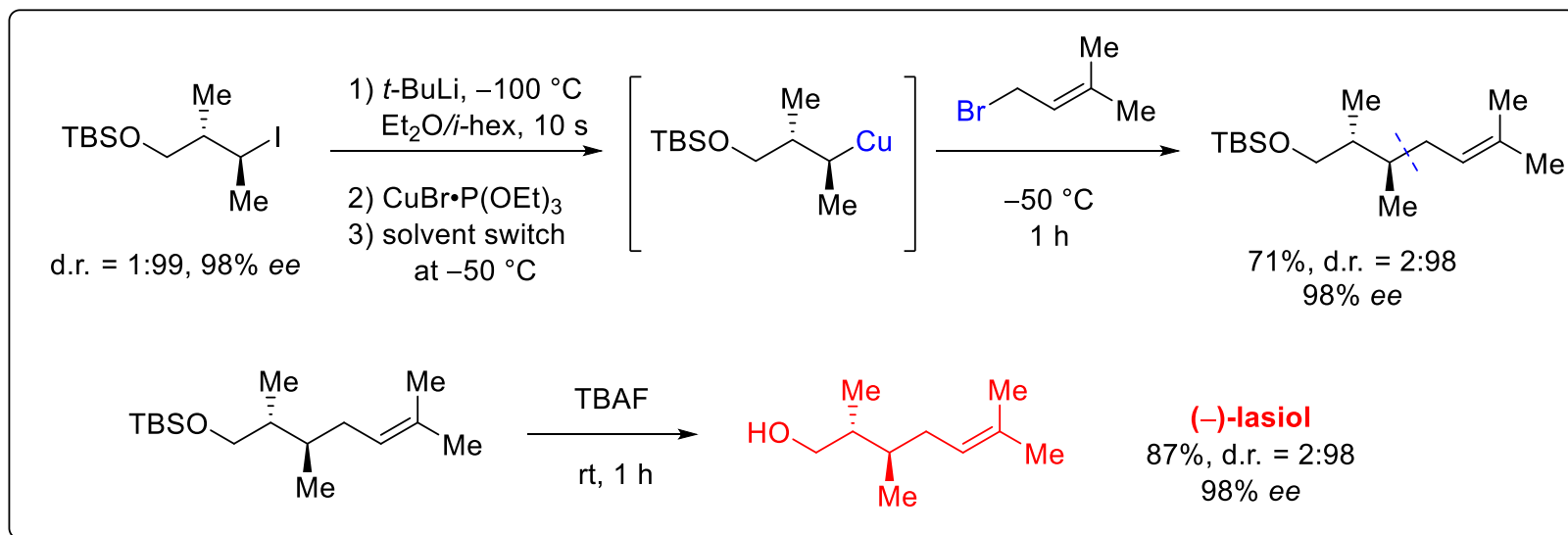
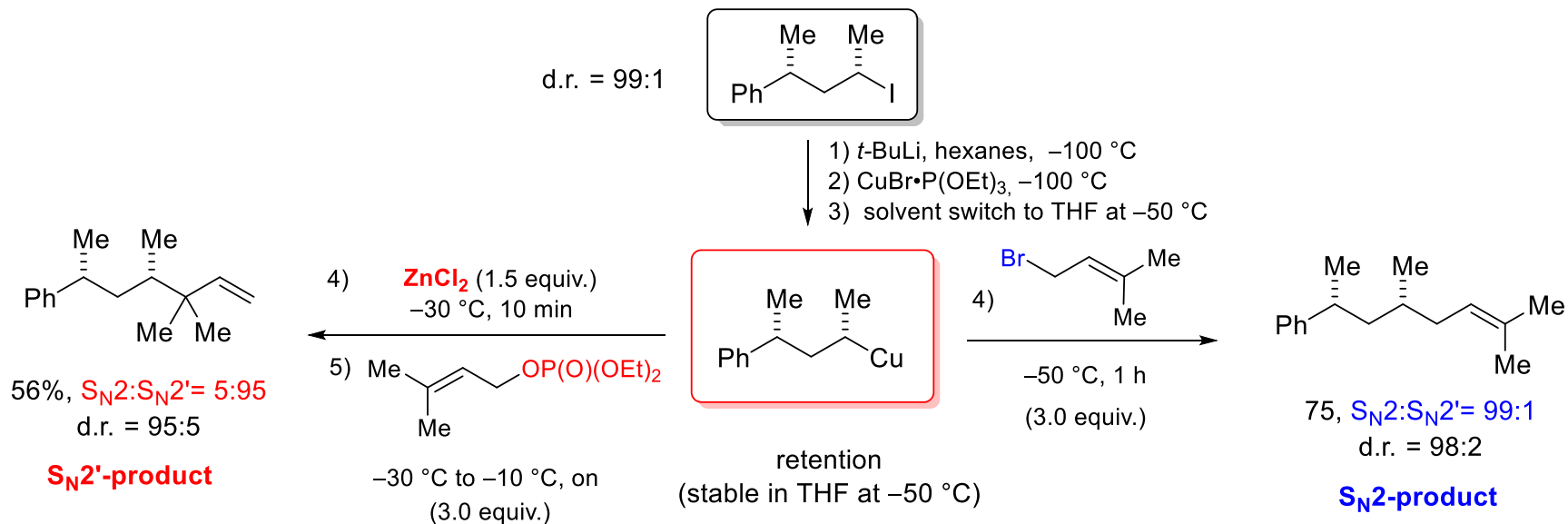

Synthesis of (-)-lardolure using chiral lithium and chiral copper reagents

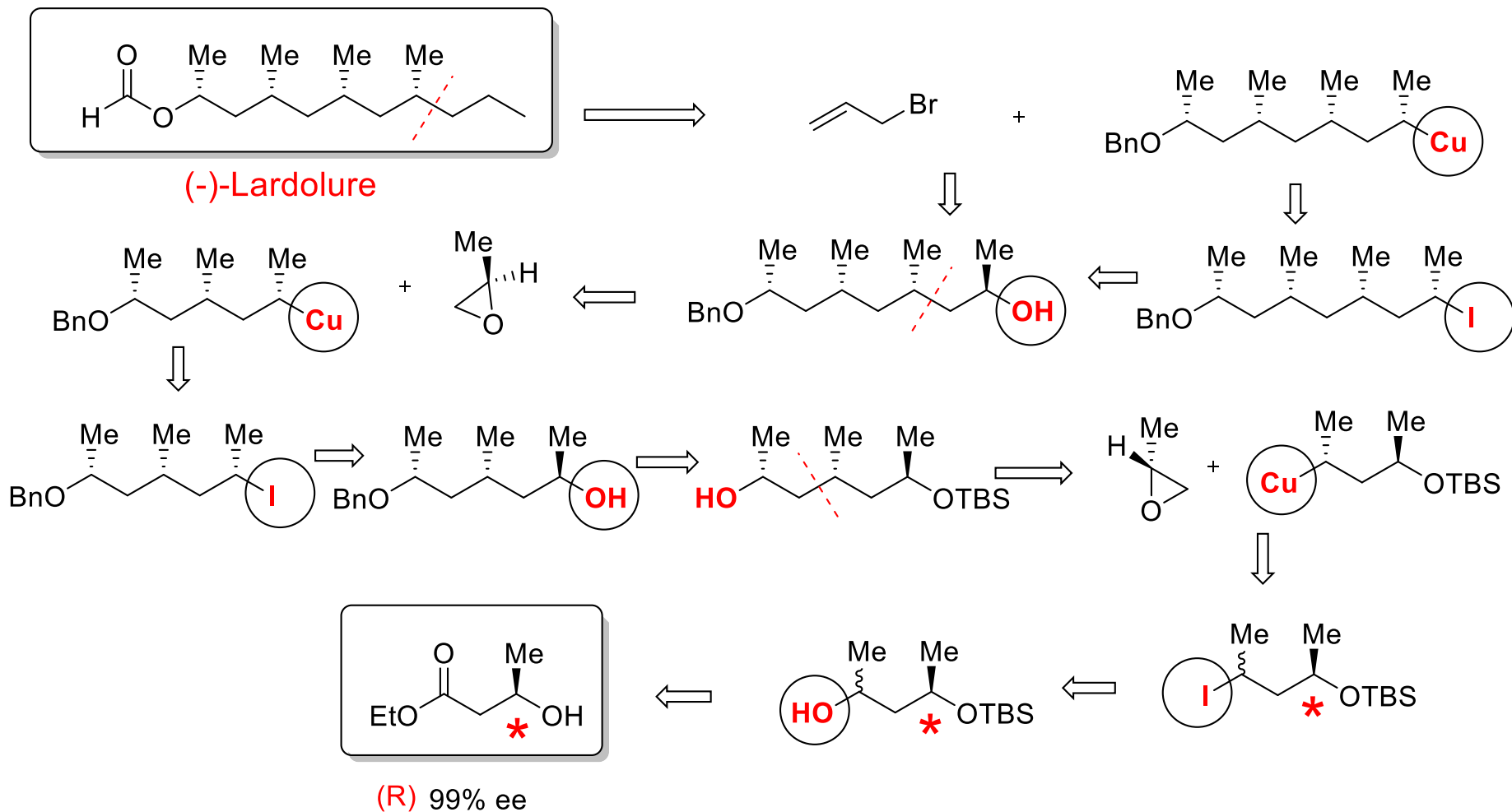

Morozova, V.; Skotnitzki, J.; Moriya, K.; Karaghiosoff, K.; Knochel, P. *Angew. Chem., Int. Ed.* **2018**, *57*, 5516-5519.

Synthesis of (-)-lardolure using enantiomerically enriched Li- and Cu-reagents

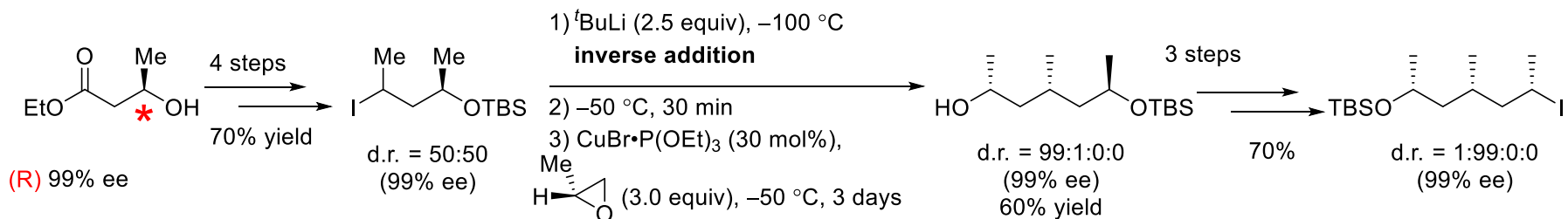

Cu-catalyzed epoxide opening

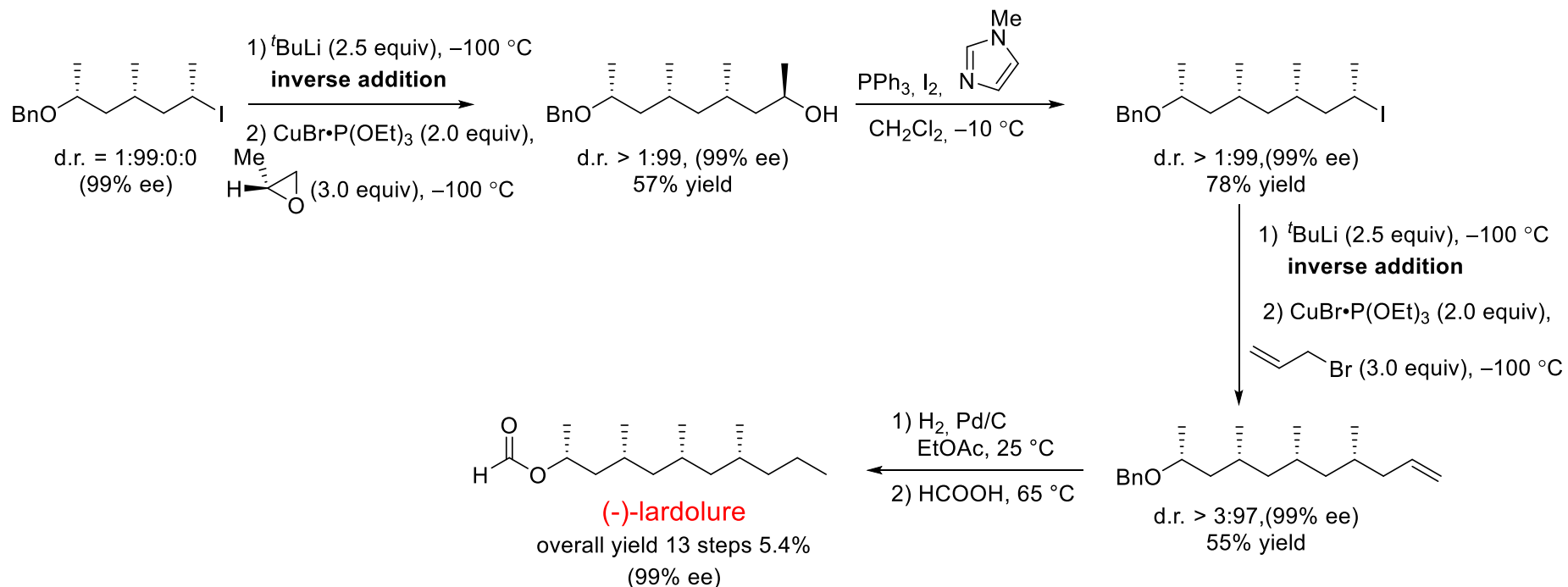

Morozova, V.; Skotnitzki, J.; Moriya, K.; Karaghiosoff, K.; Knochel, P. *Angew. Chem., Int. Ed.* **2018**, *57*, 5516-5519.

Nucleophilic addition to ketones and aldehydes

Cram-rule

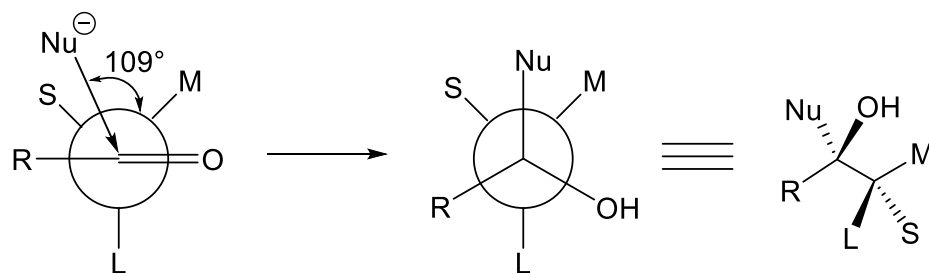
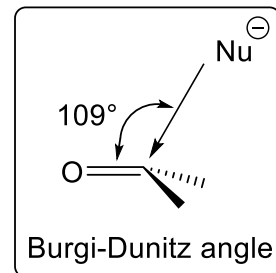
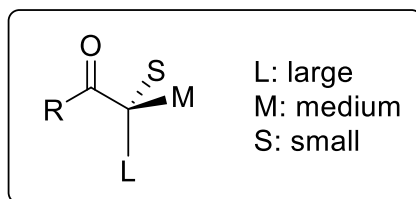

preferred direction
of the addition

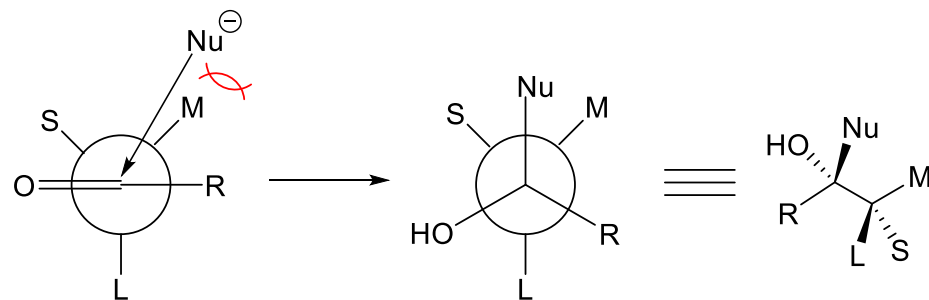

preferred direction
of the addition

Diastereoselective reactions

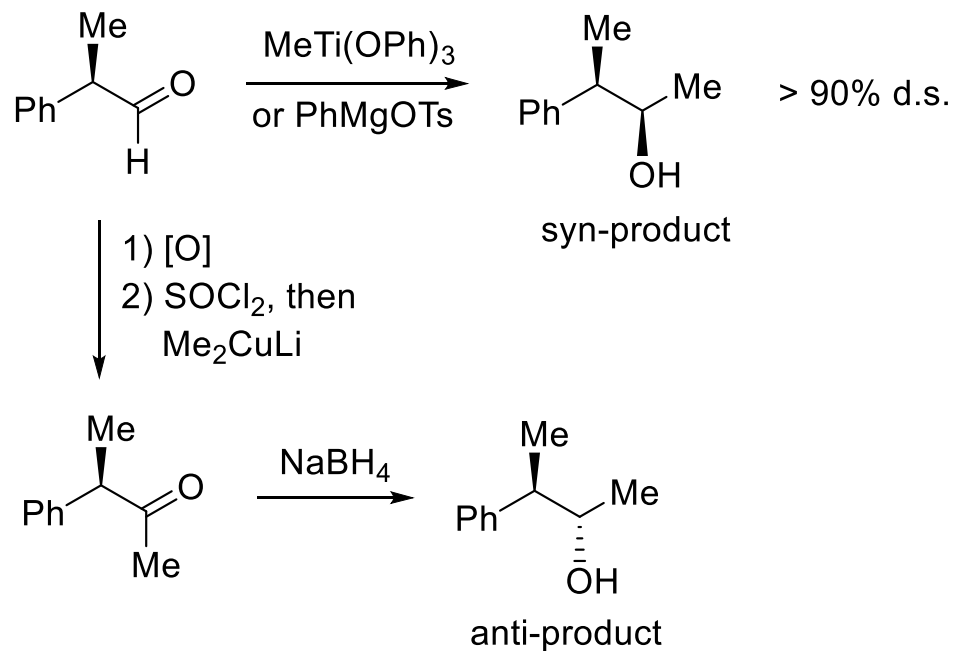

Chelate model

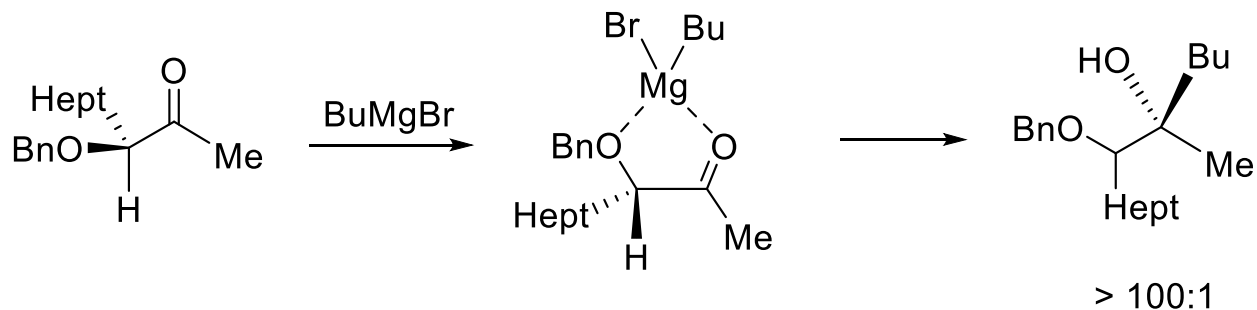

The aldol reaction: the acidity of various C-H bonds

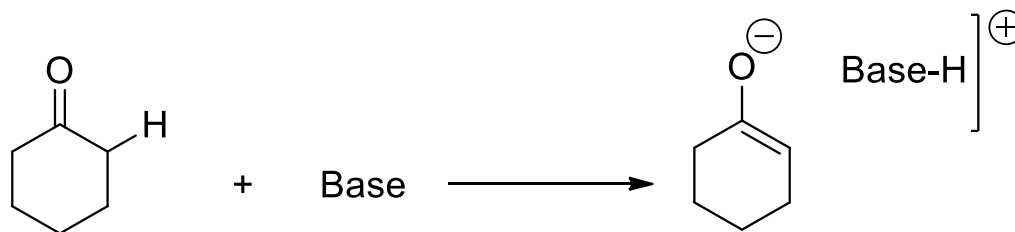

	pK_{DMSO}
MeCH ₂ -NO ₂	16.7
PhCOCH ₃	24.7
EtCOCH ₂ Me	27.1
PhSO ₂ CH ₃	29.0
(Me ₃ Si) ₂ NH	30.0
CH ₃ CN	31.0
<i>i</i> -Pr ₂ NH	35.0
PhCH ₃	43.0
CH ₄	56.0

Bordwell acidity scale in DMSO: *Acc. Chem. Res.* **1988**, 21, 456.

The aldol reaction

Kinetic control:

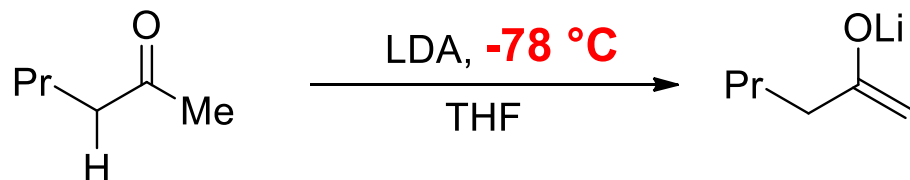

Thermodynamic control:

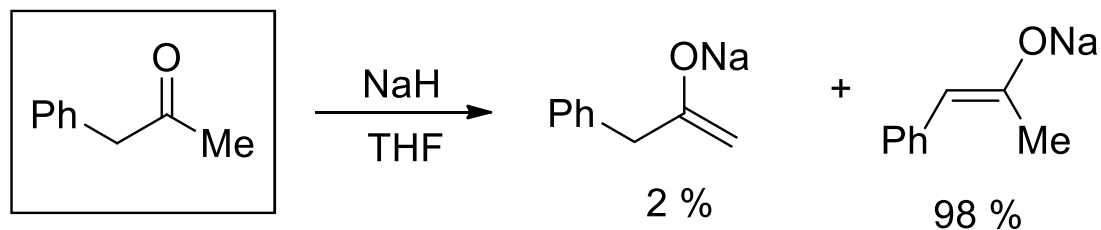
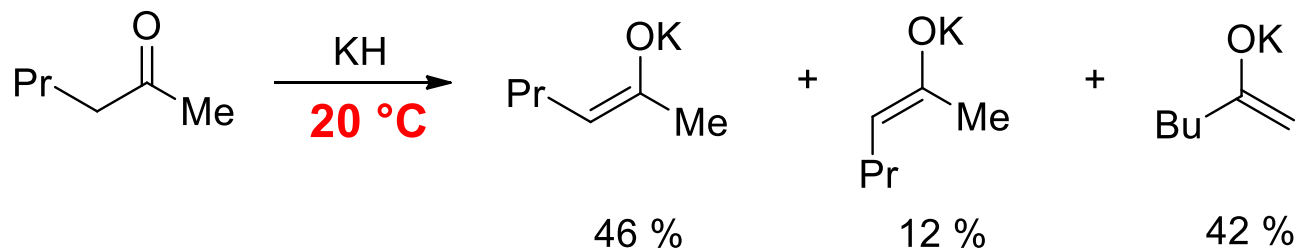

The aldol reaction

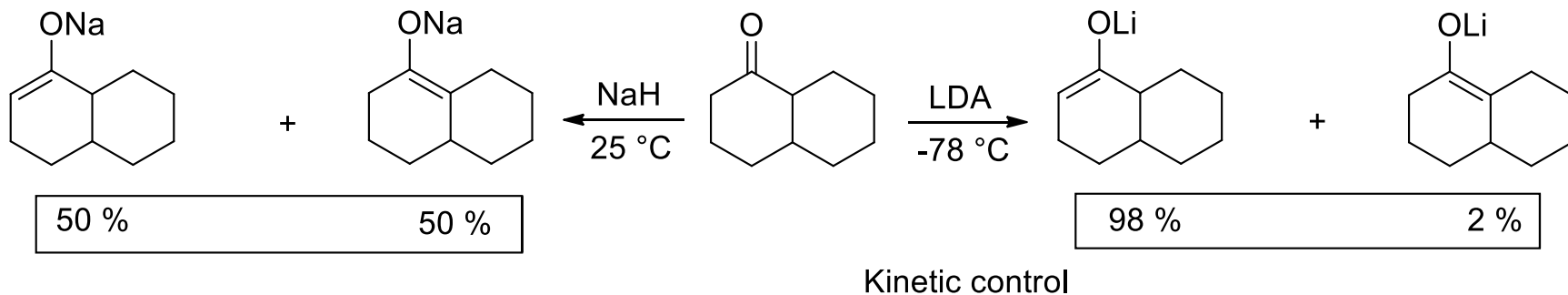

Enantioselective deprotonation: kinetic resolution

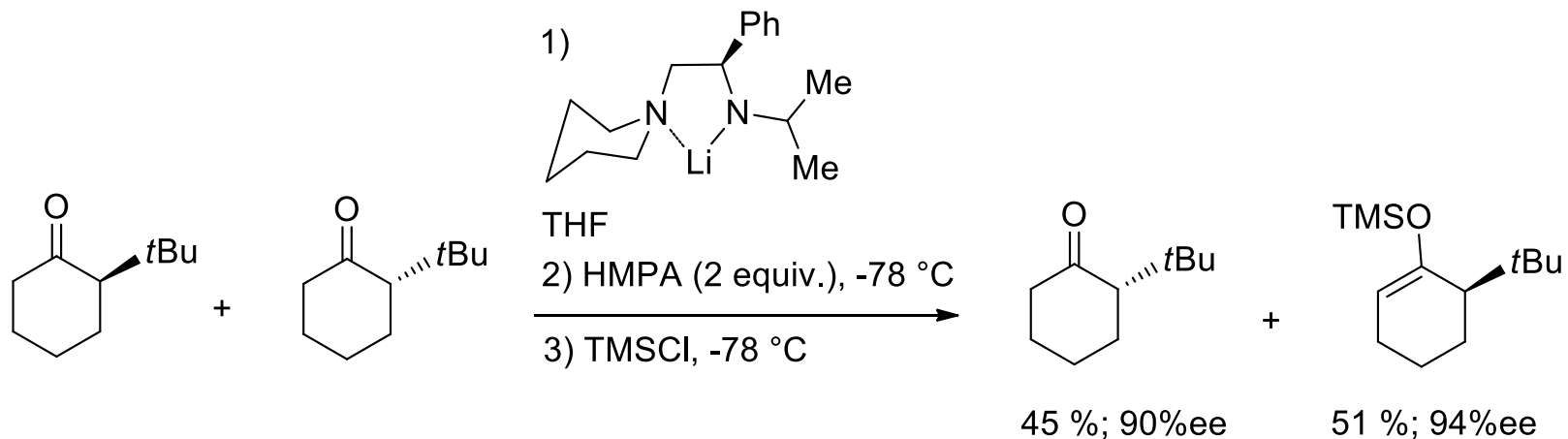

R. Shirai, M. Tanaka, K. Koga, *J. Am. Chem. Soc.* **1986**, *108*, 543.

Stereoselectivity in the aldol reaction

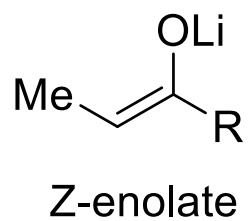

+

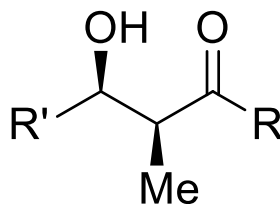
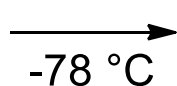

via

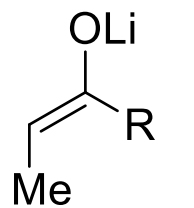
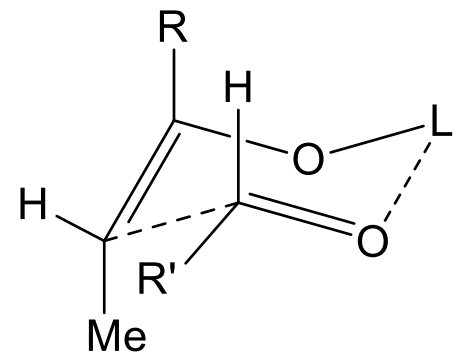

+

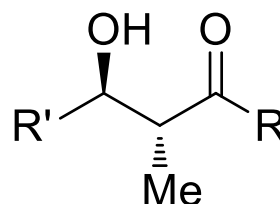
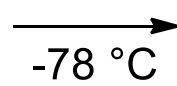

via

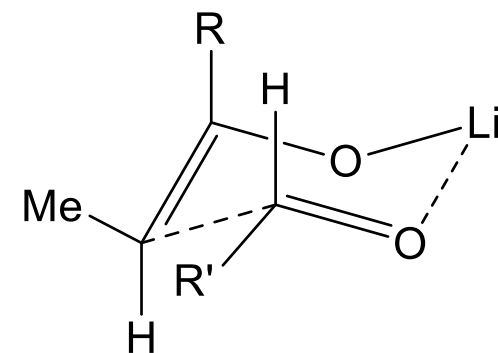

Enantioselective aldol synthesis

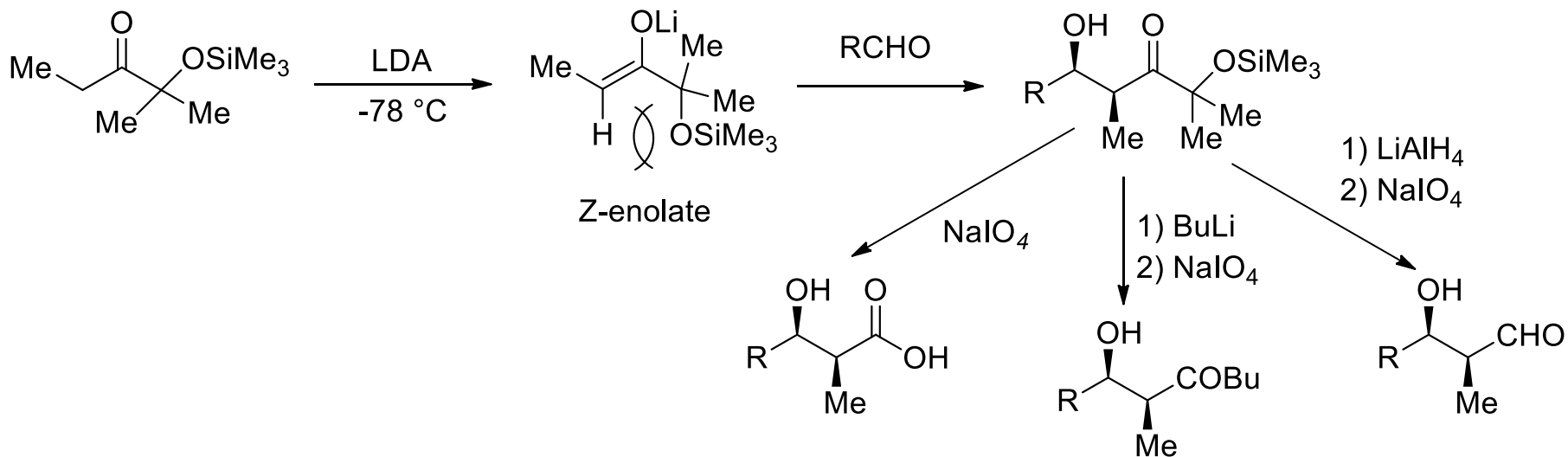

C. Heathcock, *J. Am. Chem. Soc.* **1977**, *99*, 2337;
J. Org. Chem. **1981**, *46*, 191;
J. Org. Chem. **1985**, *50*, 2095.

The aldol reaction

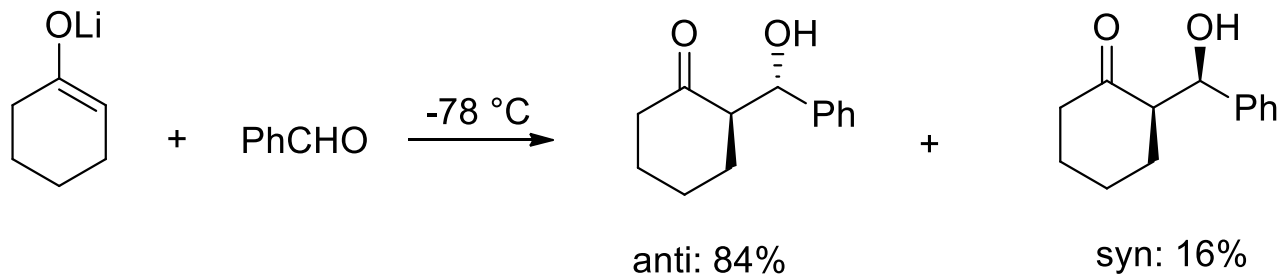

M. Majewski, D. M. Gleave, *Tetrahedron Lett.* **1989**, 30, 5681.

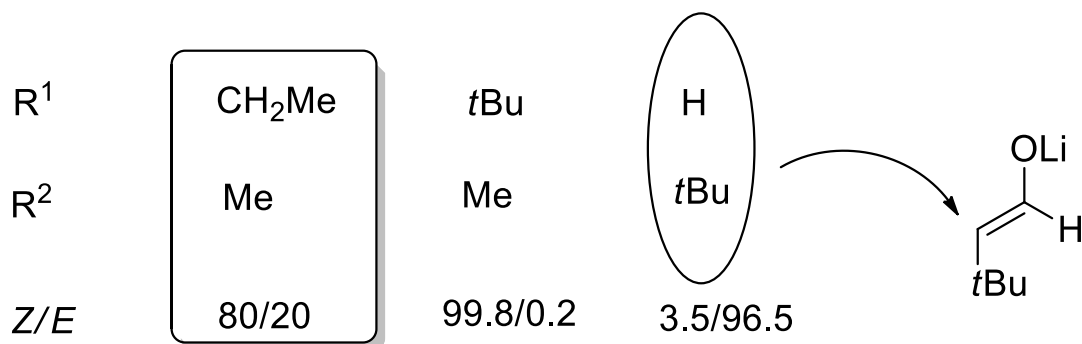
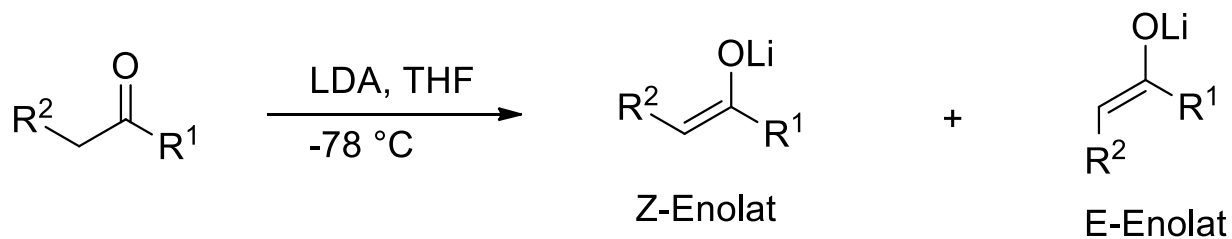

unselective stereoselective enolization with Li-bases

The aldol reaction

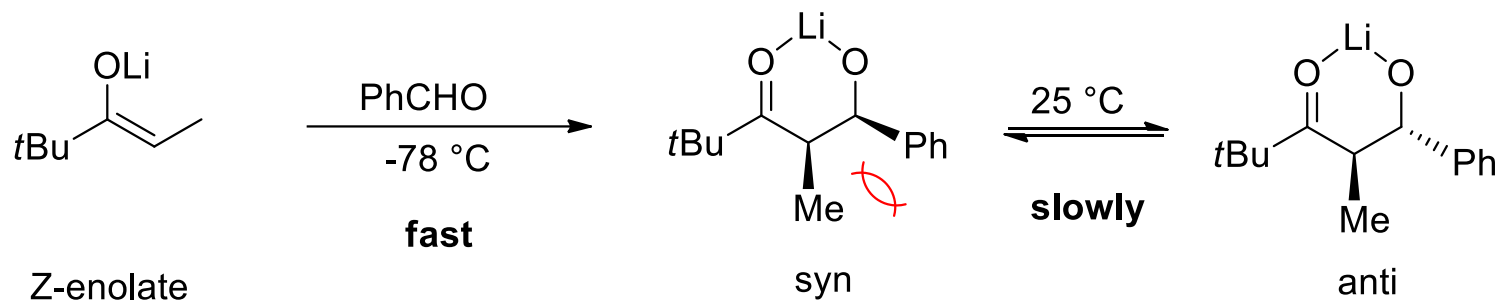

C. H. Heathcock, J. Lampe, *J. Org. Chem.* **1983**, 48, 4330.

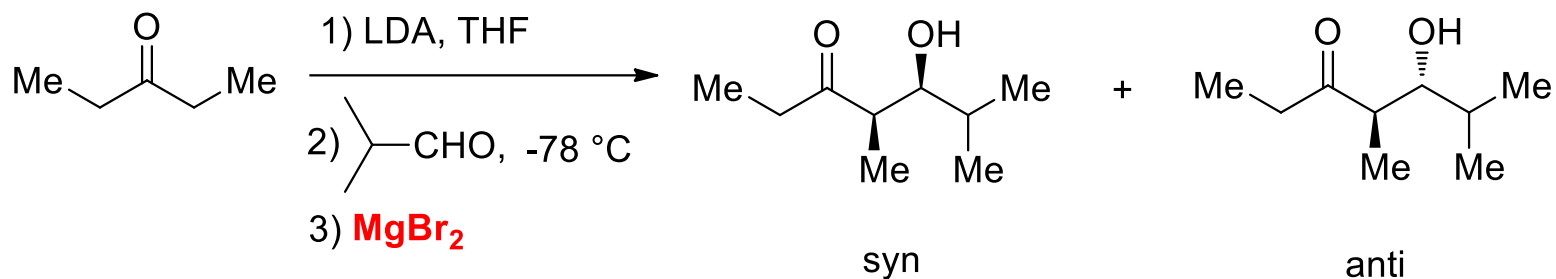

Kinetic control at $-78\text{ }^\circ\text{C}$: syn : anti = 31 : 69

Thermodynamic control at $25\text{ }^\circ\text{C}$: syn : anti = 9 : 91

K. A. Swiss, W. B. Choi, D. C. Liotta, A. F. Abdel-Magid, C. A. Maryanoff, *J. Org. Chem.* **1991**, 56, 5978.

The aldol reaction

General synthesis of Z-enolates

Boron enolates are usually more selective than Li-enolates

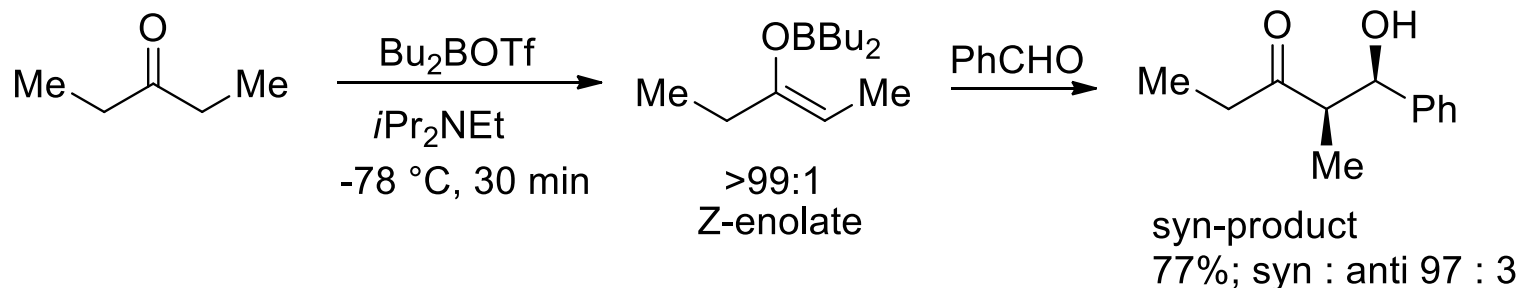

D. A. Evans, E. Vogel, J. V. Nelson, *J. Am. Chem. Soc.* **1979**, 101, 6120.

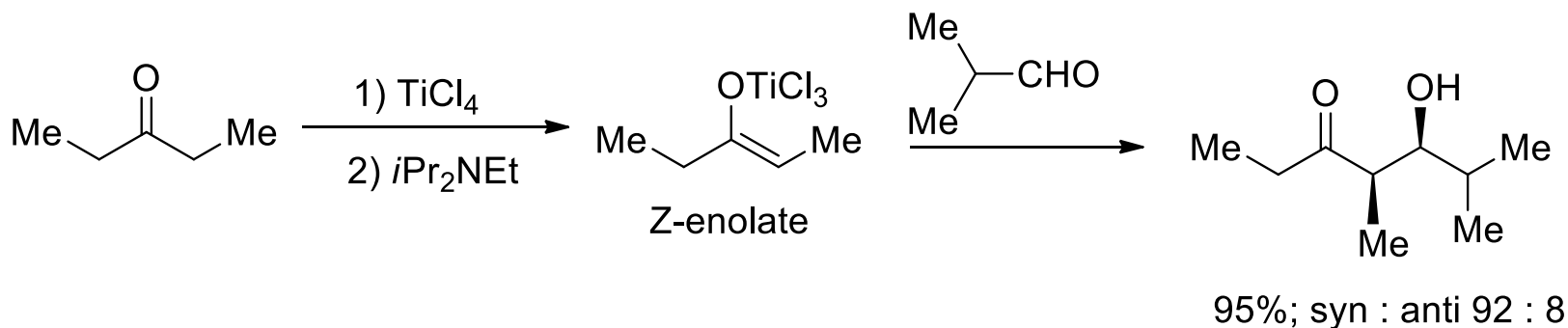

C. Siegel, E. R. Thornton, *J. Am. Chem. Soc.* **1989**, 111, 5722.

D. A. Evans, D. L. Rieger, M. T. Bilodeau, F. Urpi, *J. Am. Chem. Soc.* **1991**, 113, 1047.

Enantioselective aldol reaction

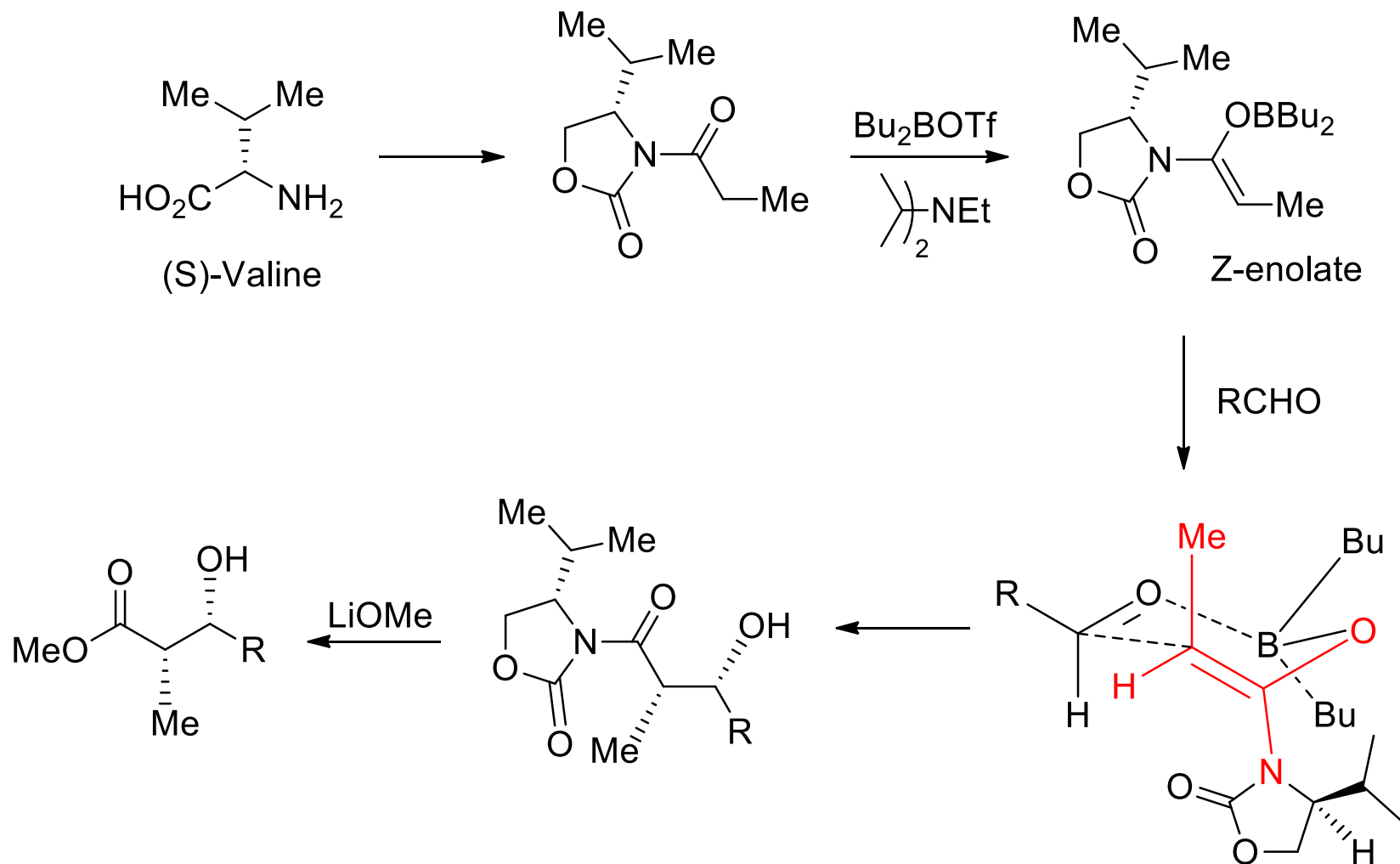

D. A. Evans, *J. Am. Chem. Soc.* **1981**, *103*, 2876.

Enantioselective aldol reaction via Ti-enolates

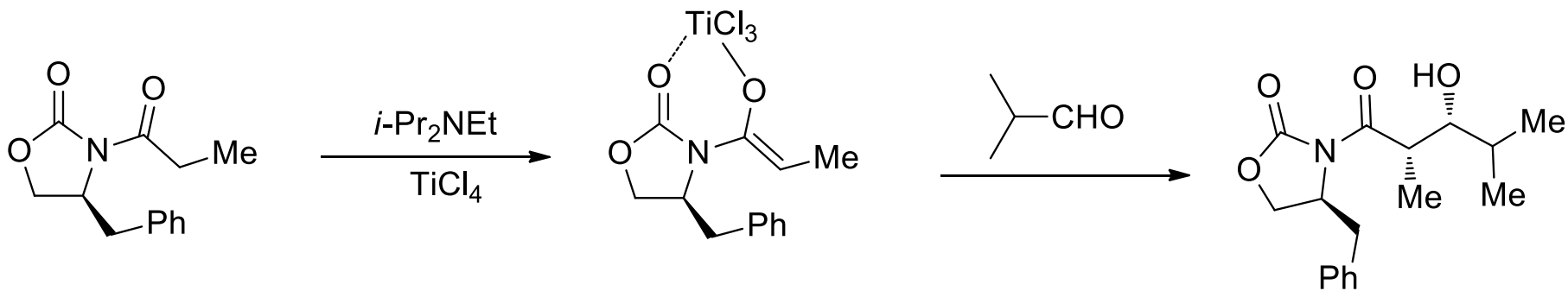

D. A. Evans, *J. Am. Chem. Soc.* **1991**, 113, 1047.

87 %; syn : anti = 94 : 6

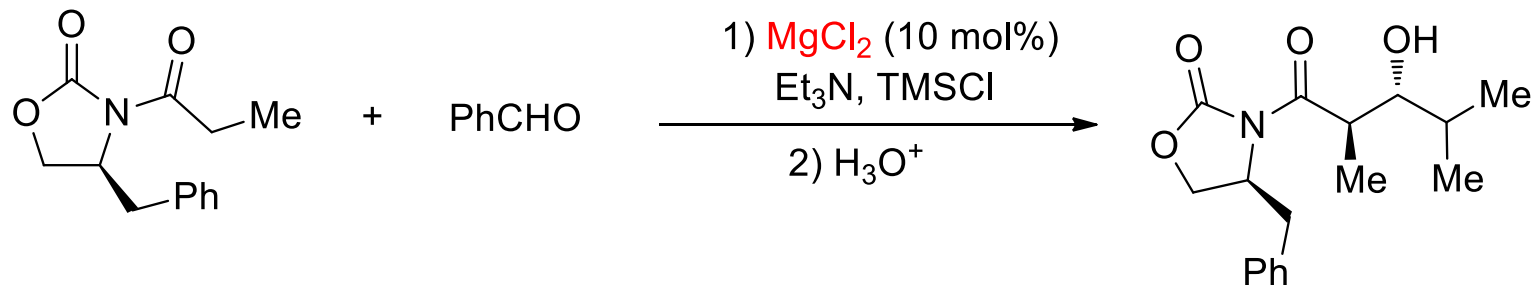

D. A. Evans, *J. Am. Chem. Soc.* **2002**, 124, 392.

91 %; syn : anti = 1 : 32

Enantioselective enolate synthesis

Asymmetric Mukaiyama reaction

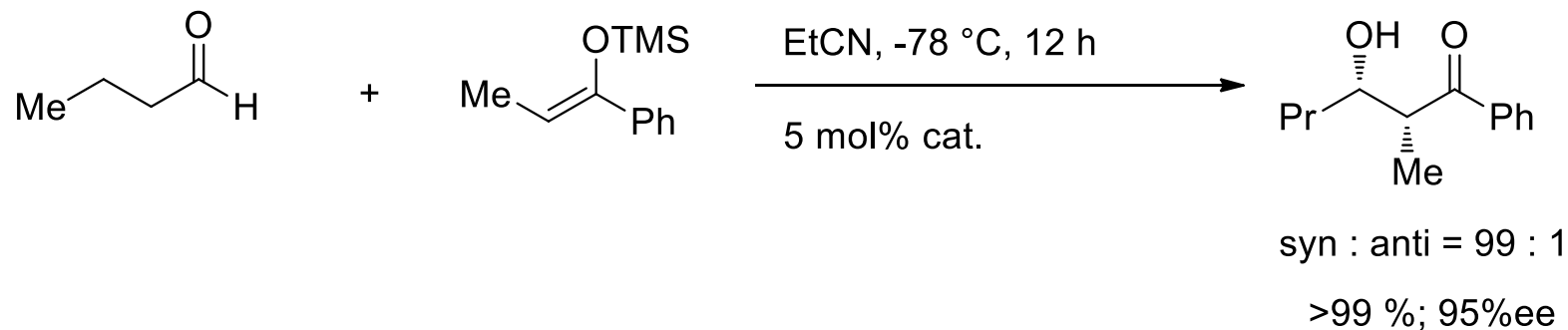

H. Yamamoto, *J. Org. Chem.* **2000**, 65, 9125

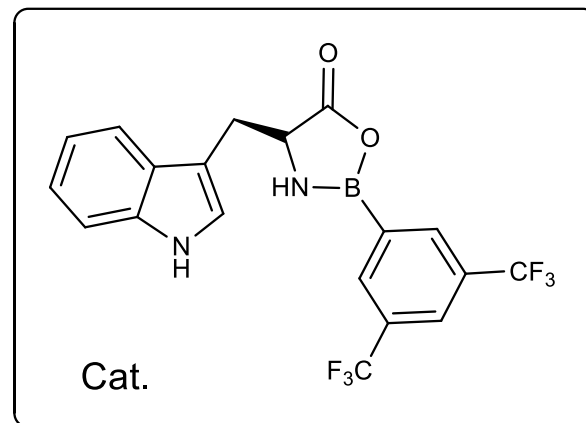

Enantioselective enolate synthesis

Organocatalysis

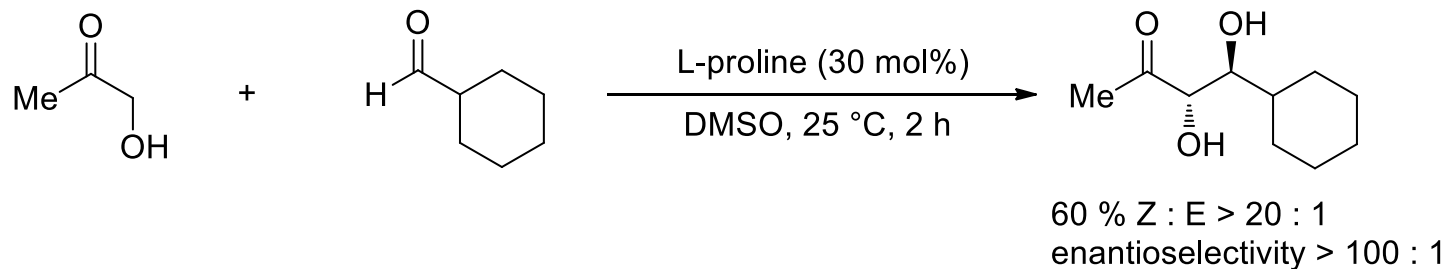

B. List, *J. Am. Chem. Soc.* **2000**, 122, 7386; *Org. Lett.* **2001**, 3, 573.

Review: B. List, *Synlett*, **2001**, 1663.

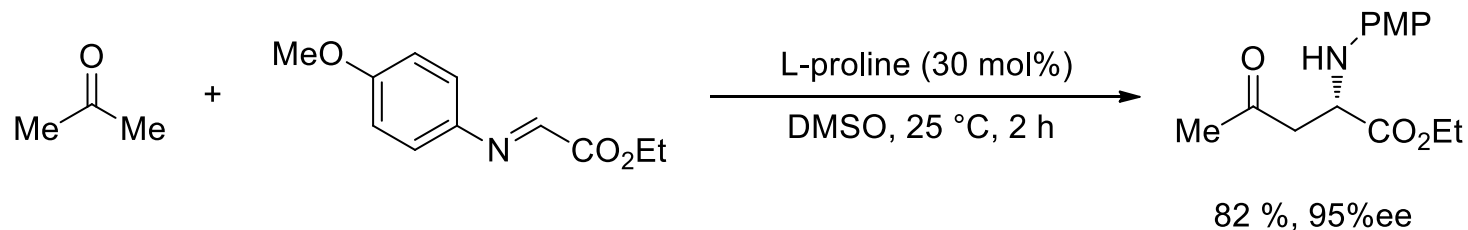

W. J. Liu, N. Li, L. Z. Gong, *Asymmetric Organocatalysis*, Topics in Organometallic Chemistry, **2011**, Vol. 36/2011, 153-205.

U. Scheffler, R. Mahrwald, *Synlett* **2011**, 1660.

H. Pellissier, *Adv. Synth. Catal.* **2011**, 353, 659.

S. G. Zlotin, A. S. Kucherenko, I. P. Beletskaya, *Russian Chem. Rev.* **2009**, 7, 737.

D. Enders, C. Wang, J. X. Liebich, *Chem. Eur. J.* **2009**, 15, 11058.

H. Pellissier, *Tetrahedron* **2007**, 63, 9267.

A. Cordova, W. Notz, G. Zhong, J. M. Betancort, C. F. Barbas, *J. Am. Chem. Soc.* **2002**, 124, 1842.

The aldol reaction via ester enolates – the Ireland-Claisen reaction

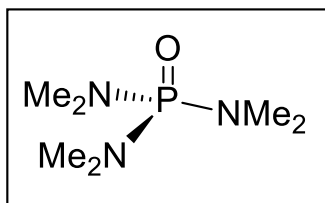
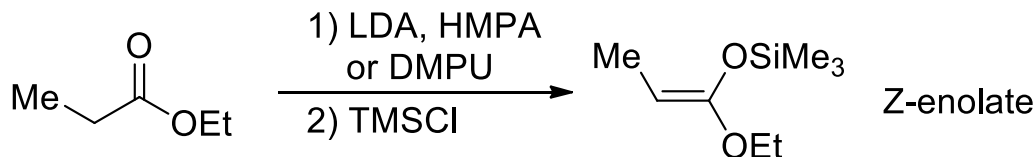
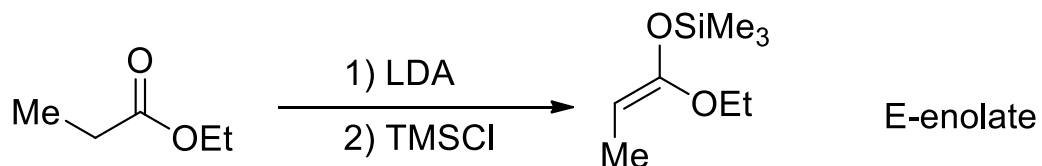

HMPA

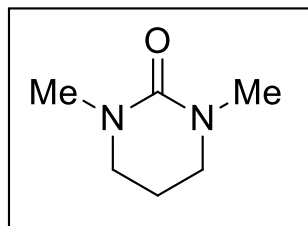

DMPU

Review: D. Enders, M. Knopp, R. Schiffers, *Tetrahedron: Asymmetry* **1996**, 7, 1847-1882.

Y. Chai, S.-P. Hong, H. A. Lindsay, C. McFarland, M. C. McIntosh, *Tetrahedron* **2002**, 58, 2905-2928.

The aldol reaction via ester enolates – the Ireland-Claisen reaction

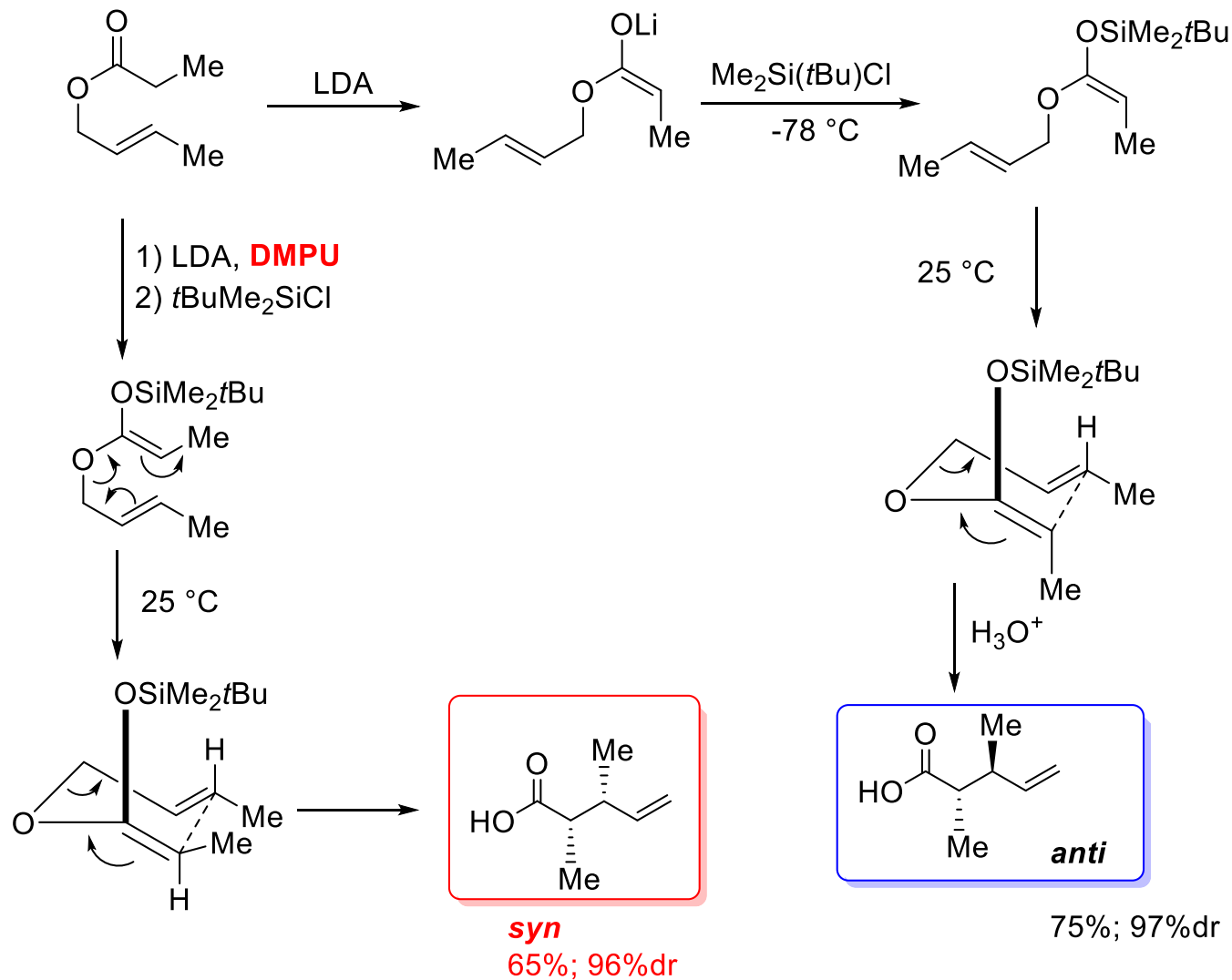

Review: D. Enders, *Tetrahedron: Asymmetry* **1996**, 7, 1847-1882.

Y. Chai, *Tetrahedron* **2002**, 58, 2905-2928.

The aldol reaction via ester enolates – the Ireland-Claisen reaction

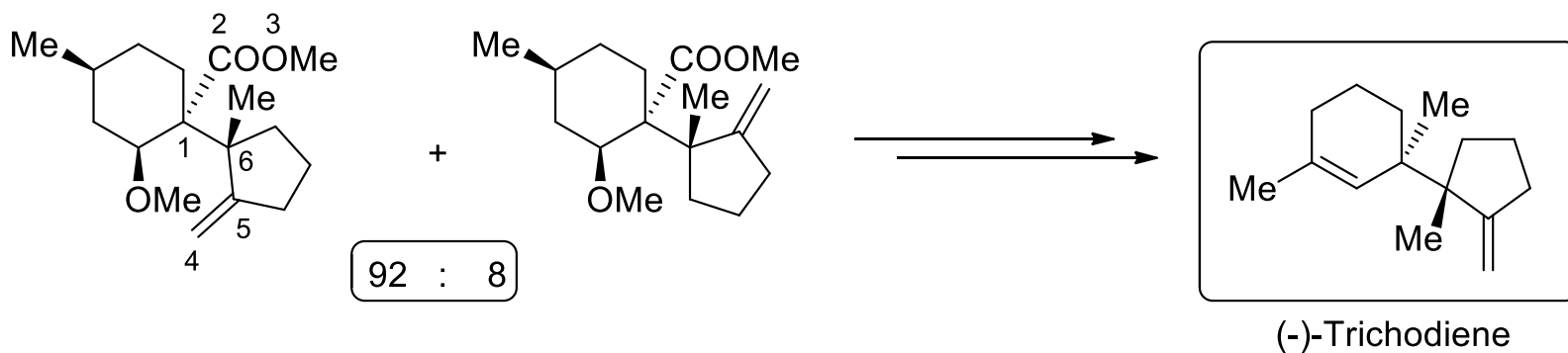
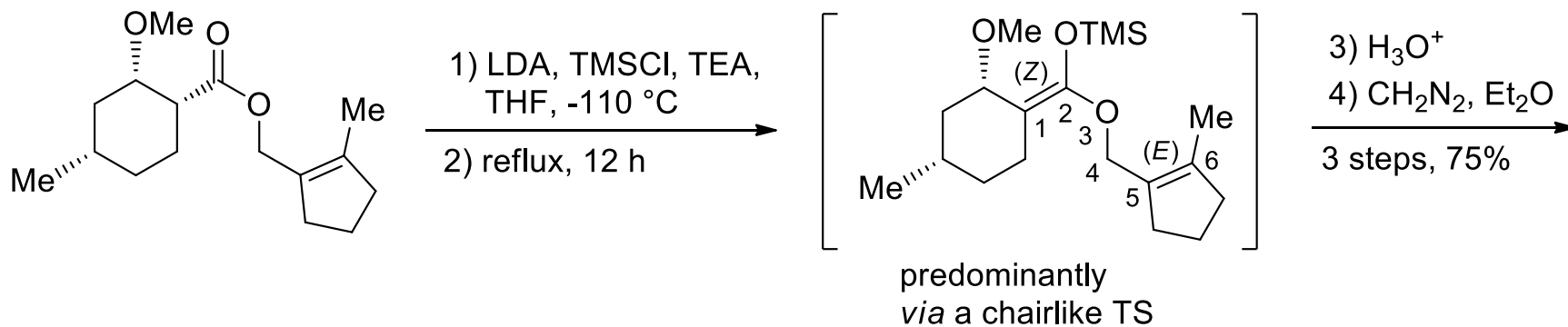

J. C. Gilbert, R. D. Selliah, *J. Org. Chem.* **1993**, *58*, 6255-6265.

Alternative synthesis of aldol products

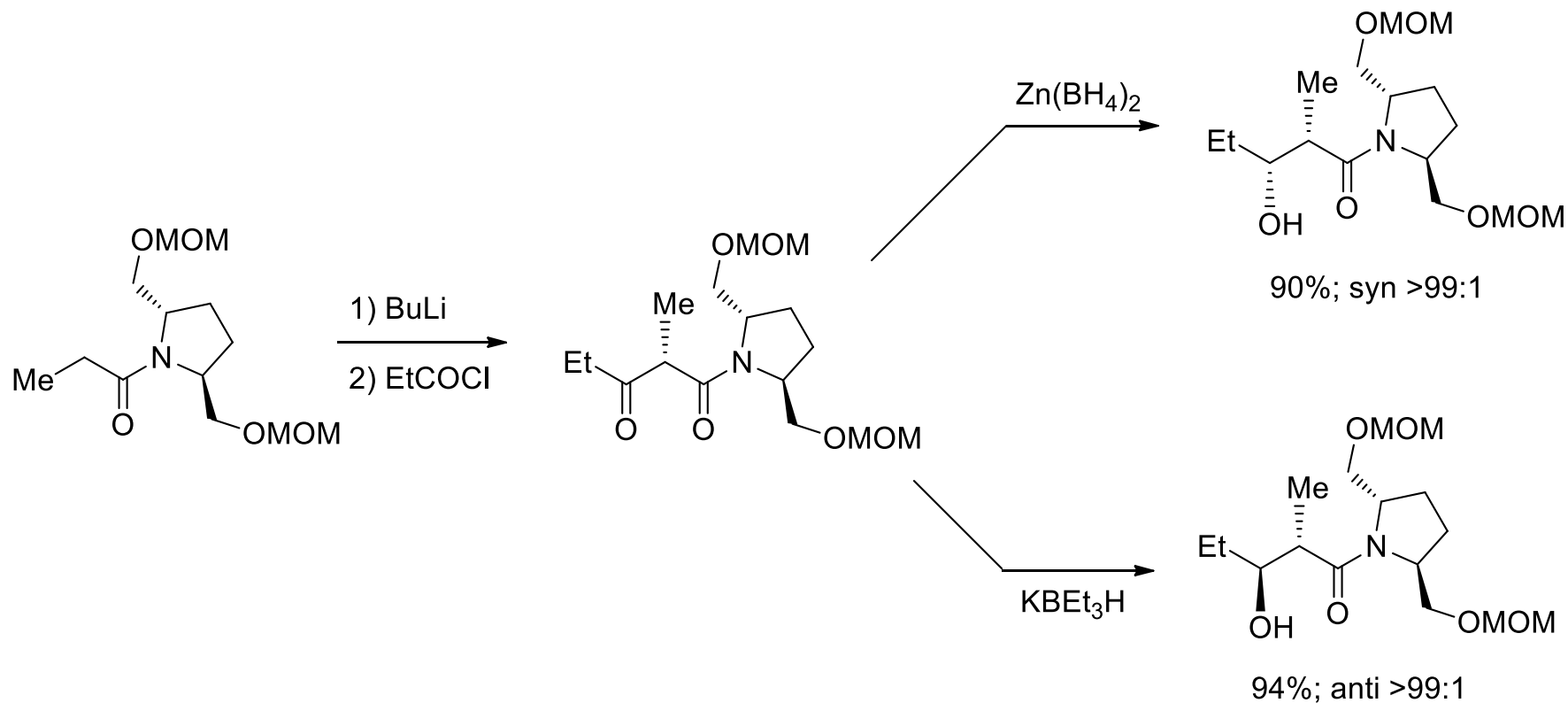

Y. Ito, T. Katsuki, M. Yamaguchi, *Tetrahedron Lett.* **1985**, 26, 4643.

Asymmetric catalysis – Asymmetric oxidations

The Sharpless oxidation

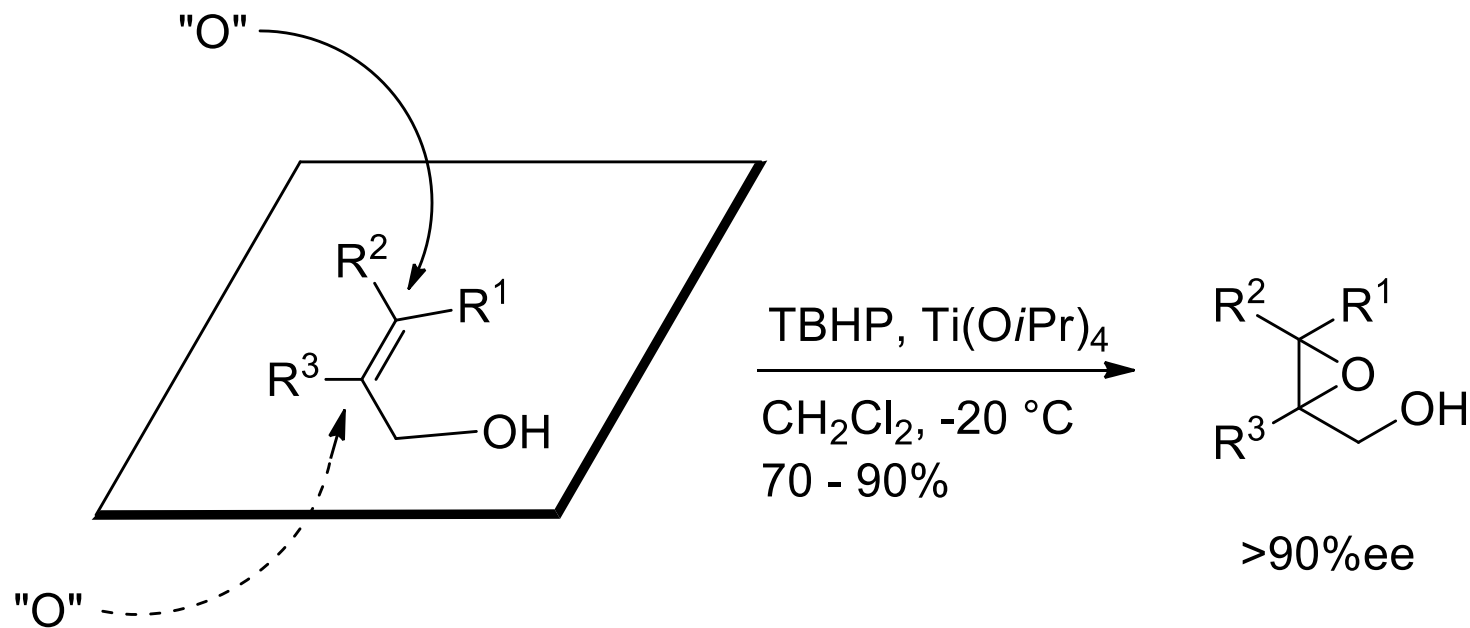

(R,R)-L-(+)-tartrate (natural)

T. Katsuki, K. B. Sharpless, *J. Am. Chem. Soc.* **1980**, 102, 5974.

Kinetic resolution of secondary alcohols

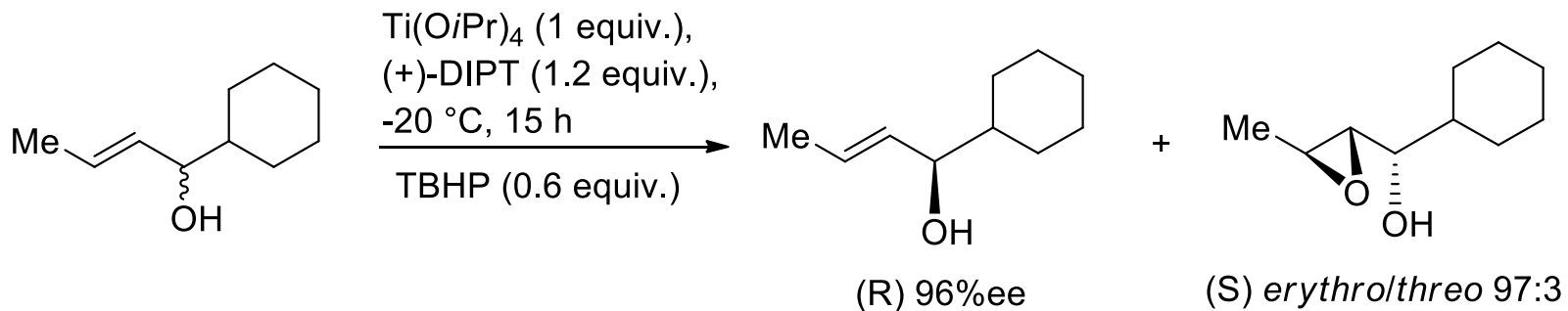
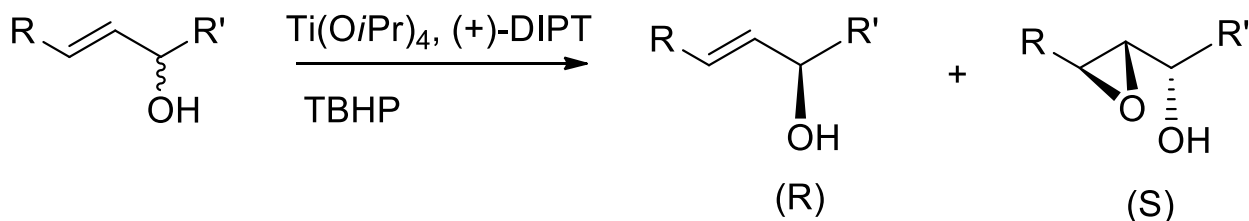
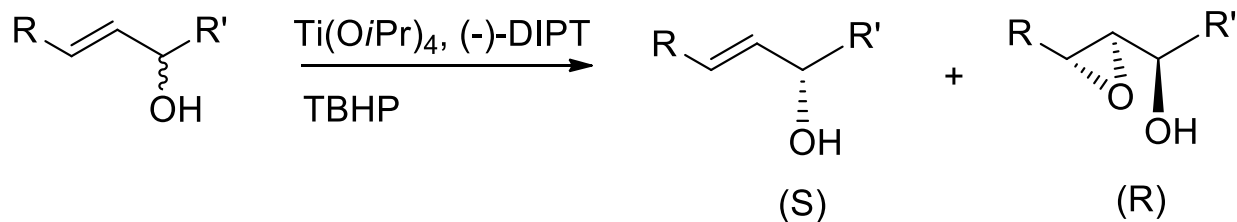

V. S. Martin, S. S. Woodard, T. Katsuki, Y. Yamada, M. Ikeda, K. B. Sharpless,
J. Am. Chem. Soc. **1981**, *103*, 6237.

Matched and mismatched cases

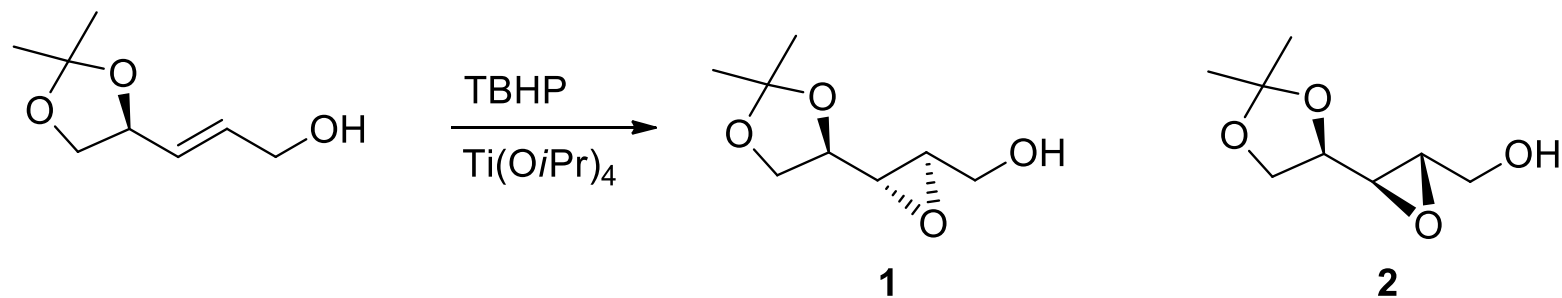
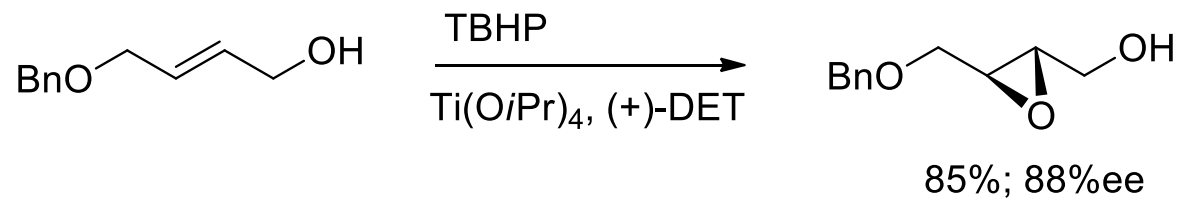

in the absence of tartrate:	1 : 2 = 2.3 : 1
in the presence of (+)-DET, mismatched	1 : 2 = 1 : 22
in the presence of (-)-DET, matched	1 : 2 = 90 : 1

S. Takano, K. Samizu, T. Sugihara, K. Ogasawara, *J. Chem. Soc., Chem. Commun.* **1989**, 1344.

Mechanism of Ti-catalyzed Sharpless epoxidation

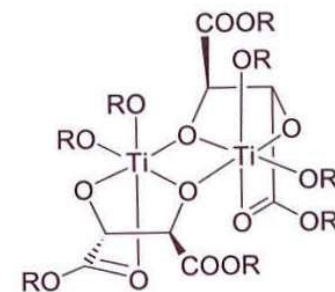
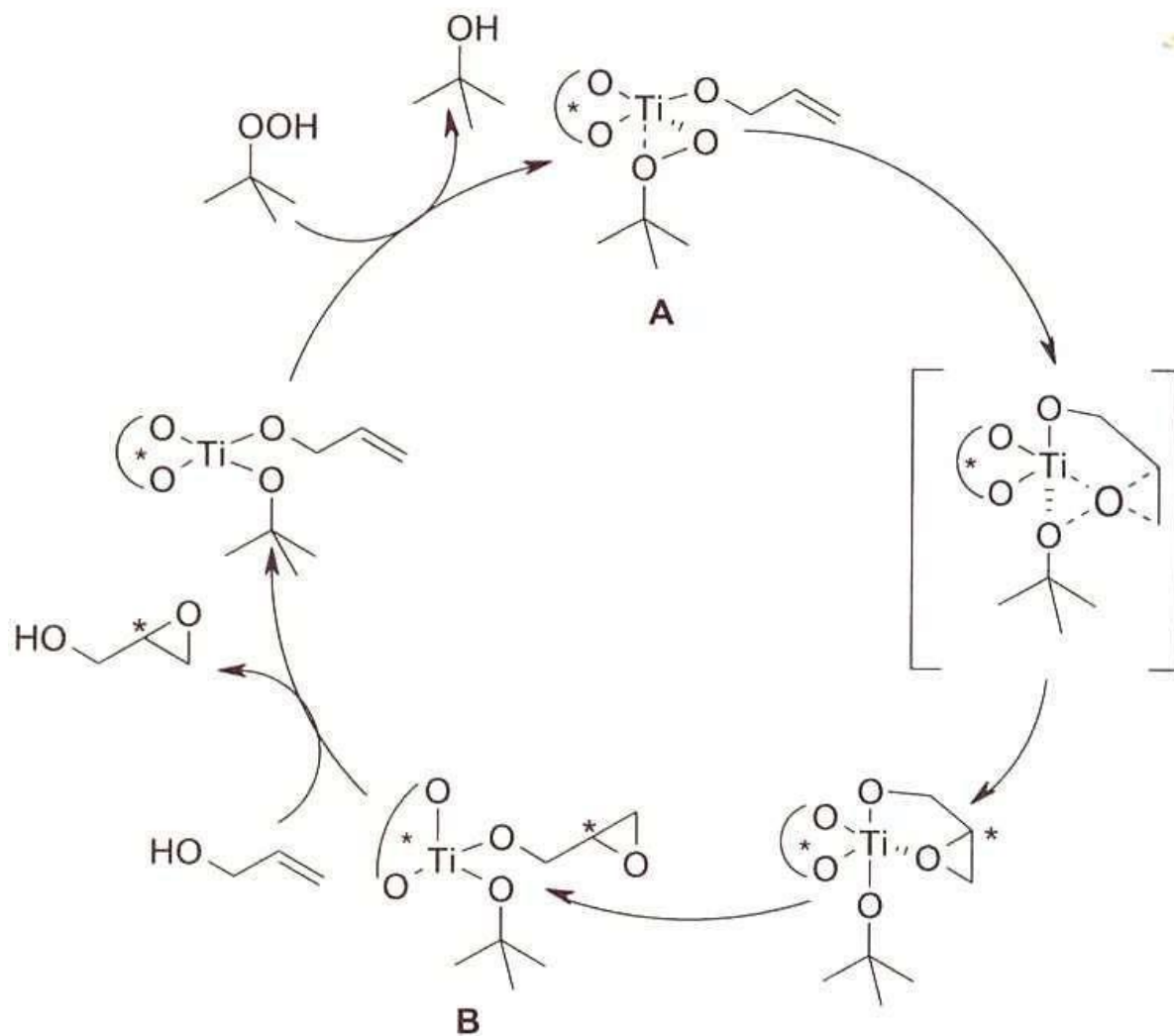

Structure of dinuclear Ti-tartrate complexes.

Synthetic applications of the Sharpless epoxidation

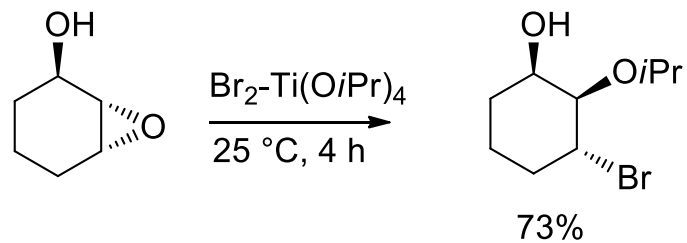
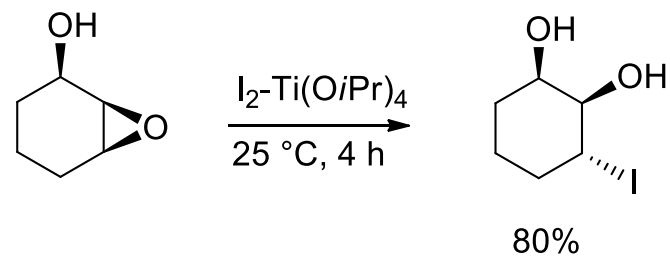
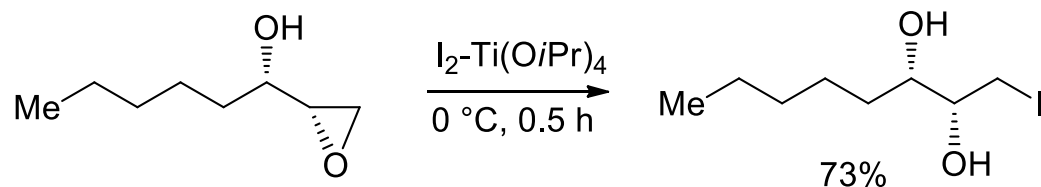
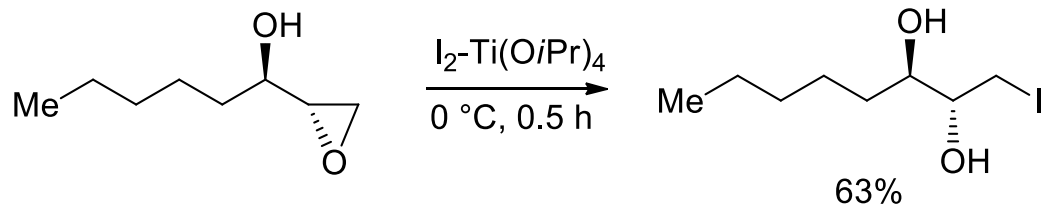

E. Alvarez, M. T. Nunez, V. S. Martin, *J. Org. Chem.* **1990**, 55, 3429.

Ring opening with cuprates

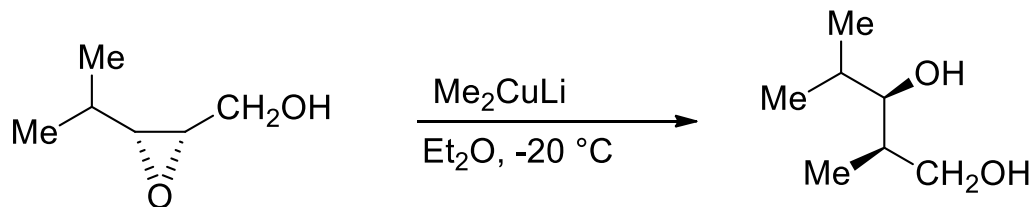
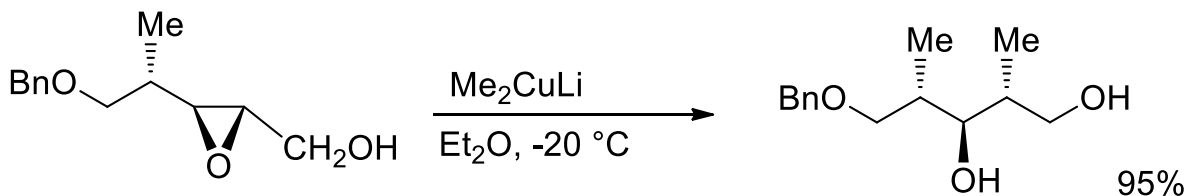
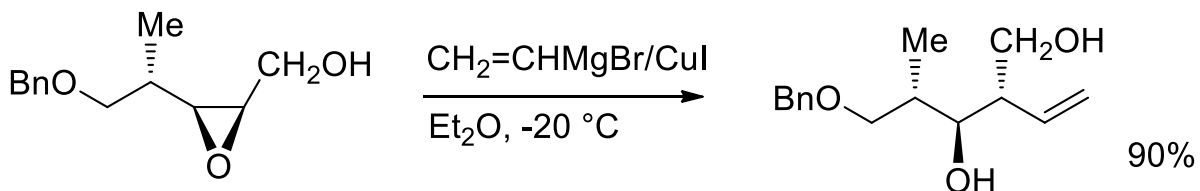
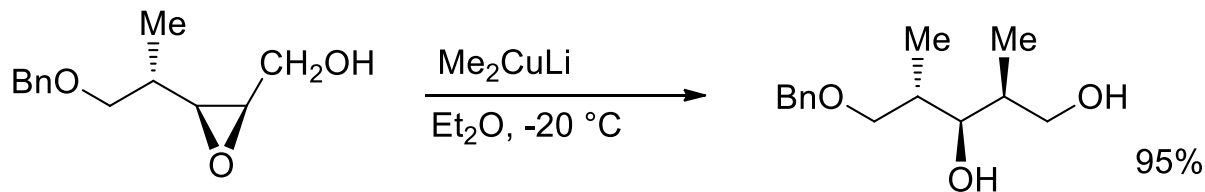

M. R. Johnson, T. Nakata, Y. Kishi, *Tetrahedron Lett.* **1979**, 20, 4343.

R. D. Wood, B. Ganem, *Tetrahedron Lett.* **1982**, 23, 707.

Desymmetrization of meso-epoxides

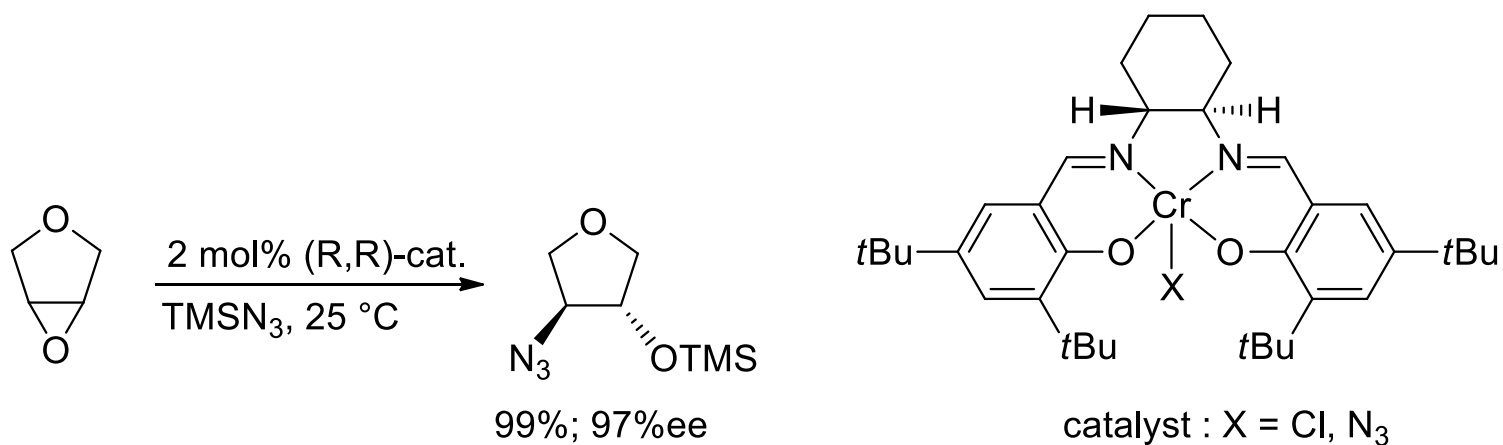
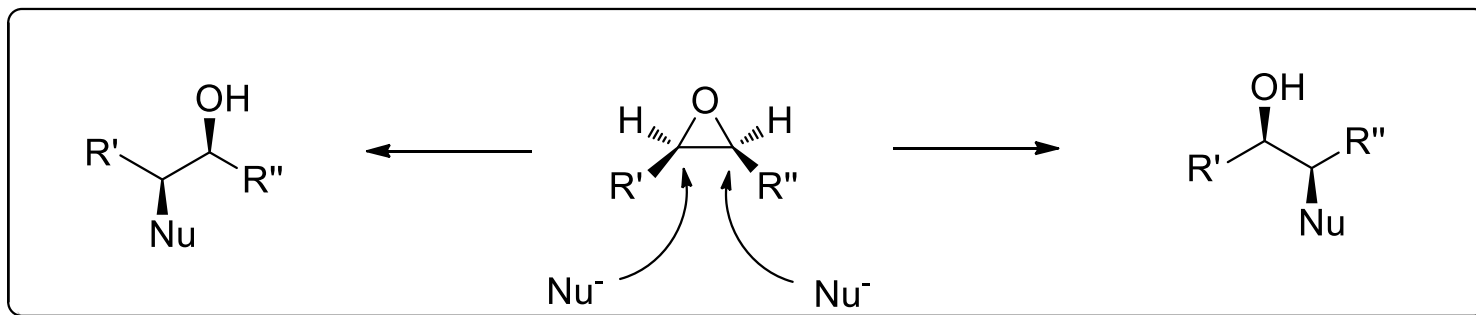

S. E. Schaus, J. F. Larrow, E. N. Jacobsen, *J. Org. Chem.* **1997**, 62, 4197.

Desymmetrization of meso-epoxides

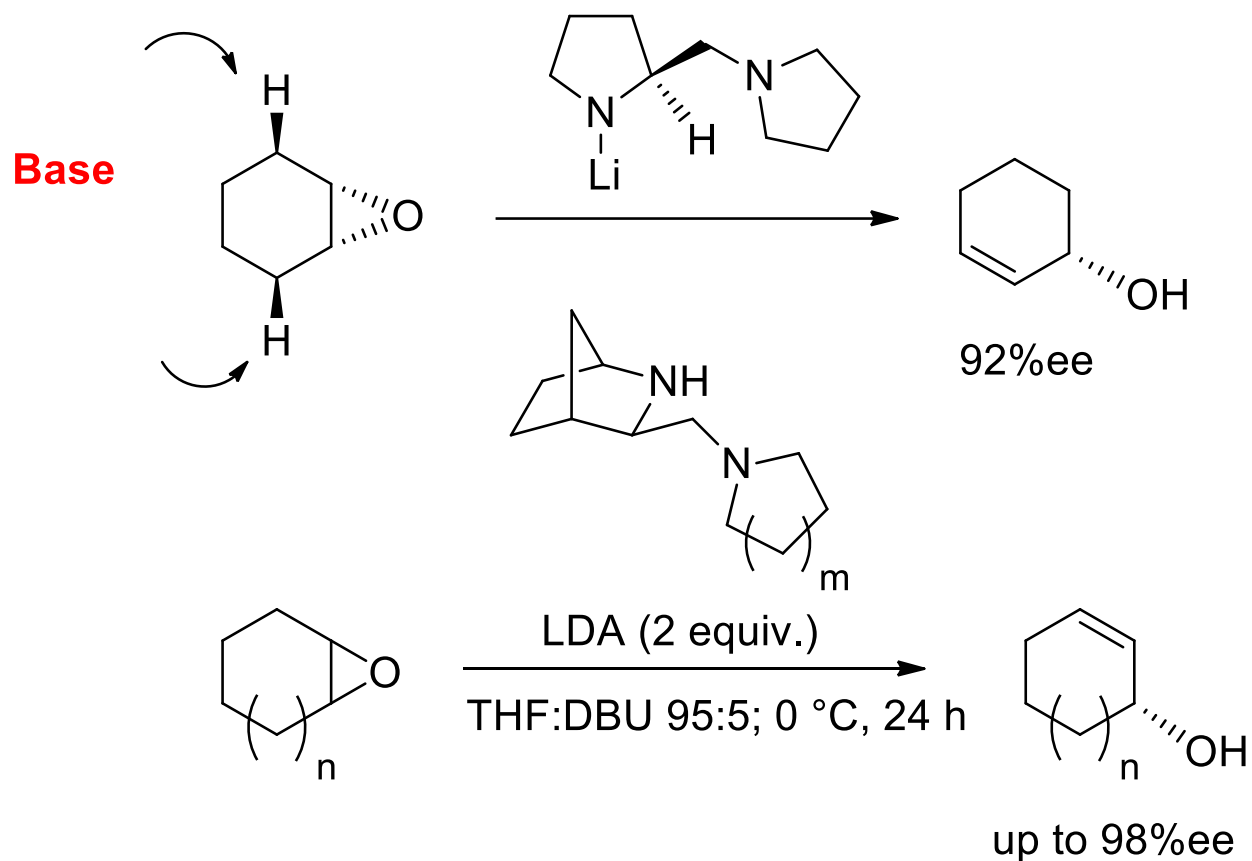

I. Paterson, D. J. Berrisford, *Angew. Chem. Int. Ed.* **1992**, 31, 1179.

M. J. Södergren, P. G. Andersson, *J. Am. Chem. Soc.* **1998**, 120, 10760.

Asymmetric dihydroxylation

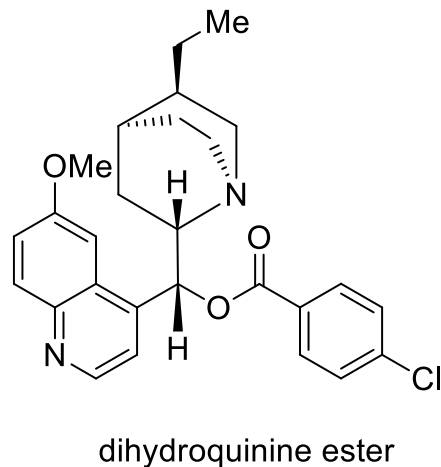
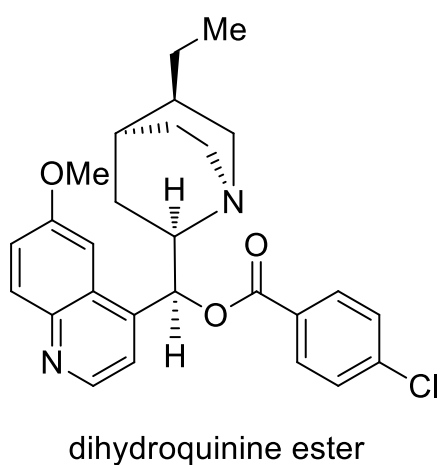
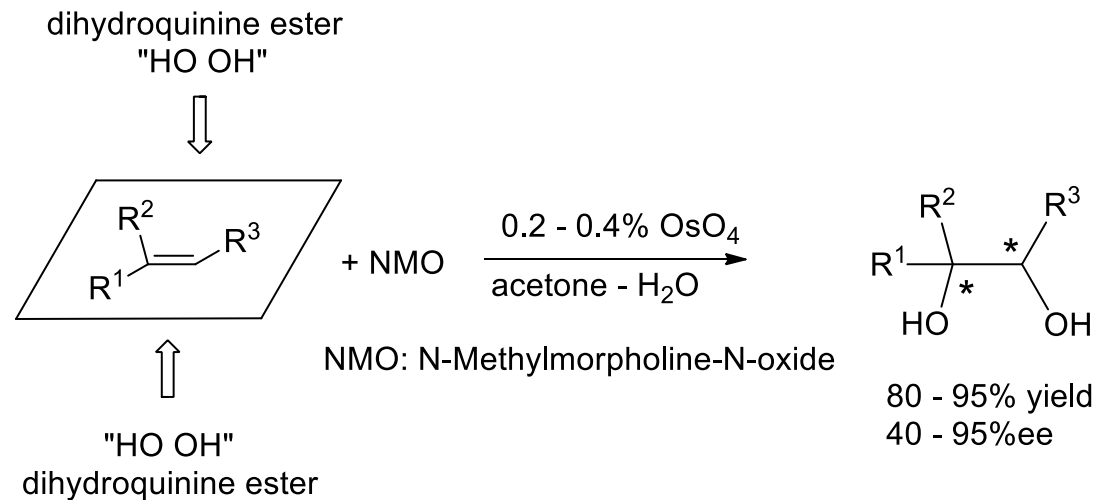

A. E. Jacobsen, I. Markó, W. S. Mungall, G. Schröder, K. B. Sharpless, *J. Am. Chem. Soc.* **1988**, *110*, 1968.

A. E. Jacobsen, I. Markó, M. B. France, J. S. Svendsen, K. B. Sharpless, *J. Am. Chem. Soc.* **1989**, *111*, 737.

J. S. M. Wai, I. Markó, J. S. Svendsen, M. G. Finn, A. E. Jacobsen, K. B. Sharpless, *J. Am. Chem. Soc.* **1989**, *111*, 1123.

Asymmetric dihydroxylation leading to (2S)-propranolol

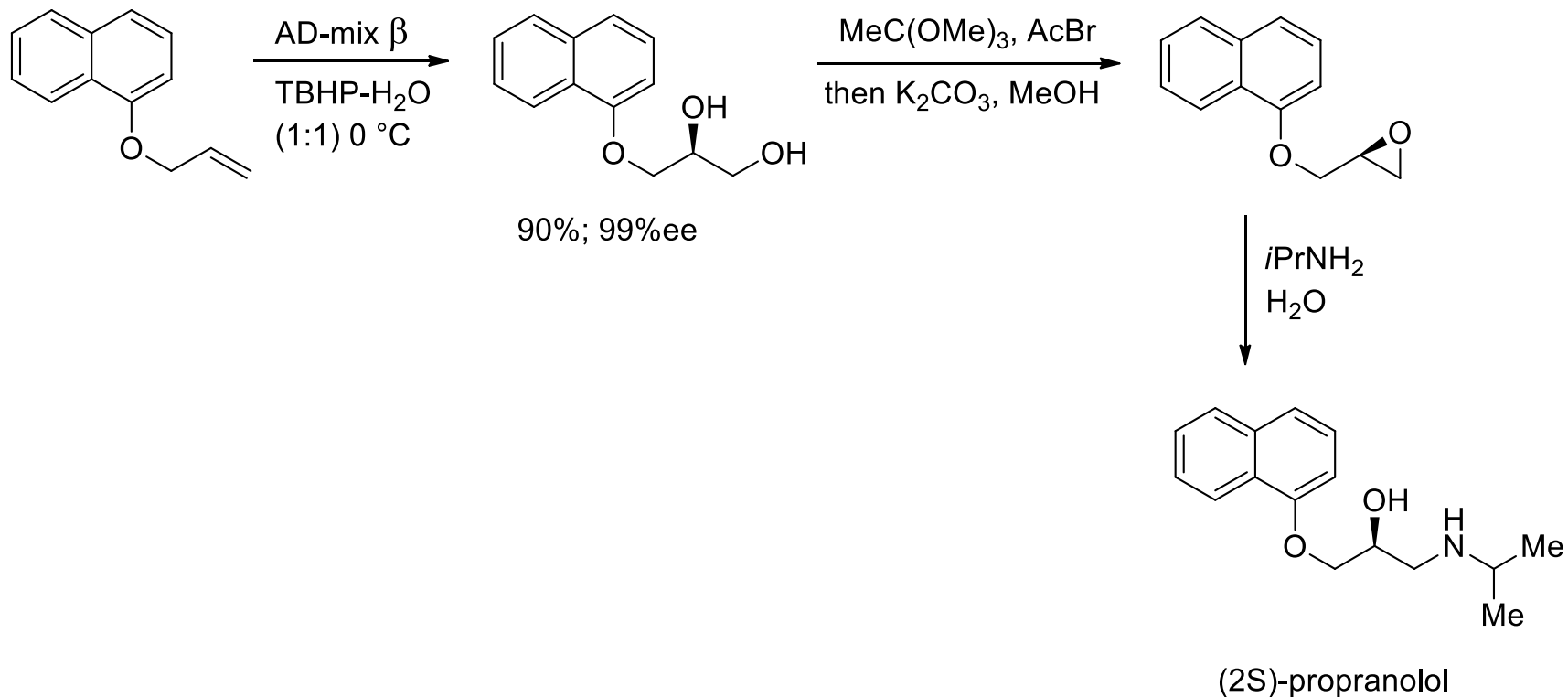

Z. Wang, X. Zhang, K. B. Sharpless, *Tetrahedron Lett.* **1993**, 34, 2267.

Asymmetric aminohydroxylation

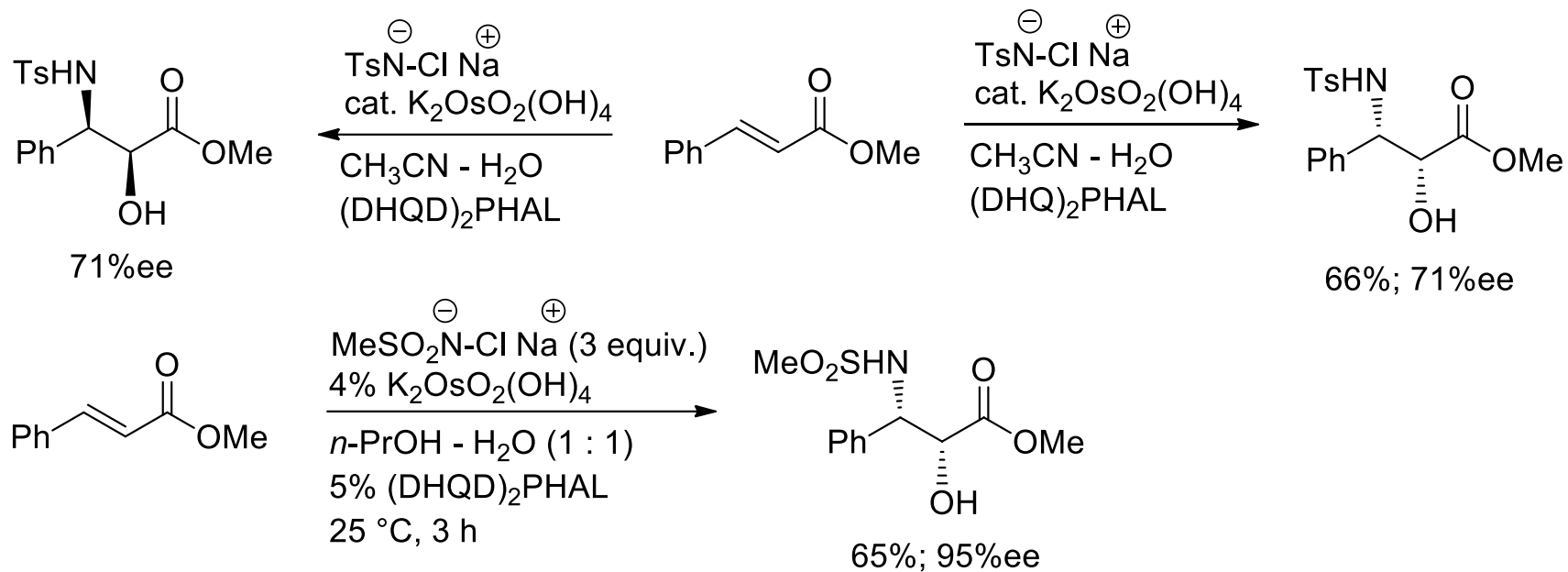

G. Li, H. T. Chang, K. B. Sharpless, *Angew. Chem. Int. Ed.* **1996**, 35, 451.
O. Reiser, *Angew. Chem. Int. Ed.* **1996**, 35, 1308.

Epoxidation of non-functionalized epoxides

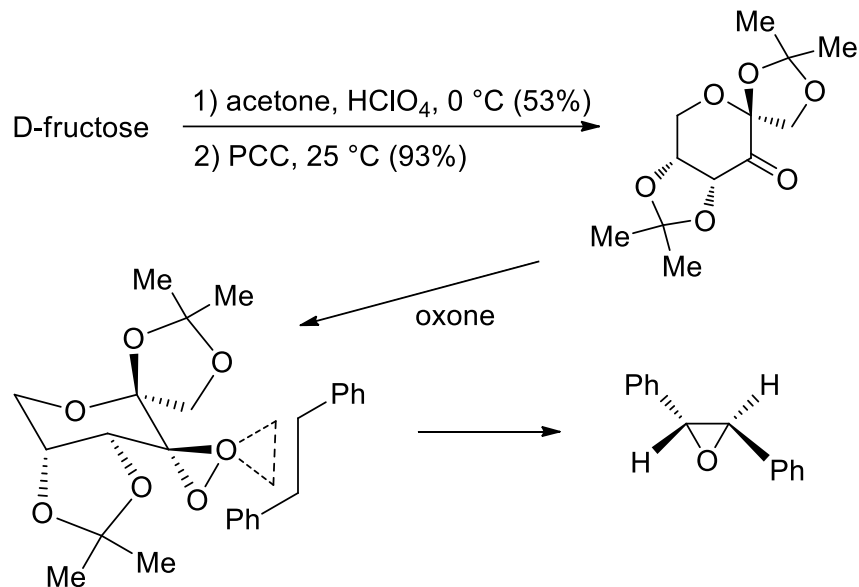

Y. Tu, Z. Wang, Y. Shi, *J. Am. Chem. Soc.* **1996**, *118*, 9806.

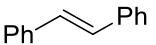
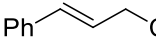
Substrate	Yield (%)	ee(%)	config.
	73	>95	<i>R, R</i>
	81	88	<i>R, R</i>
	61	93	<i>2S, 3R</i>
	73	92	<i>R, R</i>
	69	91	<i>R, R</i>

Epoxidation of non-functionalized epoxides

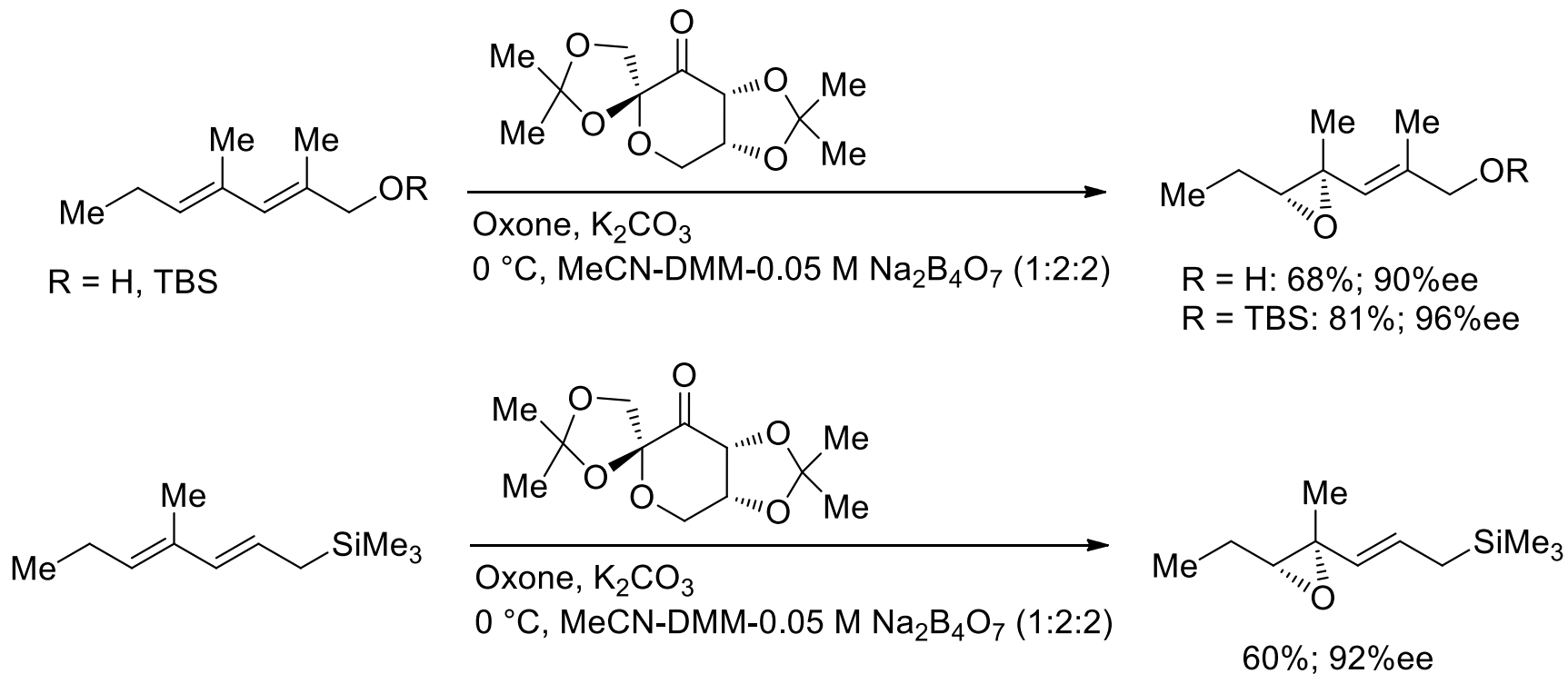

M. Frohn, M. Dalkiewicz, Y. Tu, Z.-X. Wang, Y. Shi, *J. Org. Chem.* **1998**, 63, 2948.

Ligands for asymmetric hydrogenation

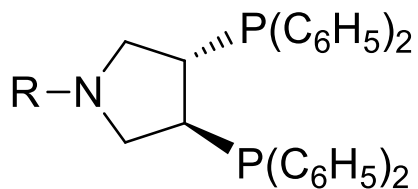

DeguPhos

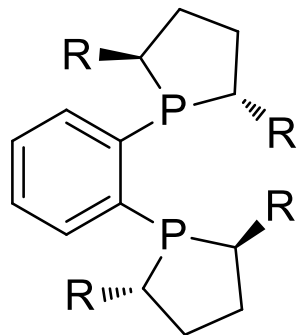

DuPhos

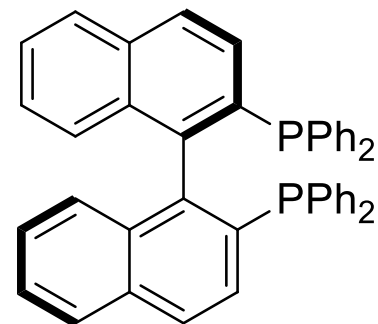

(R)-BINAP

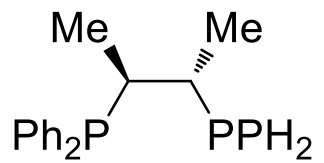

(S,S)-ChiraPhos

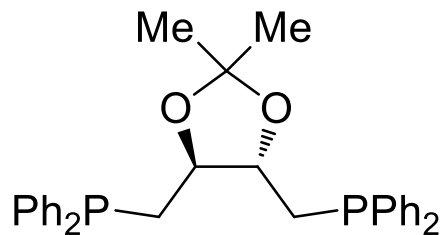

DIOP

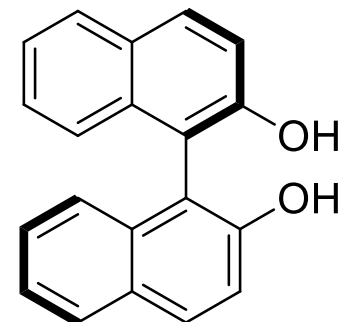

(R)-BINOL

Catalytic hydrogenation of enamides

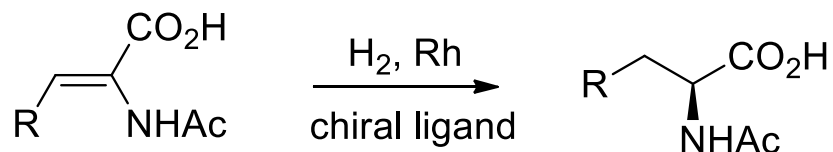

Phosphine ligand	product ee (%)	
	R = C ₆ H ₅	R = H
(<i>R,R</i>)-DIPAMP	96 (<i>S</i>)	94 (<i>S</i>)
(<i>S,S</i>)-ChiraPhos	99 (<i>R</i>)	91 (<i>R</i>)
(<i>S,S</i>)-NorPhos	95 (<i>S</i>)	90 (<i>R</i>)
(<i>R,R</i>)-DIOP	85 (<i>R</i>)	73 (<i>R</i>)
(<i>S,S</i>)-BPPM	91 (<i>R</i>)	98.5 (<i>R</i>) ^a
(<i>S</i>)-BINAP	100 (<i>R</i>) ^a	98 (<i>R</i>)
(<i>S</i>)-(<i>R</i>)-BPPFA	93 (<i>S</i>)	
(<i>S,S</i>)-SkewPhos	92 (<i>R</i>)	
(<i>S,S</i>)-CycPhos	88 (<i>R</i>)	
(<i>S,S</i>)-Et-DuPhos	99 (<i>S</i>)	99.4 (<i>S</i>)

^a hydrogenation of the N-benzoyl derivative

K. E. Koenig "Asymmetric Hydrogenation of Prochiral Olefins" in *Catalysis of Organic Reactions*, Marcel Dekker, New York, **1984**, Chap. 3.

Ru-catalyzed hydrogenations

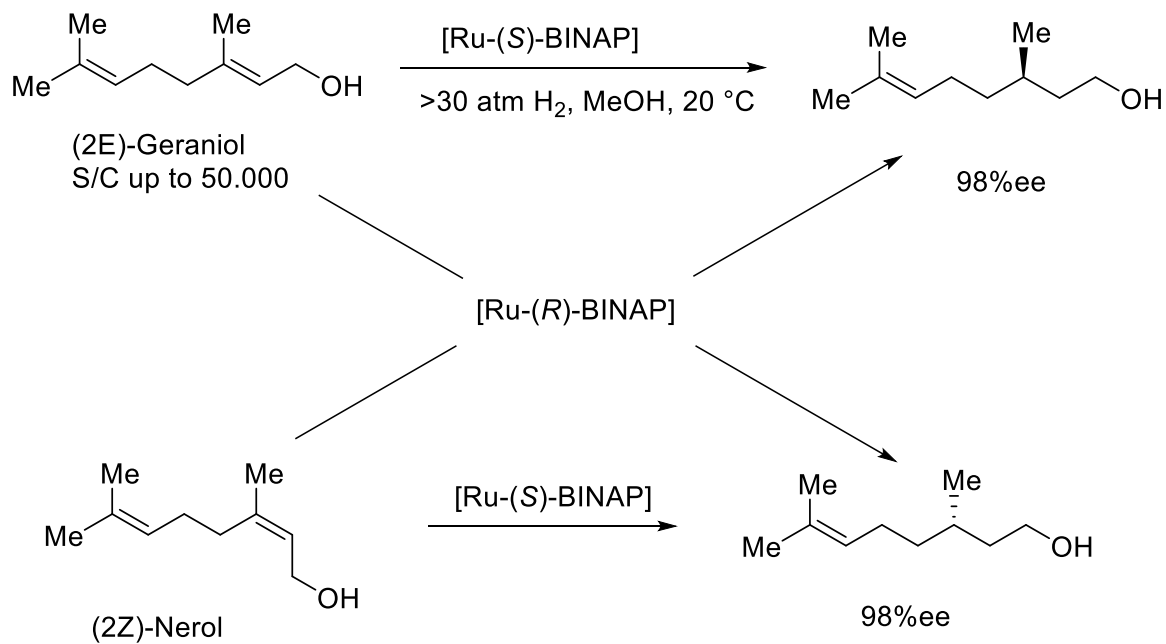
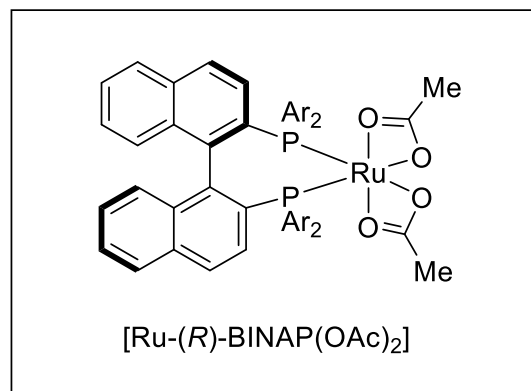

H. Takaya, T. Ohta, N. Sayo, H. Kumobayashi, S. Akutagawa, S. Inoue, R. Noyori, *J. Am. Chem. Soc.* **1987**, *109*, 1596.

Rh-catalyzed hydrogenations

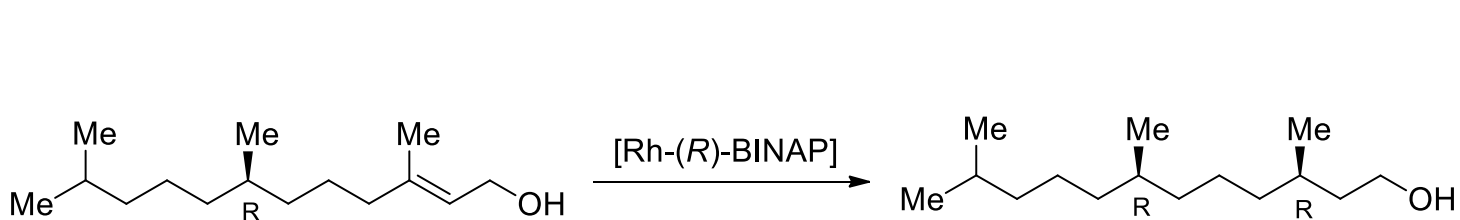
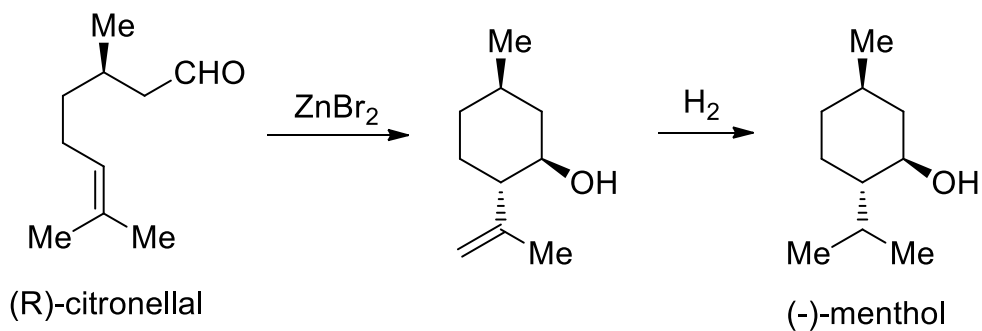
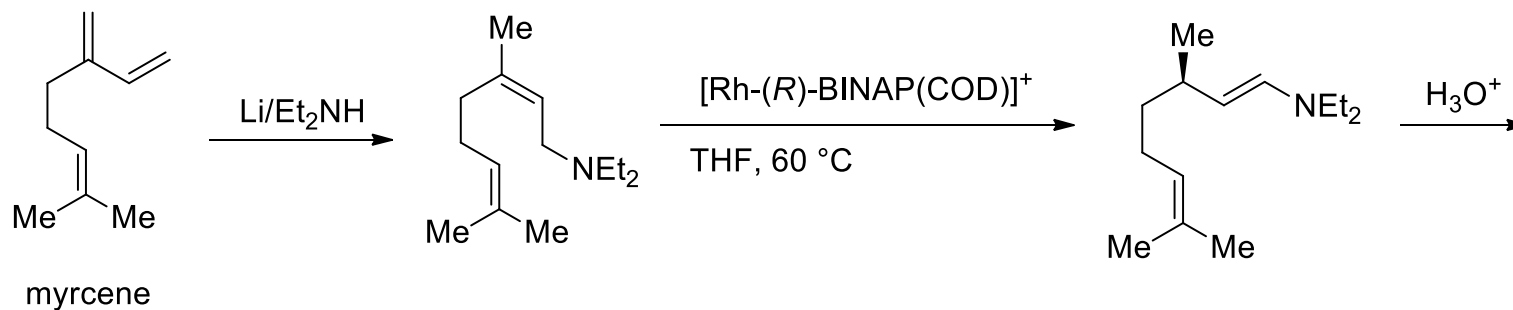

R. Noyori, *Asymmetric Catalysis in Organic Synthesis*, John Wiley & Sons, Inc., New York, **1994**, Chap. 3.

Asymmetric hydrogenation of carbonyl compounds

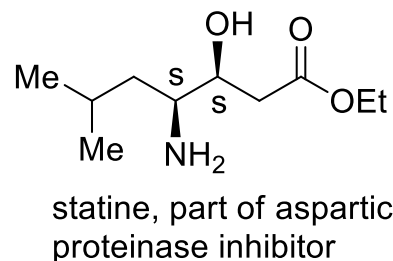
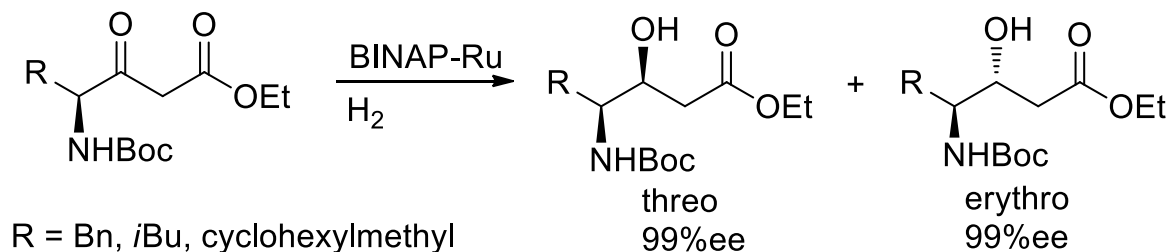

T. Nishi, M. Kitamura, T. Ohkuma, R. Noyori, *Tetrahedron Lett.* **1988**, 29, 6327.

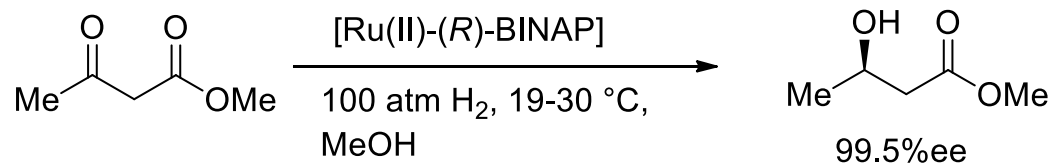
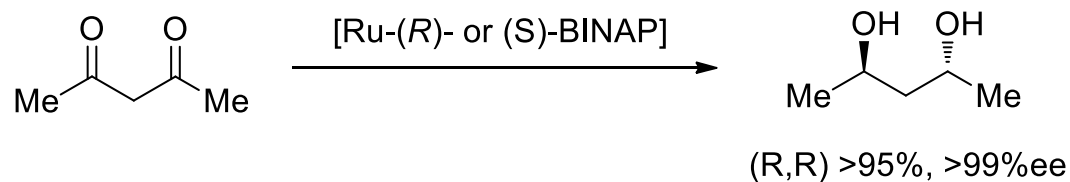

Q. Fan, C. H. Yeung, A. S. C. Chan, *Tetrahedron Asymmetry* **1997**, 8, 4041.

The oxazaborolidine catalyst system

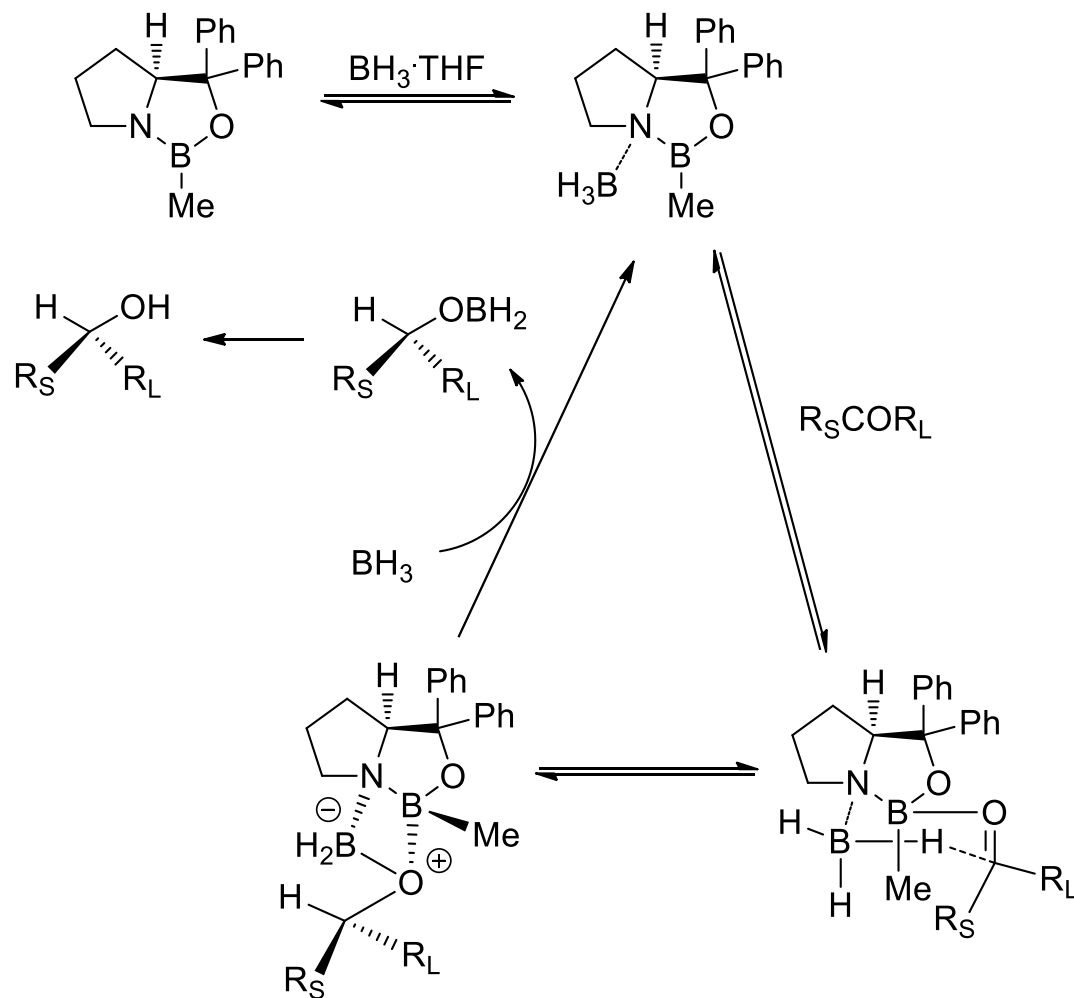

E. J. Corey, R. K. Bakshi, S. Shibata, *J. Am. Chem. Soc.* **1987**, *109*, 5551.

E. J. Corey, J. O. Link, *Tetrahedron Lett.* **1992**, *33*, 4141.

V. Nevalainen, *Tetrahedron Asymmetry* **1991**, *2*, 1133.

E. J. Corey, J. O. Link, S. Sarshar, Y. Shao, *Tetrahedron Lett.* **1992**, *33*, 7103.

The oxazaborolidine catalyst system

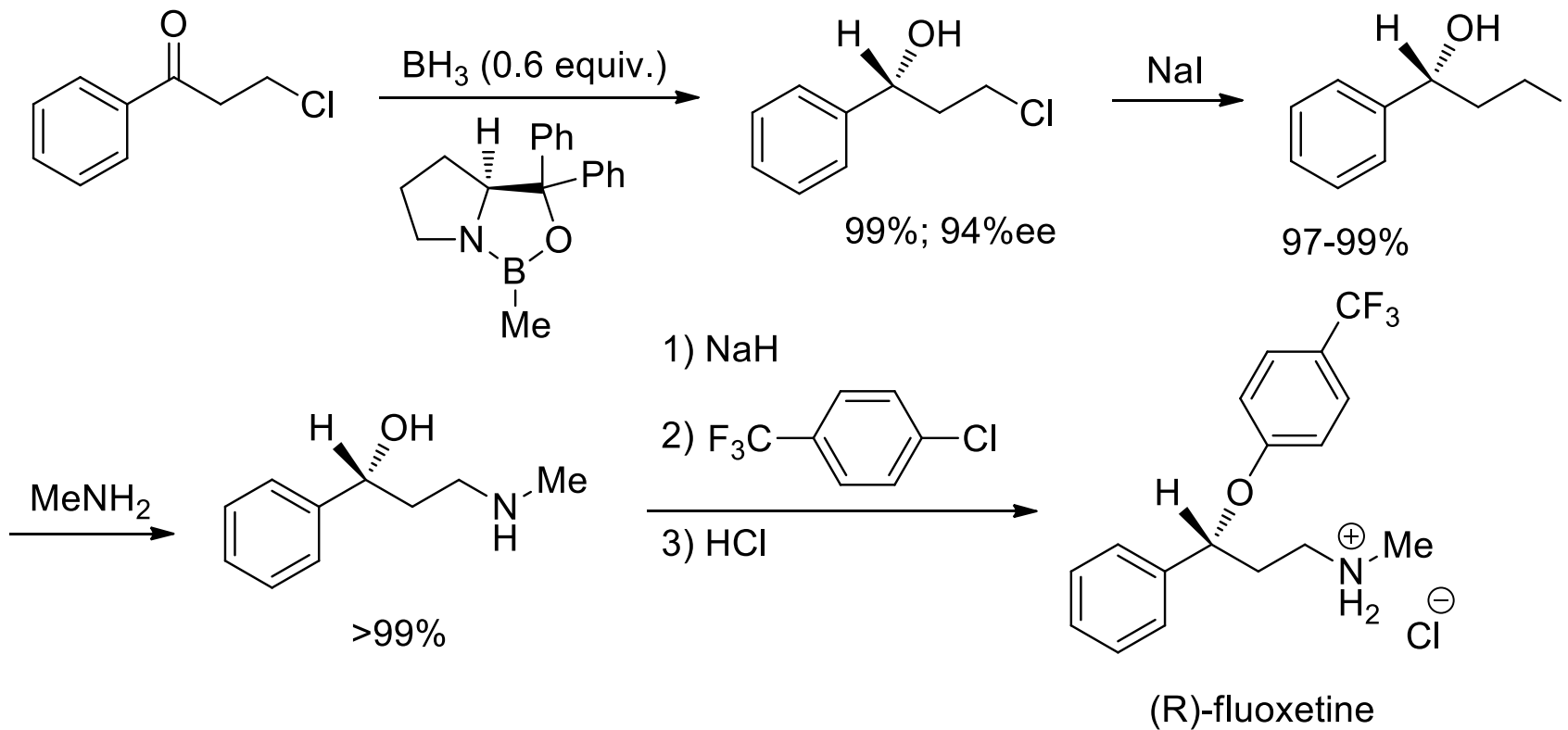

E. J. Corey, G. A. Reichard, *Tetrahedron Lett.* **1989**, 30, 5207.

CBS-Reduction

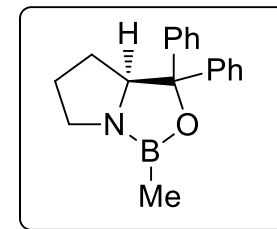
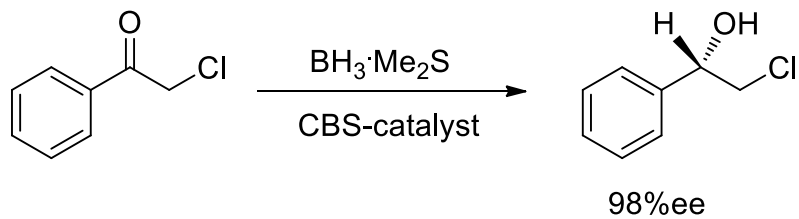

CBS-catalyst

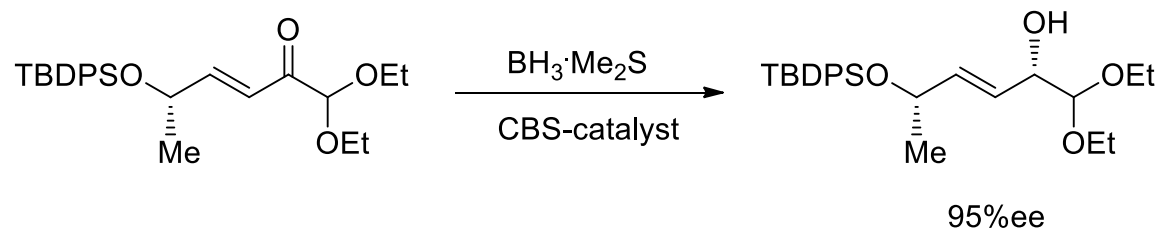
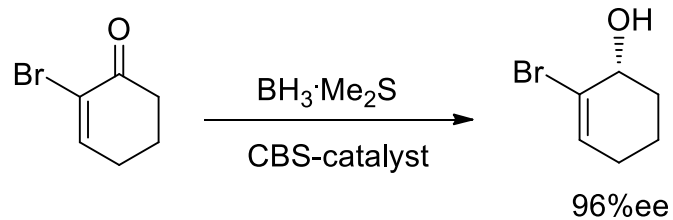
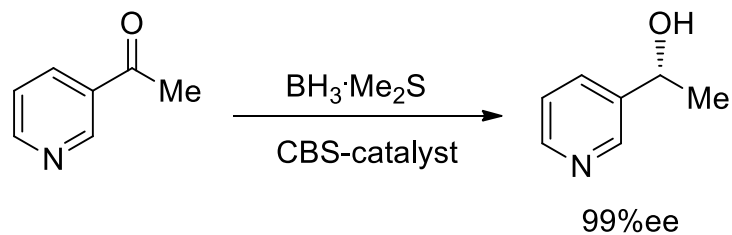

Review: E. J. Corey, C. J. Helal, *Angew. Chem. Int. Ed.* **1998**, 37, 1986-2012.

CBS-Reduction

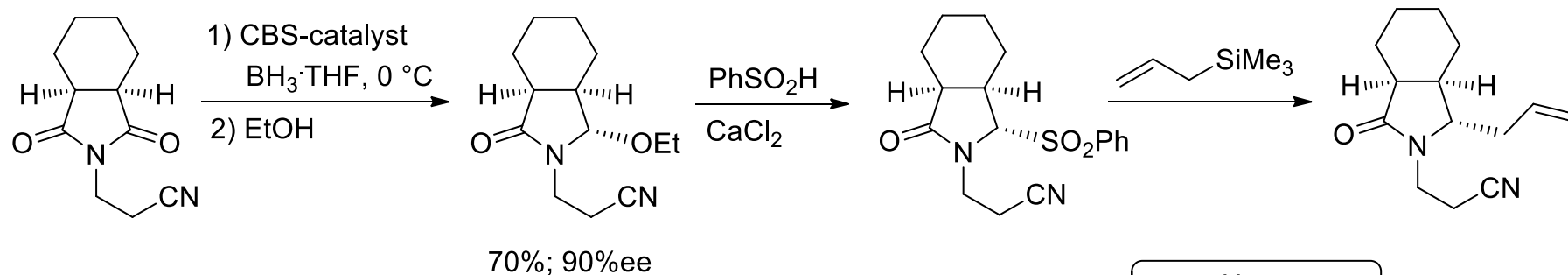

H. Hiemstra, *Tetrahedron: Asymmetry* **1997**, 8, 1773.
Tetrahedron Lett. **1994**, 35, 1087.

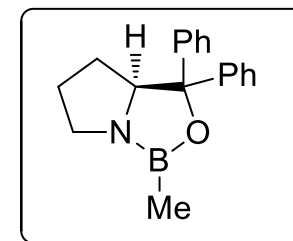

Asymmetric transfer hydrogenation

Meerwein-Ponndorf-Verley reaction

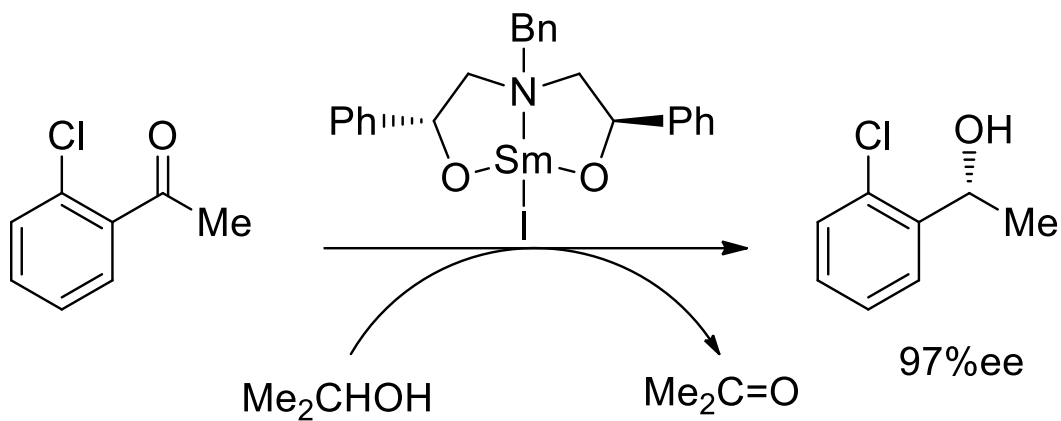

D. A. Evans, S. G. Nelson, M. R. Gagne, A. R. Muci, *J. Am. Chem. Soc.* **1993**, *115*, 9800.

Enantioselective imine hydrogenation

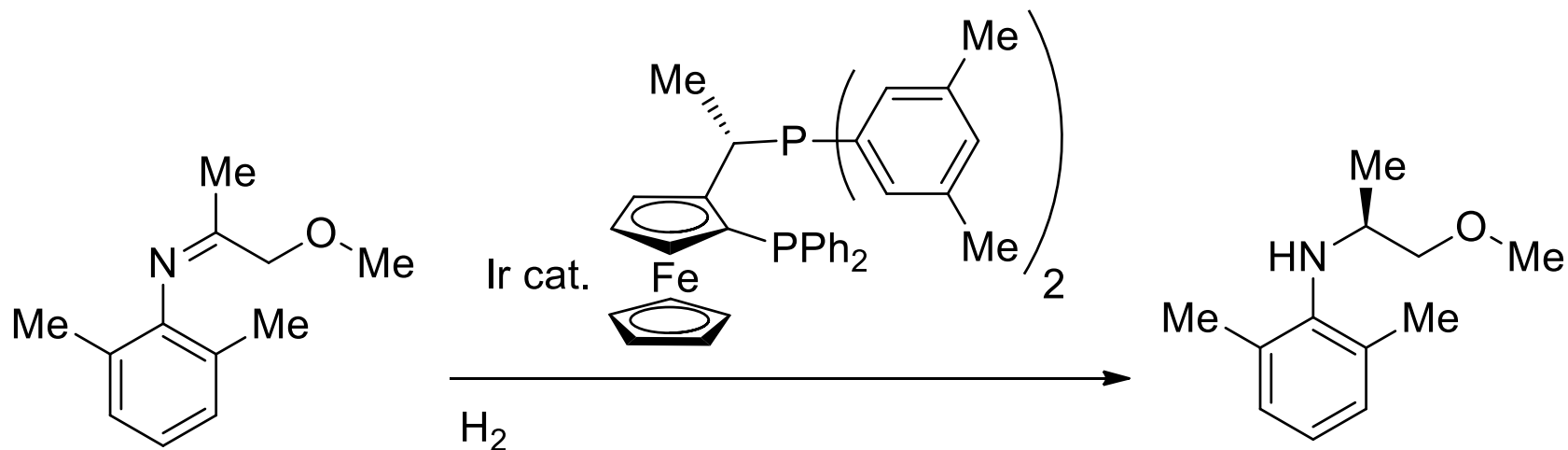

substrat / Ir < 100.000;
TOF > 10.000 h⁻¹

80%ee

A. Togni, *Angew. Chem.* **1996**, 108, 1581.

F. Spindler, *Chimia*, **1997**, 6, 297, Patent LONZA AG

Asymmetric Diels-Alder reaction

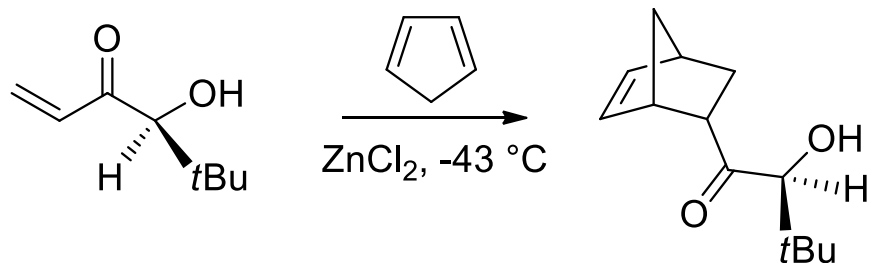

endo/exo = 15 : 1
de > 100 for *endo*

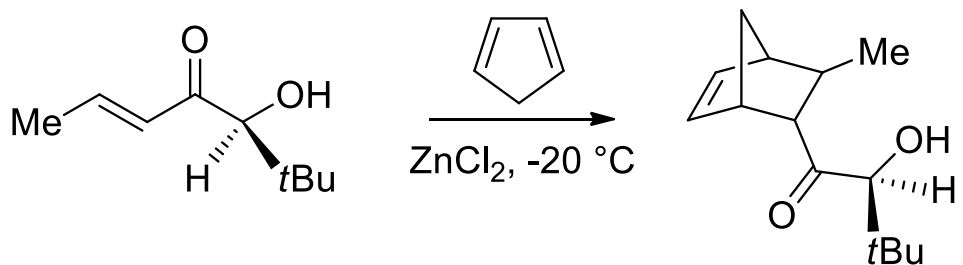

endo/exo = 15 : 1
de > 100 for *endo*

S. Masamune, L. A. Reed, J. T. Davis, W. J. Choy, *J. Org. Chem.* **1983**, 48, 4441.
W. J. Choy, L. A. Reed, S. Masamune, *J. Org. Chem.* **1983**, 48, 1137.

Asymmetric Diels-Alder reaction

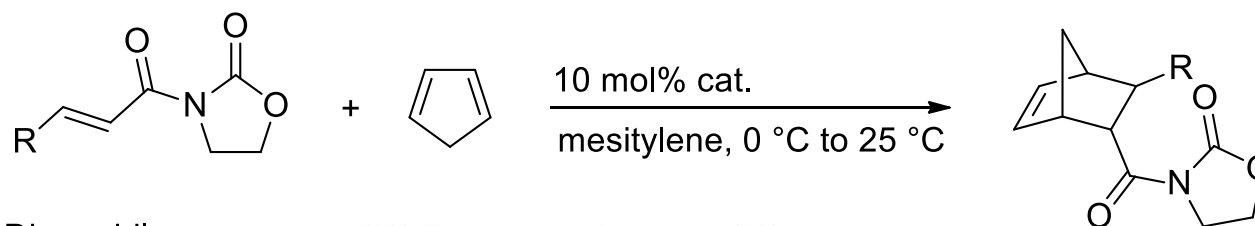
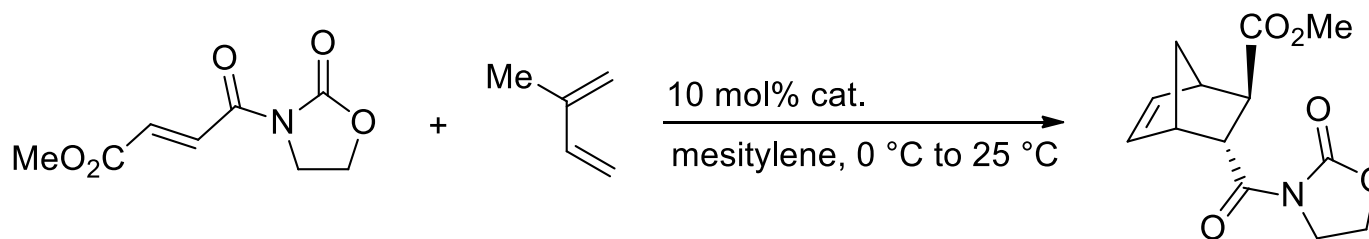
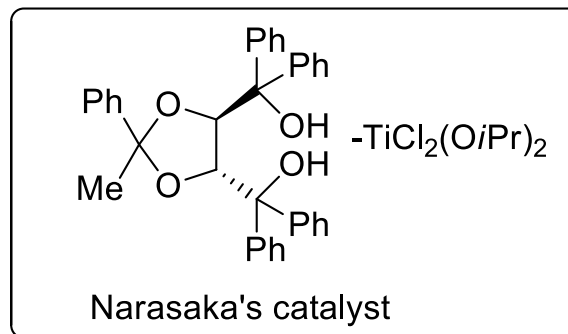

Dienophile	Yield (%) (<i>endo</i> : <i>exo</i>)	ee (%)
R = Me	90 (91 : 9)	91
R = Ph	97 (92 : 8)	82
R = <i>n</i> Pr	75 (91 : 9)	75

K. Narasaka, M. Inoue, T. Yamada, J. Sugimori, N. Iwasawa, *Chem. Lett.* **1987**, 2409.

Hetero Diels-Alder reaction

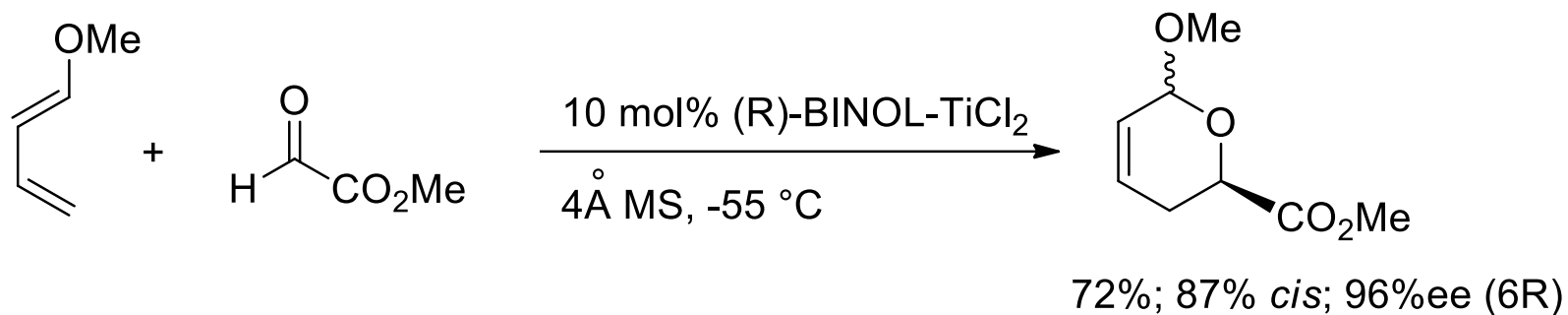

K. Mikami, Y. Motoyama, M. Terada, *J. Am. Chem. Soc.* **1994**, *116*, 2812.

M. Terada, K. Mikami, T. Nakai, *Tetrahedron Lett.* **1991**, *32*, 935.

Camphor-Derived Organocatalytic Synthesis of Chromanones

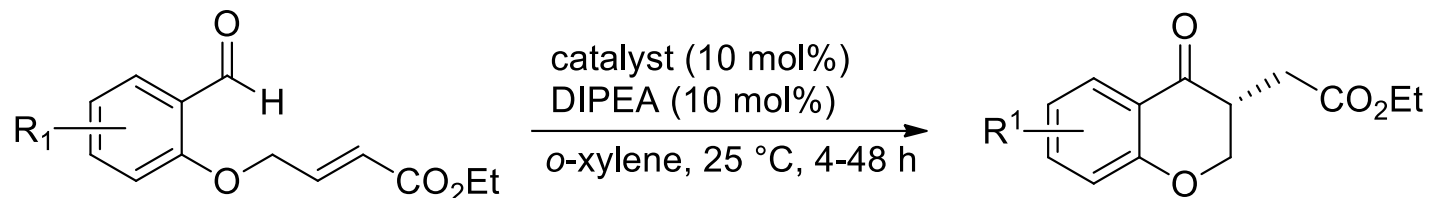

R¹ = H, 3-Me, 5-Me, 3-OMe, 4-OMe,
5-OMe, 5-Cl, 5-Br, 4-NEt₂

9 examples
89 - 97% yield
93 - 97% ee

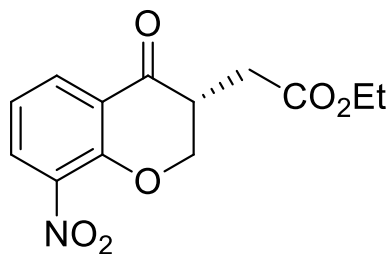
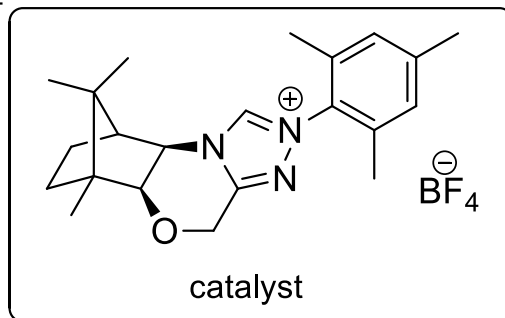

85% yield
68% ee

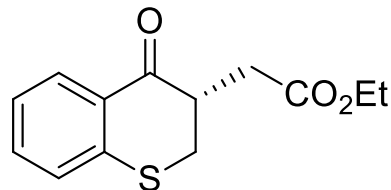

26% yield
88% ee

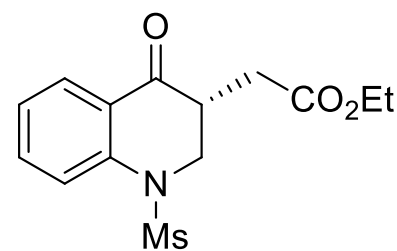

77% yield
56% ee

Asymmetric synthesis in Natural Product Chemistry

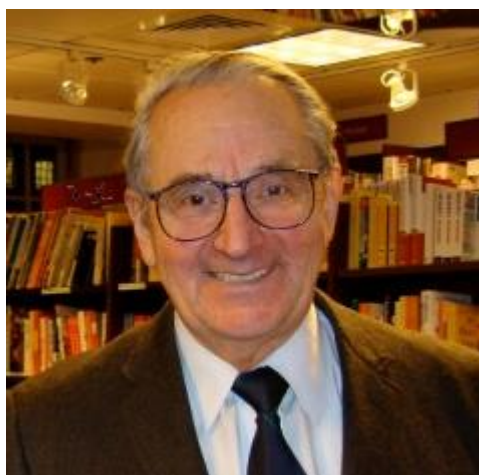

Prof. E. J. Corey

Corey's retrosynthetic analysis of aspidophytine

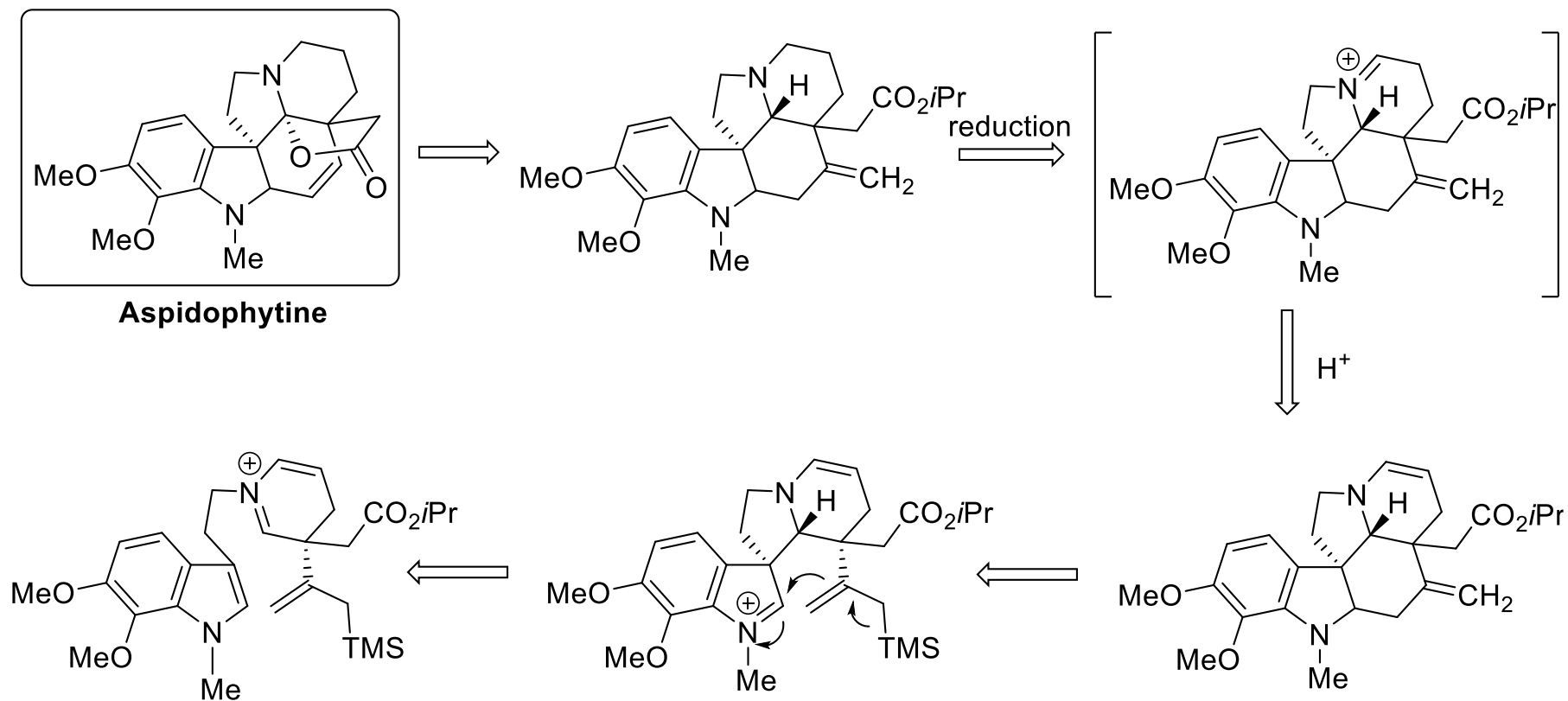

Corey's retrosynthetic analysis of aspidophytine

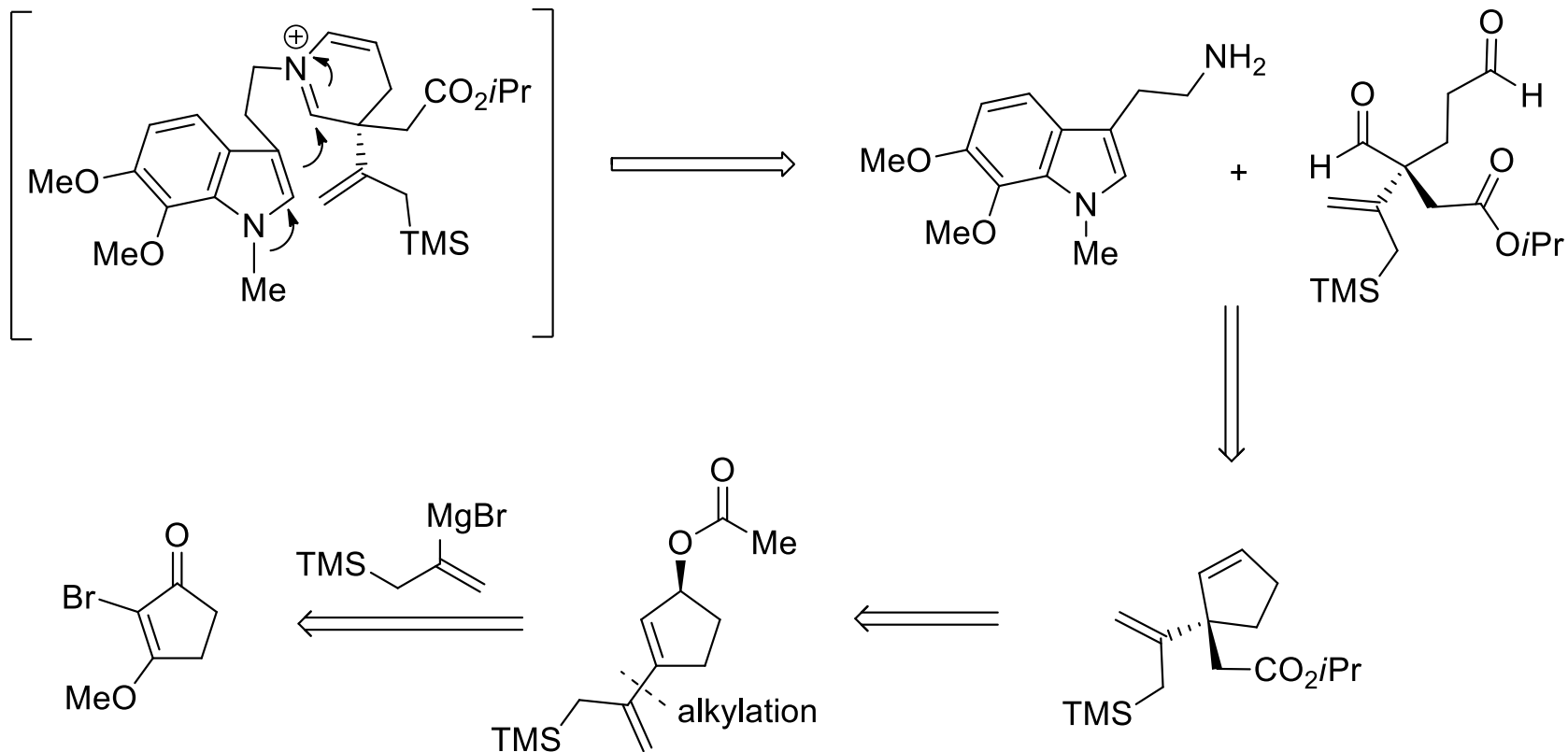

He, F., Bo, Y., Altom, J. D. Corey, E. J. *J. Am. Chem. Soc.* **1999**, *121*, 6771-6772.

Corey's total synthesis of aspidophytine

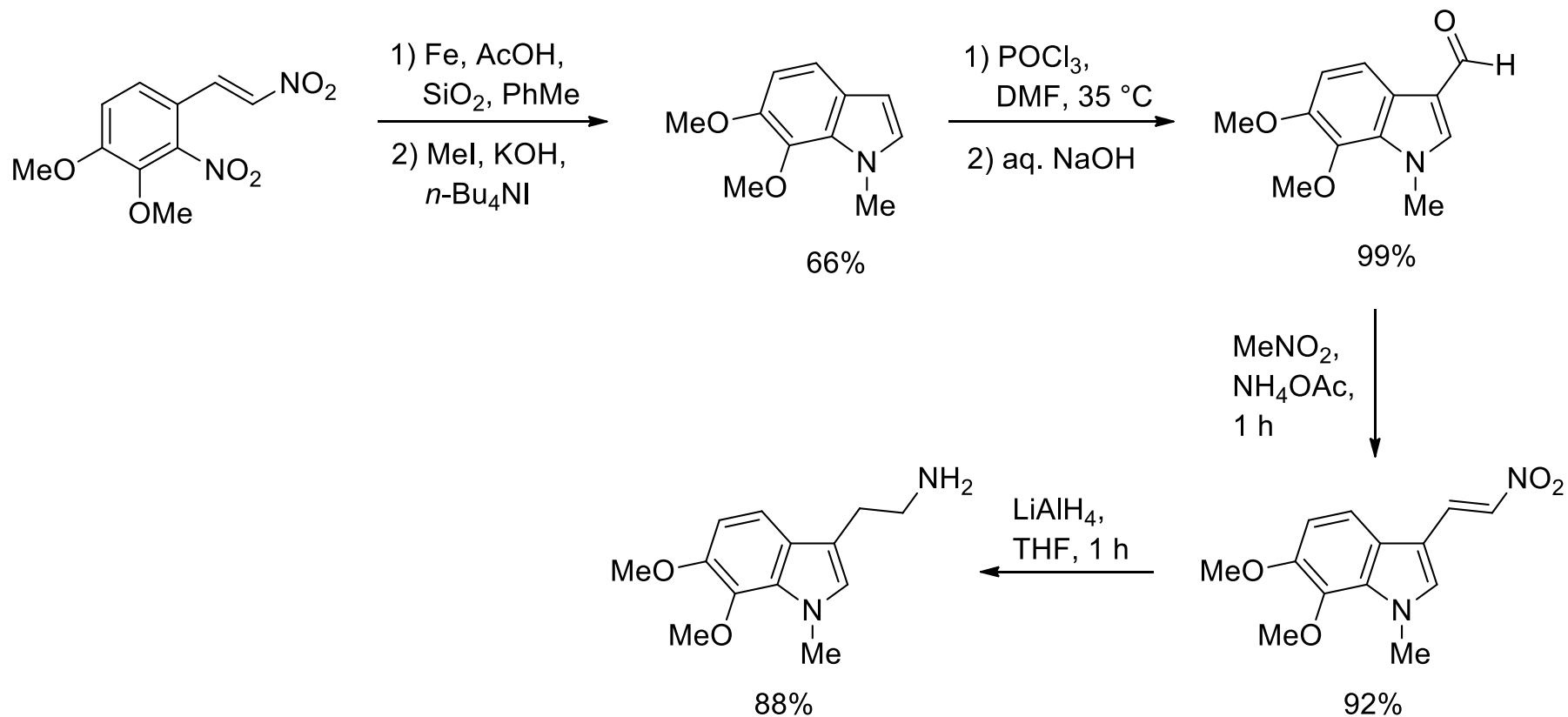

He, F., Bo, Y., Altom, J. D. Corey, E. J. *J. Am. Chem. Soc.* **1999**, 121, 6771-6772.

Corey's total synthesis of aspidophytine

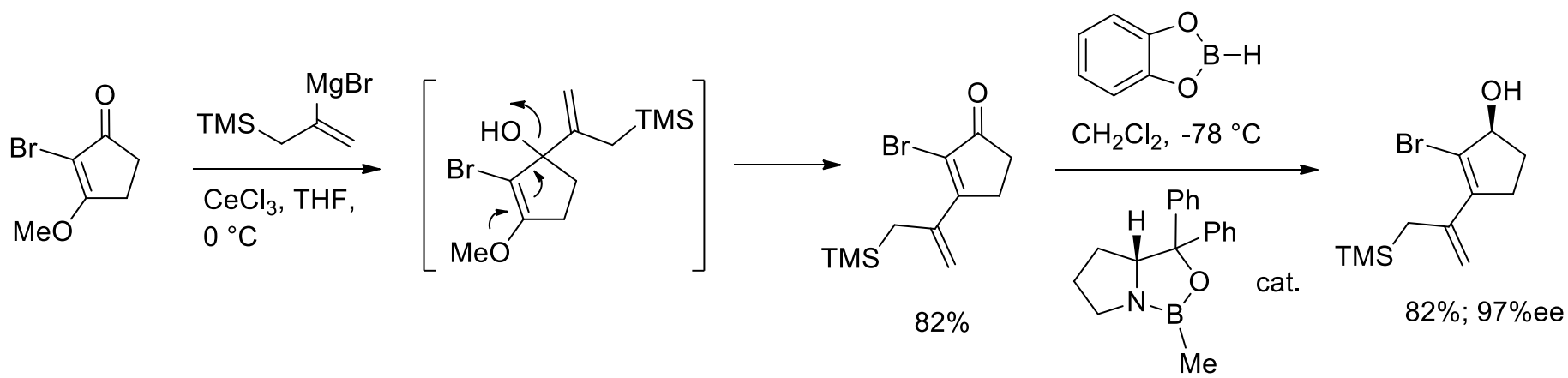

He, F., Bo, Y., Altom, J. D., Corey, E. J. *J. Am. Chem. Soc.* **1999**, *121*, 6771-6772.

Corey's total synthesis of aspidophytine

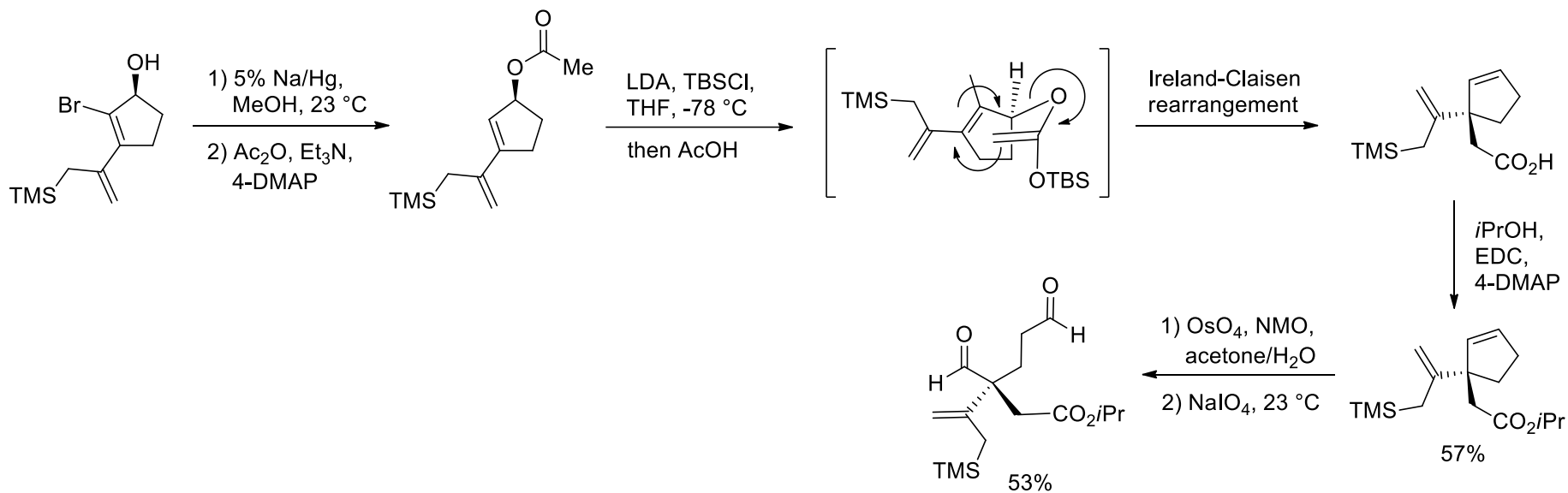

He, F., Bo, Y., Altom, J. D., Corey, E. J. *J. Am. Chem. Soc.* **1999**, 121, 6771-6772.

Corey's total synthesis of aspidophytine

The final cascade sequence

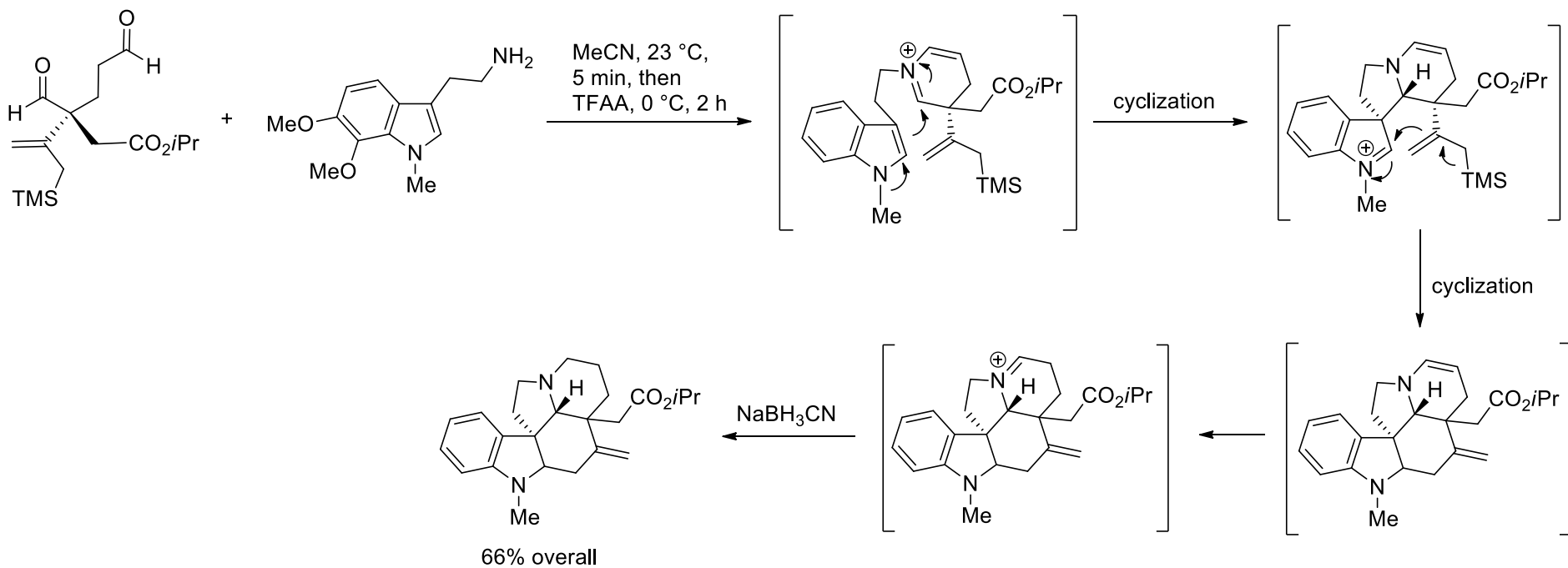

He, F., Bo, Y., Altom, J. D., Corey, E. J. *J. Am. Chem. Soc.* **1999**, 121, 6771-6772.

Corey's total synthesis of aspidophytine

Final stages and completion

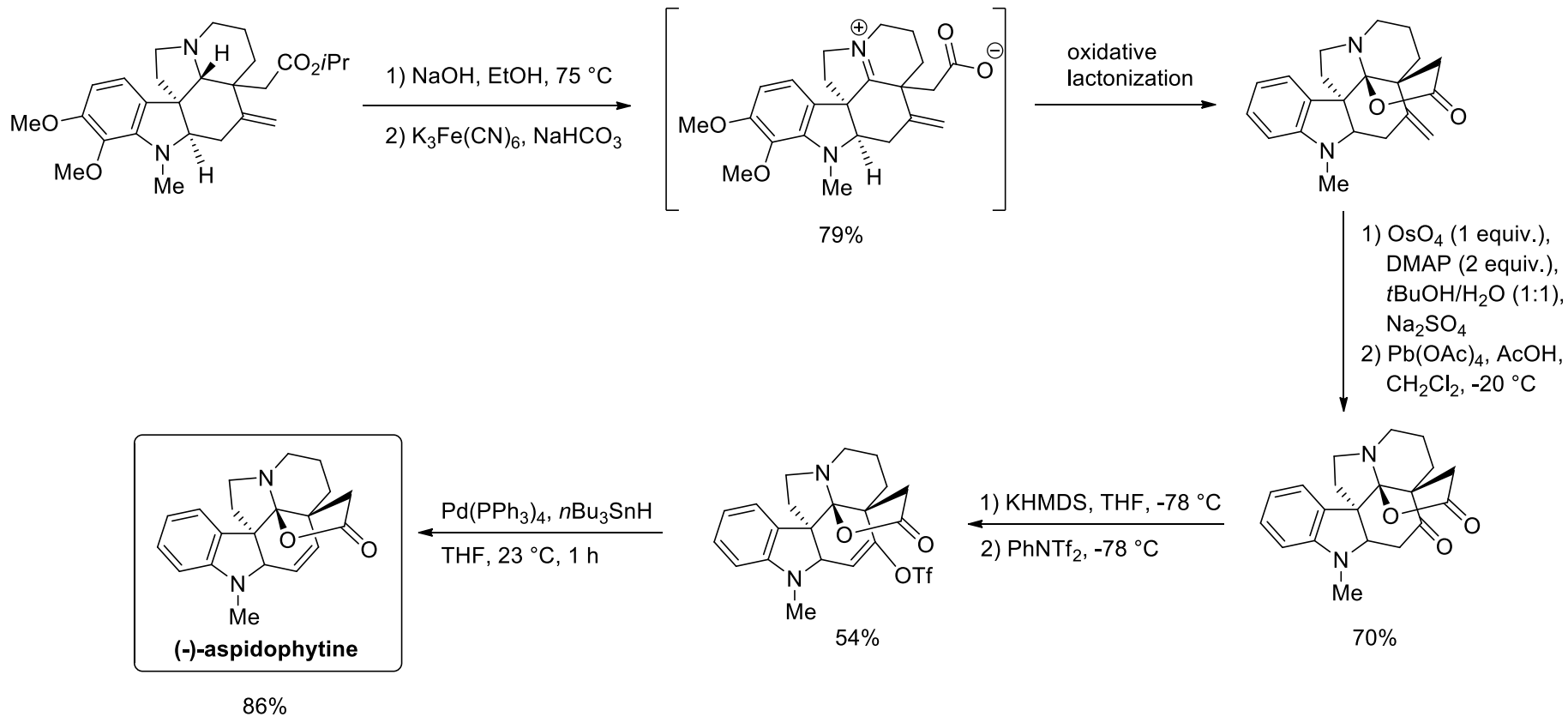

He, F., Bo, Y., Altom, J. D., Corey, E. J. *J. Am. Chem. Soc.* **1999**, *121*, 6771-6772.

A domino olefin metathesis strategy for the synthesis of (-)-halosalin

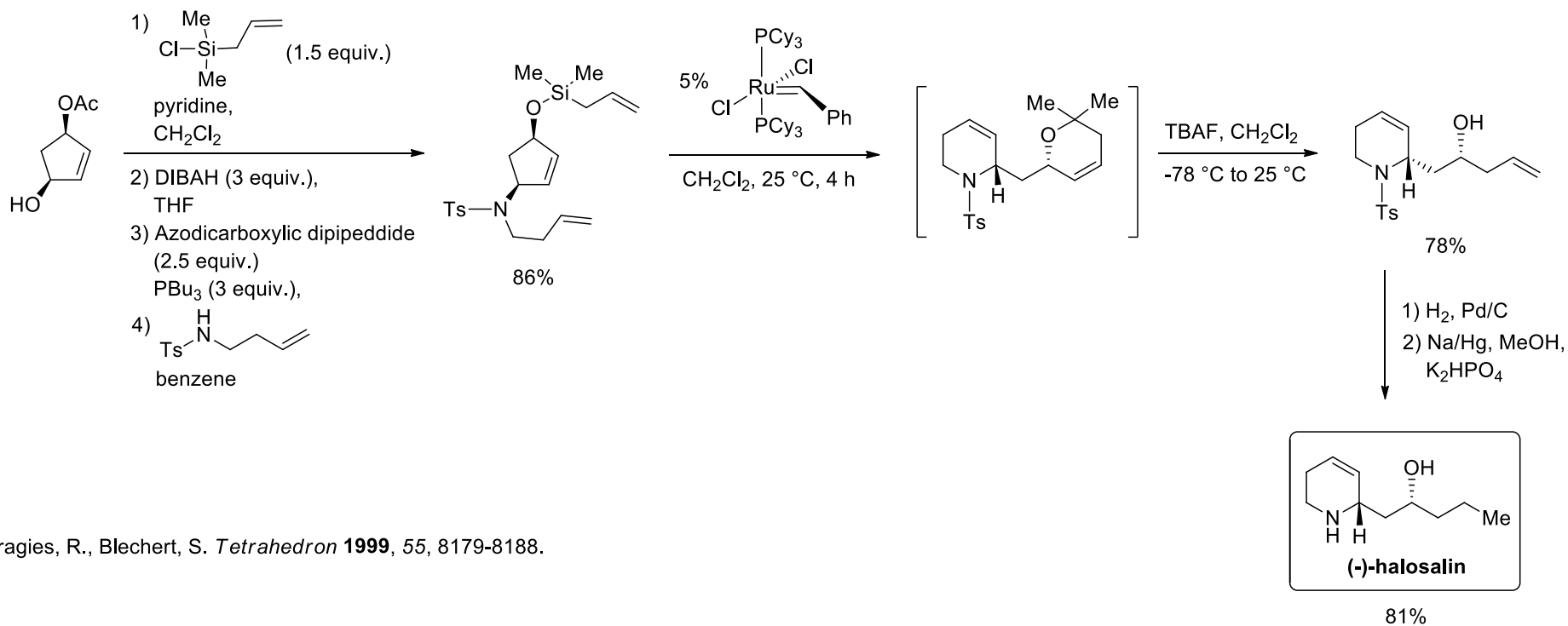

Stragies, R., Blechert, S. *Tetrahedron* **1999**, 55, 8179-8188.

Conjugated addition-alkylation route to prostaglandins

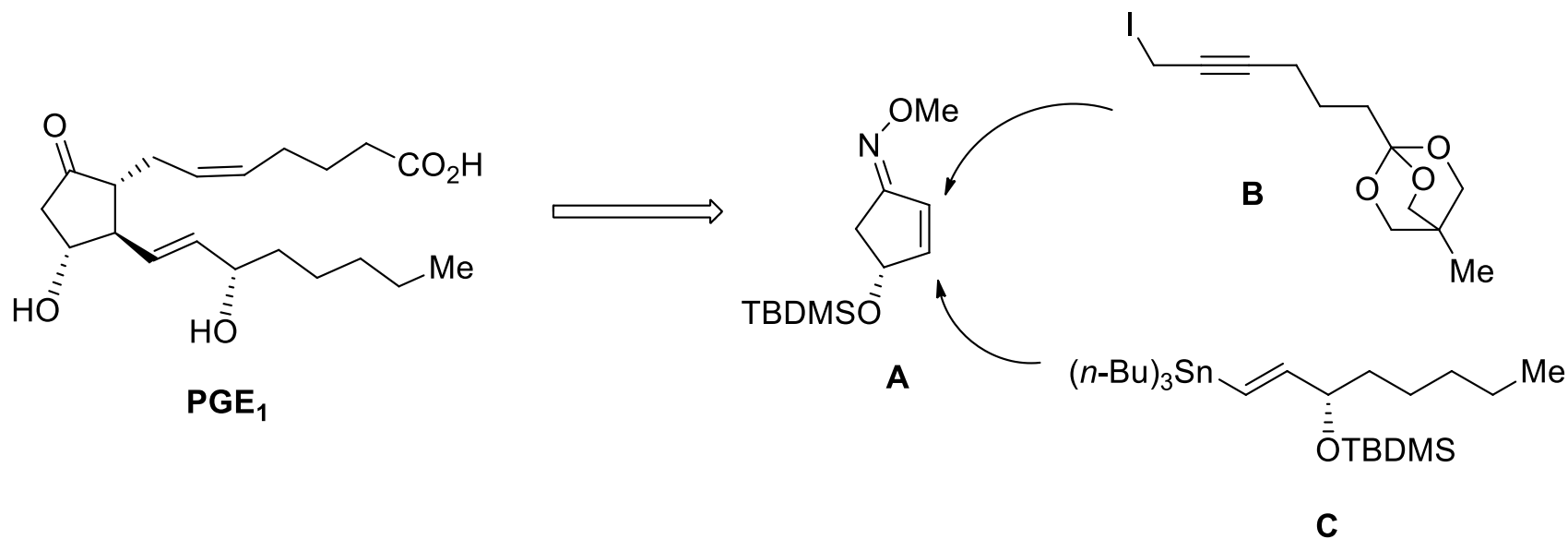

Corey, E. J., Nimura, K., Konishi, Y., Hashimoto, S., Hamada, Y. *Tetrahedron Lett.* **1986**, 27, 2199-2202;
Corey, E. J., Raju, N. *Tetrahedron Lett.* **1983**, 24, 5571-5574.

Conjugated addition-alkylation route to prostaglandins

Synthesis of fragment A

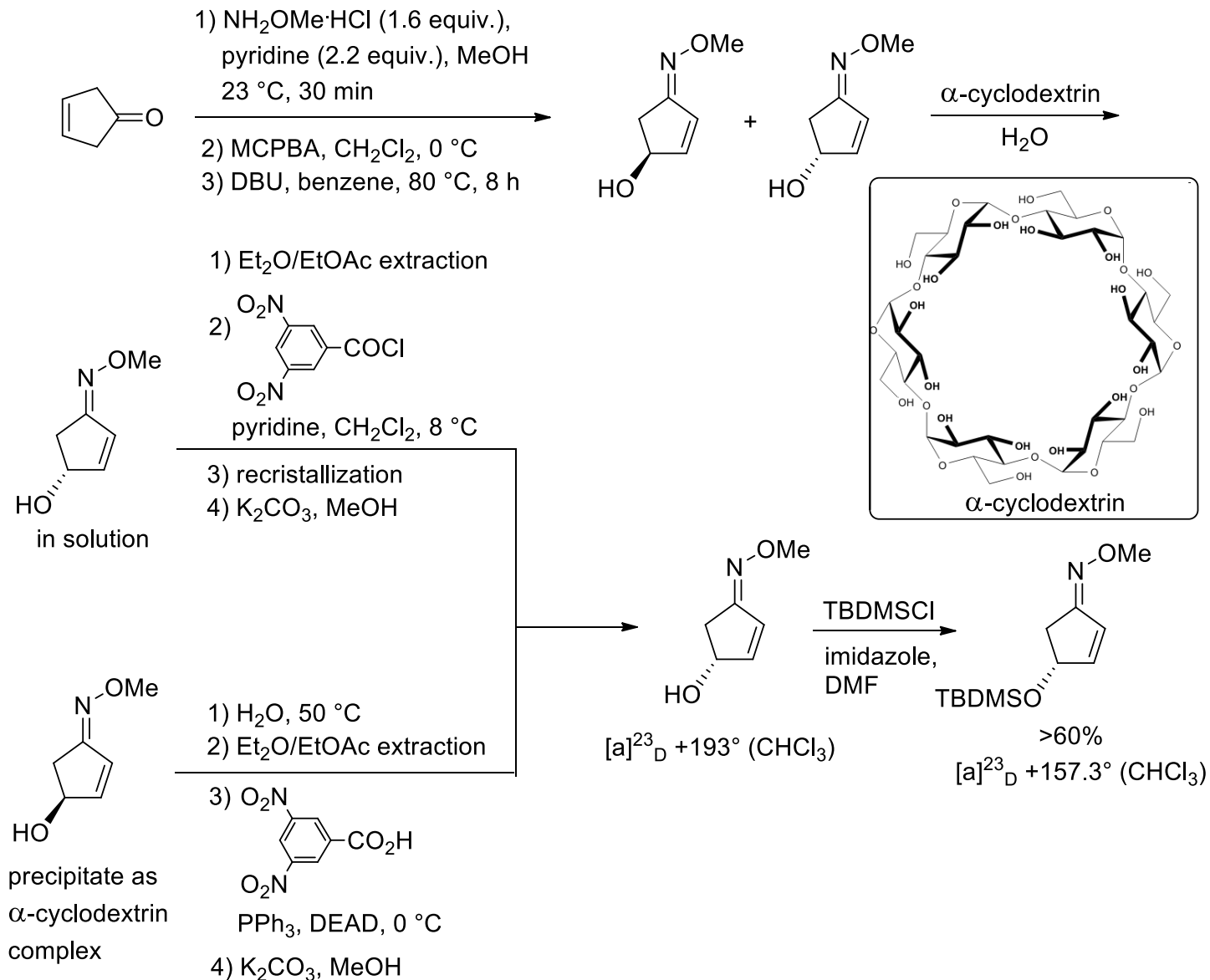

Conjugated addition-alkylation route to prostaglandins

Alternative synthesis of fragment A starting from diethyl (S,S)-tartrate

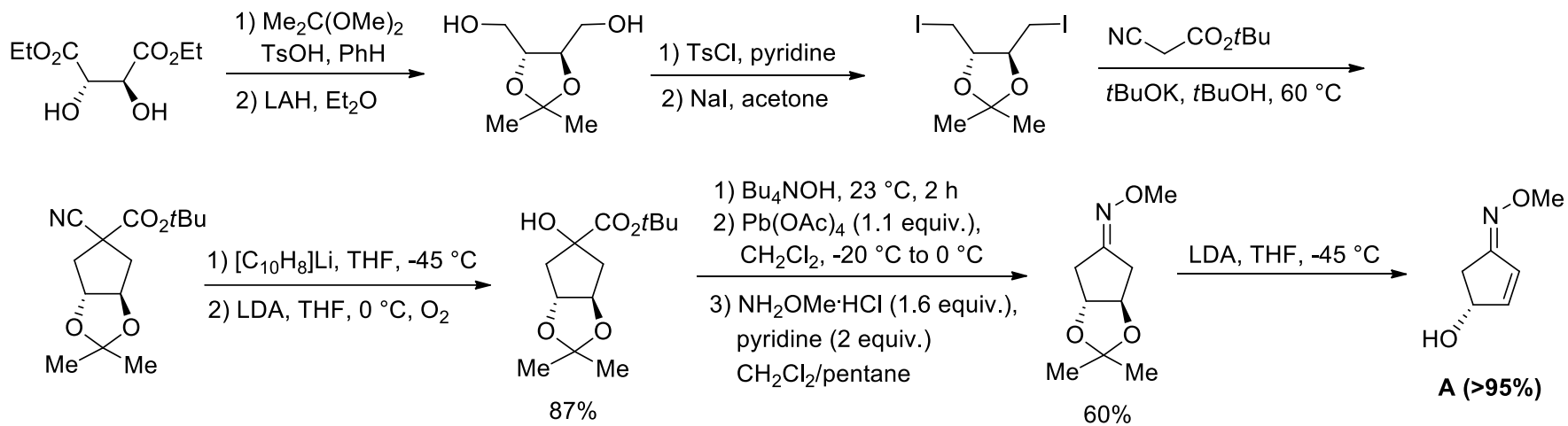

Corey, E. J., Nimura, K., Konishi, Y., Hashimoto, S., Hamada, Y. *Tetrahedron Lett.* **1986**, 27, 2199-2202.

Conjugated addition-alkylation route to prostaglandins

Synthesis of fragment B

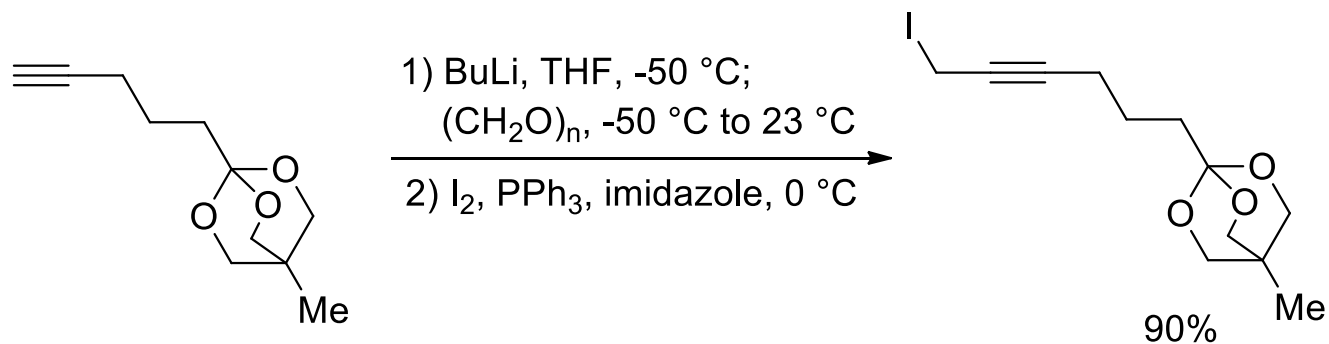

Corey, E. J., Raju, N. *Tetrahedron Lett.* **1983**, 24, 5571-5574.

Conjugated addition-alkylation route to prostaglandins

Synthesis of fragment C

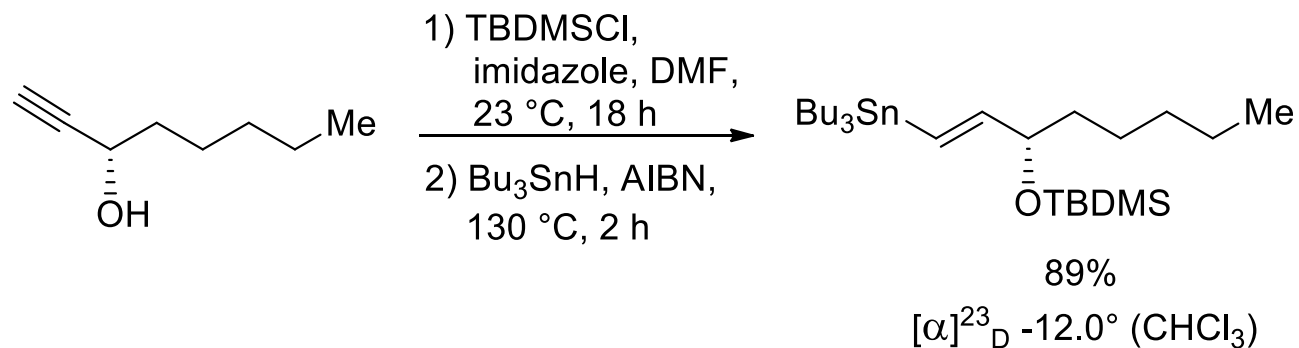

Corey, E. J., Raju, N. *Tetrahedron Lett.* **1983**, 24, 5571-5574.

Additional asymmetric syntheses

Enantioselective alkylation by chiral phase-transfer catalysis

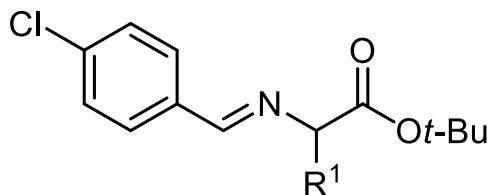
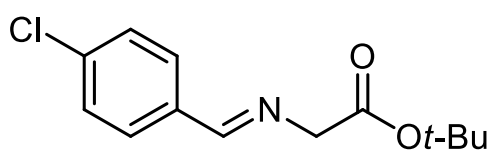
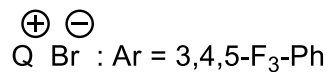
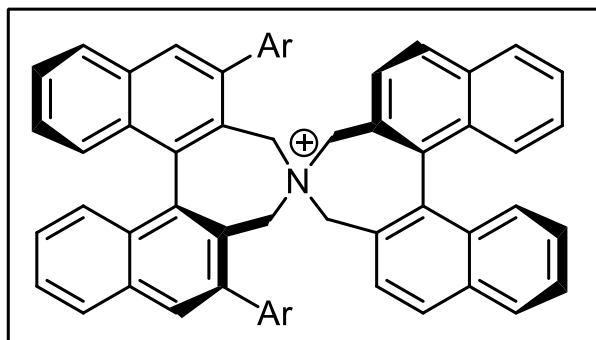

1) R¹-X

2) R²-X
CsOH, toluene
-10 °C → 0 °C

QX (1 mol%)

R²-X, CsOH, H₂O
toluene, -20 °C → 0 °C

H⁺

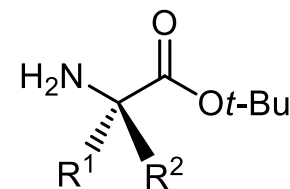

51-85%
91-99% ee

K. Maruoka, *Synlett* **2001**, 1185.

Enantioselective fluorination reactions

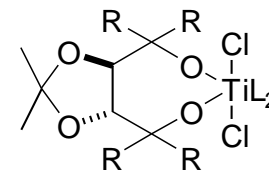
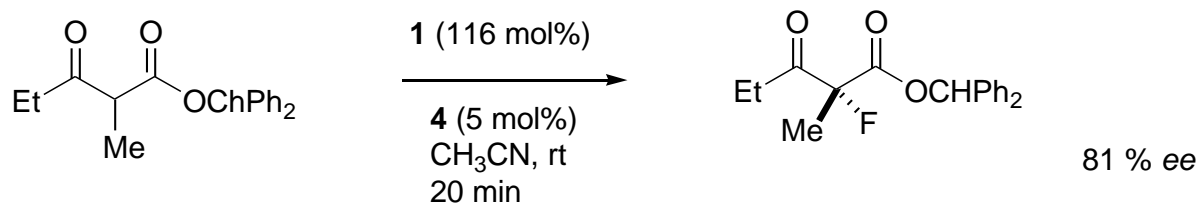
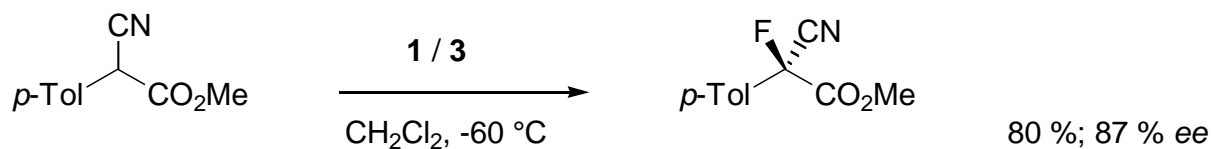
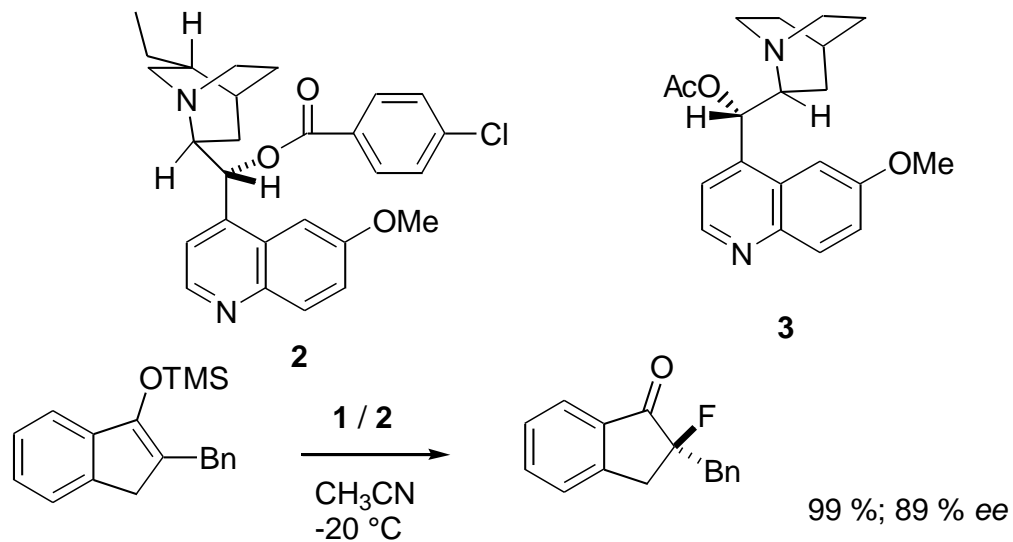
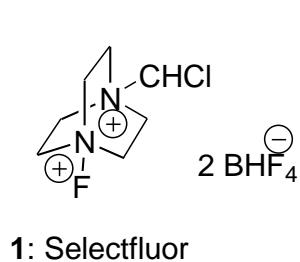

4: R = 1-Naph
L₂ = (CH₃CN)₂

Munoz, K. *Angew. Chem. Int. Ed.* **2001**, *40*, 1653

Asymmetric reduction of C=C-bonds

Synthesis of amino-alcohol derivatives

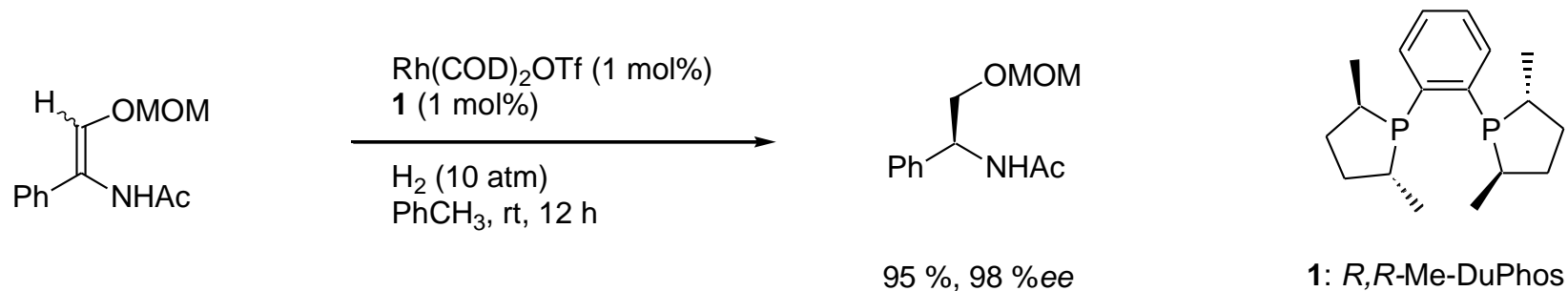

Zhang, X. *J. Org. Chem.* **1998**, 63, 8100.

Chiral monophosphines for the enantioselective hydrogenation of functionalized olefins

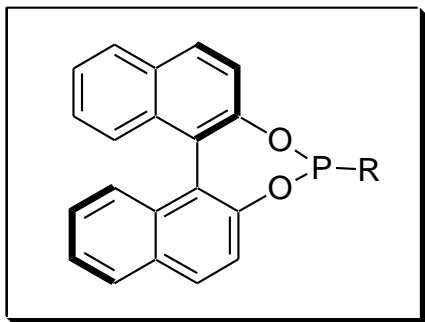

R = *t*-Bu, Et, NMe₂, (R)-O-CH(Me)Ph

High enantioselectivities are reached with BINAP-derived phosphines and phosphoramidates for asymmetric hydrogenations.

Review: Börner, A. *Angew. Chem. Int. Ed.* **2001**, *40*, 1197

Asymmetric reduction of C=O bonds

Rapid, catalytic and stereoselective hydrogenation of ketones
Noyori, R. *Pure Appl. Chem.* **1999**, 71, 1493.

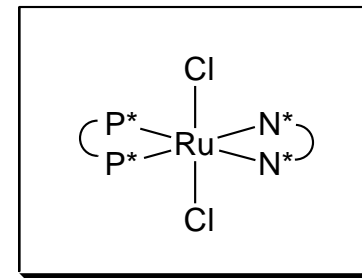
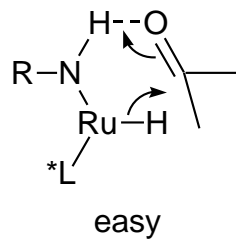
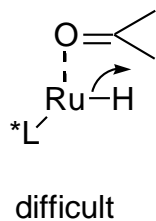

chiral Ru-complex

Noyori-catalyst system

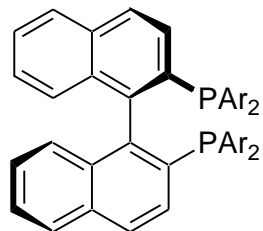

Ar = C₆H₅: (R)-BINAP
Ar = 4-Me-C₆H₄: (R)-ToIBINAP
Ar = 3,5-Me₂C₆H₃: (R)-XylBINAP

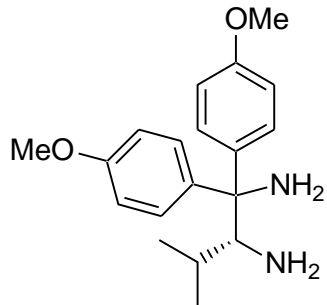

(R)-DAIPEN

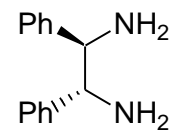

(R,R)-DPEN

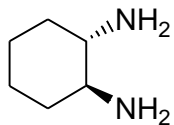

(R,R)-cyclohexanediamine

Asymmetric reduction of ketones

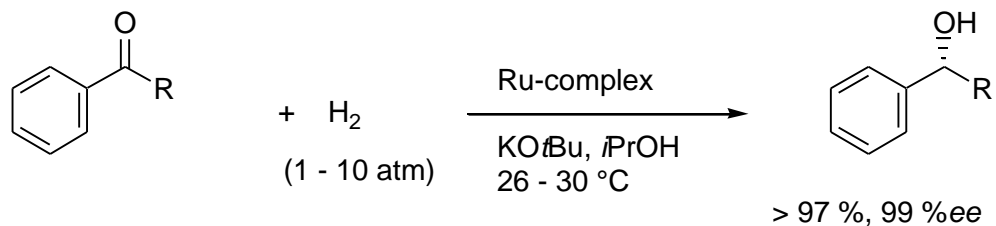

Ru : ketone = 1 : 500 to 1 : 5000

R = Me, Et, *i*Pr
R = cyclopropyl: 96 %ee

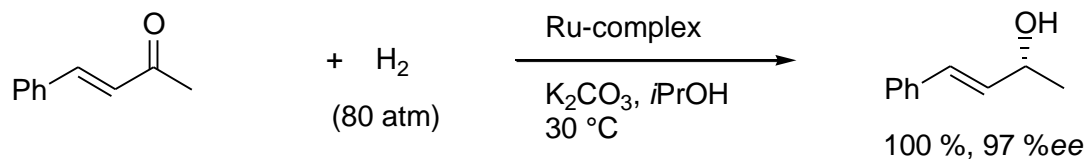

ketone : Ru : K₂CO₃ = 100 000 : 1 : 10 000
Ru-complex: RuCl₂-(*S*)-XylBINAP-(*S*)-DAIPEN

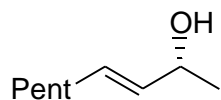

97 %ee

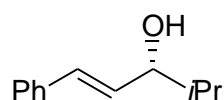

86 %ee

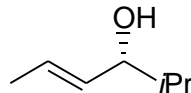

90 %ee

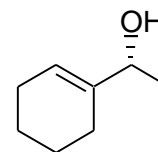

100 %ee

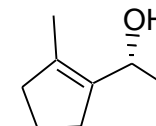

99 %ee

Asymmetric transfer hydrogenation

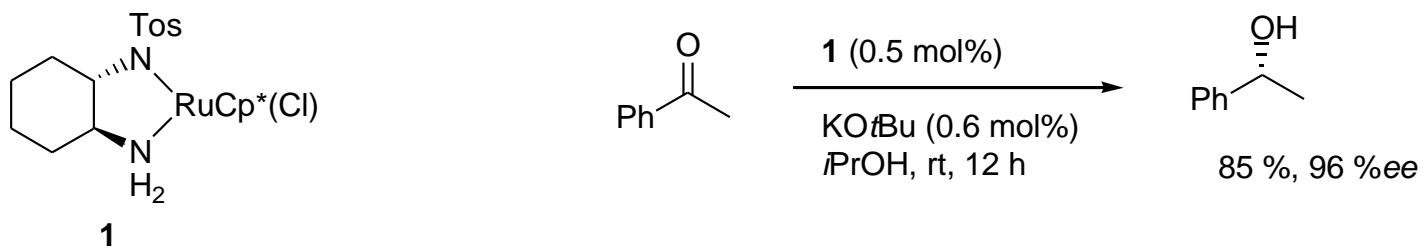

Noyori, R. *J. Org. Chem.* **1999**, *64*, 2186.

Asymmetric reduction of C=N-bonds

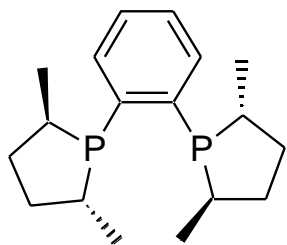

1: *R,R*-Me-DuPhos

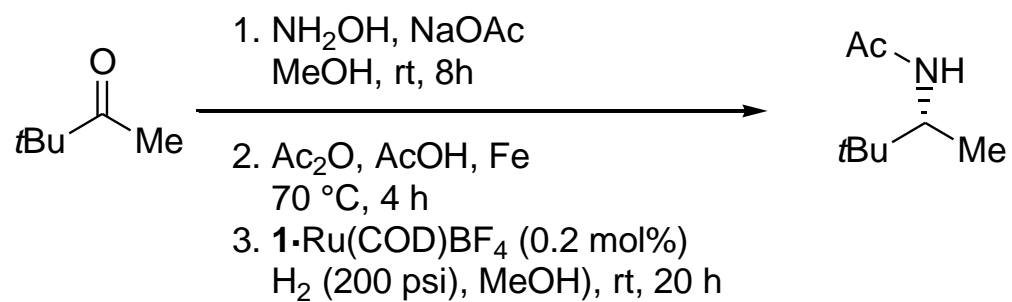

Burk, M.J. *J. Org. Chem.* **1998**, 63, 6084.

Catalytic asymmetric reductive amination

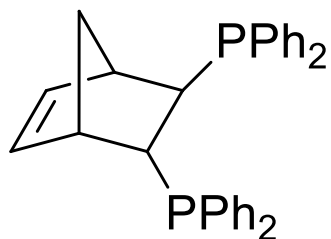
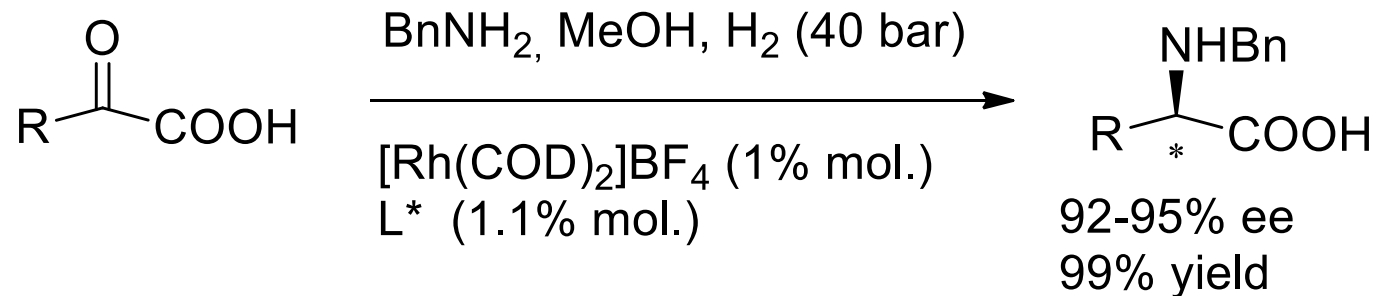

(R,R) -Norphos

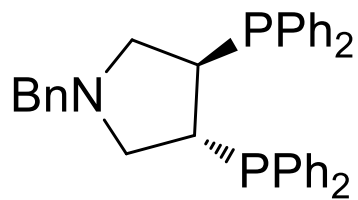

(R,R) -Deguphos

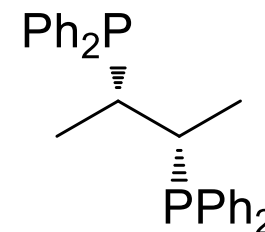

(S,S) -Chiraphos

R. Kadyrov, *J. Org. Chem.*, **2003**, 68, 4067

Asymmetric C-C-bond formation

1,4-Addition using Zn-reagents

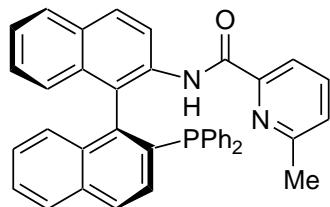
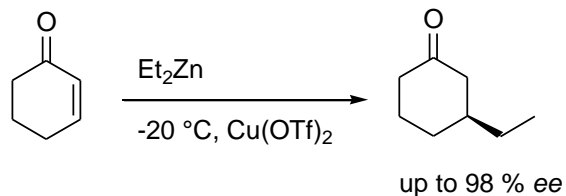

Zhang (3 mol %)

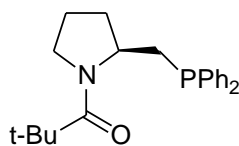

Tomioka (4.5 equiv.)

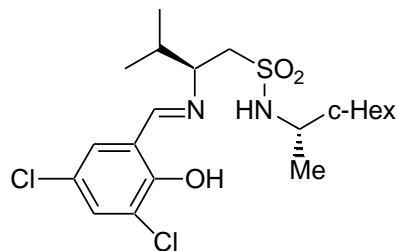

Gennari (3 mol %)

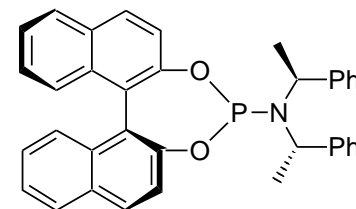

Feringa

Zhang, X. *Angew. Chem.* **1999**, *111*, 3720.

Tomioka, K. *Tetrahedron* **1999**, *55*, 3831.

Gennari, C. *Angew. Chem. Int. Ed. Engl.* **2000**, *39*, 916.

Feringa, B.L. *Angew. Chem. Int. Ed. Engl.* **1997**, *36*, 916.

Review: Feringa, B. L. *Acc. Chem. Res.* **2000**, *33*, 346 and Krause, N. *Synthesis*, **2001**, 171

Catalytic enantioselective synthesis of prostaglandin E₁ methyl ester

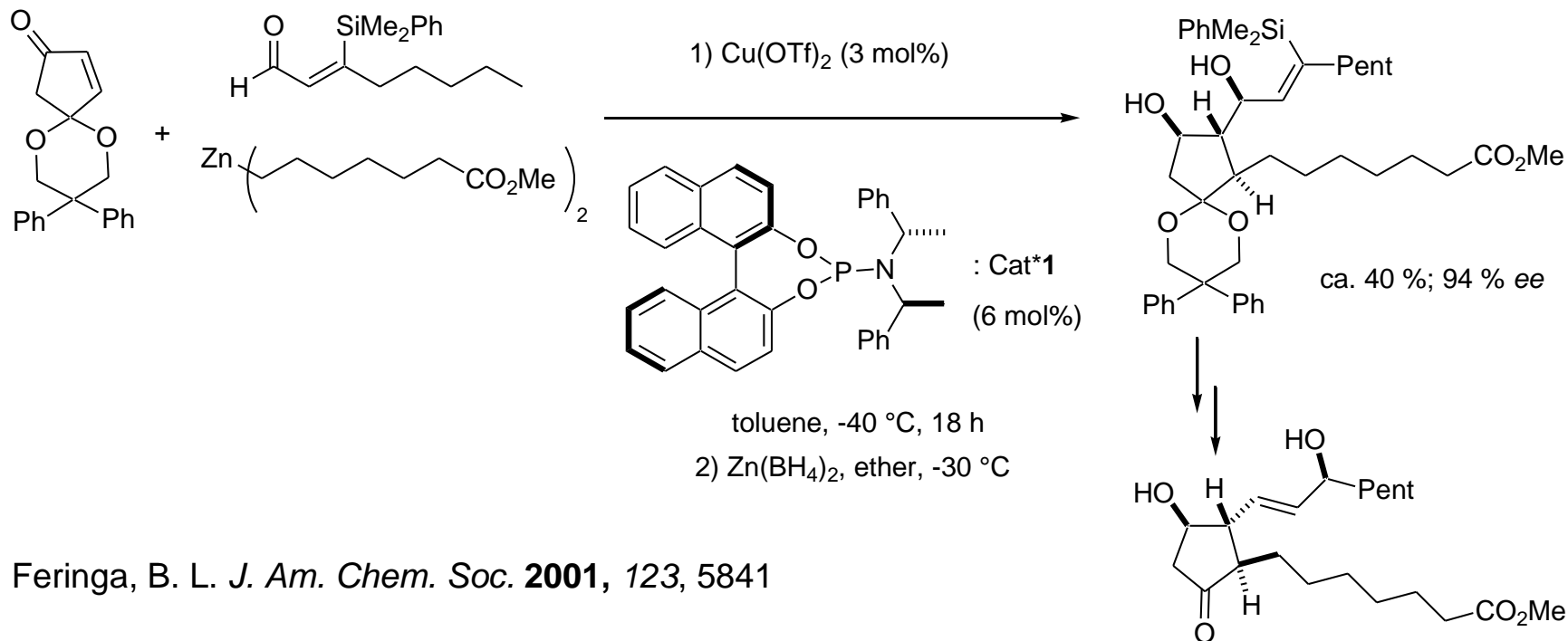

Feringa, B. L. *J. Am. Chem. Soc.* **2001**, 123, 5841

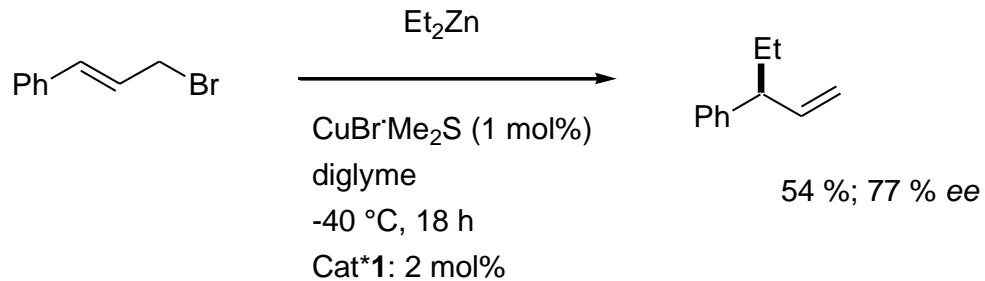

Feringa, B. L. *Org. Lett.* **2001**, 3, 1169

Asymmetric conjugated additions

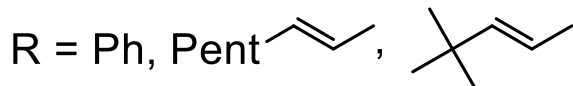
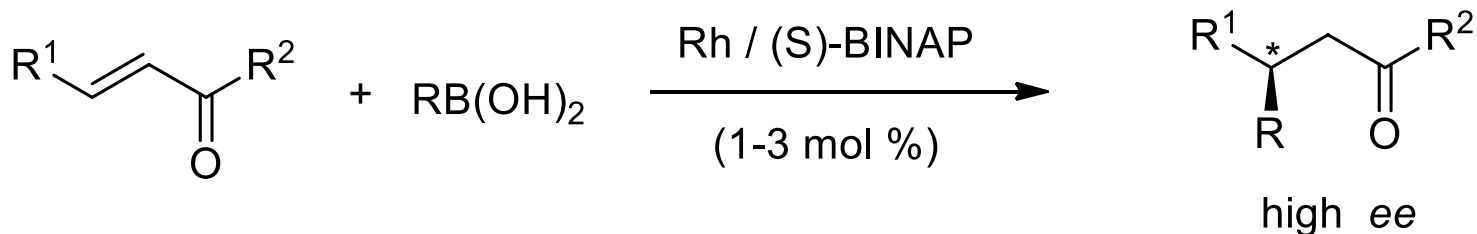
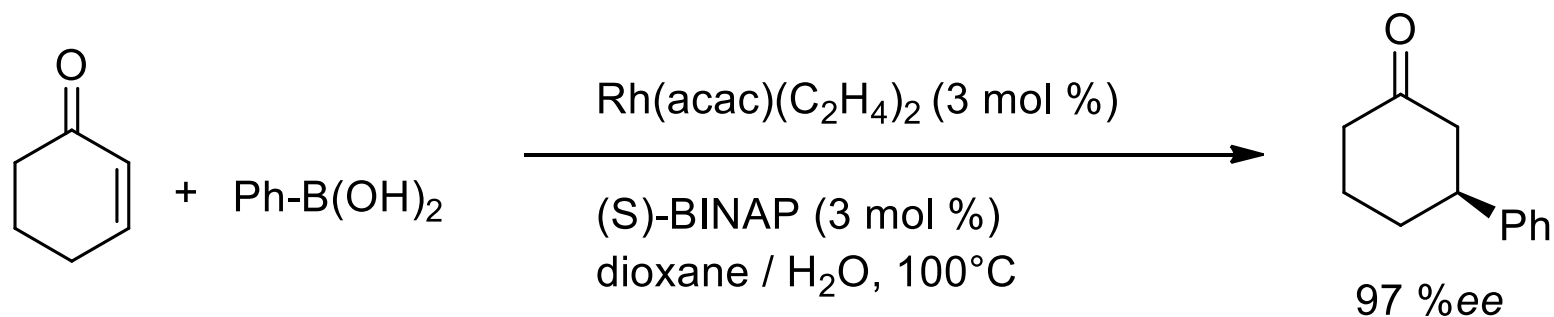

T. Hayashi *J. Am. Chem. Soc.* **1998**, *120*, 5597; **2002**, *124*, 5052;
M. T. Reetz, *Org. Lett.* **2002**, *3*, 4083

Hayashi-Michael-addition

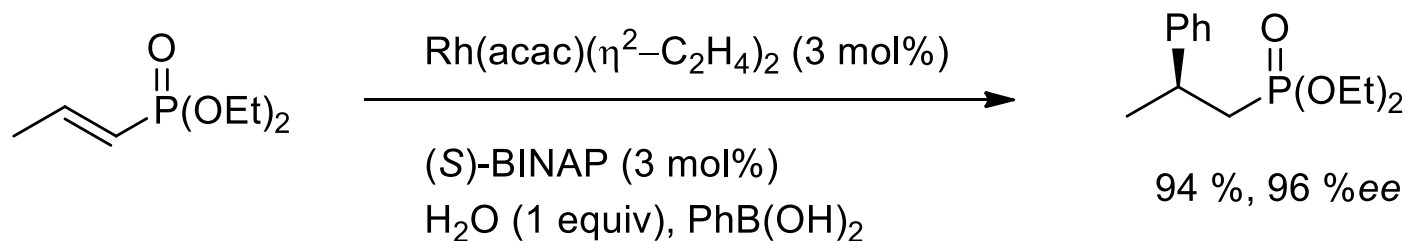

T. Hayashi, *J. Am. Chem. Soc.* **1999**, *121*, 11591.

For a review on the Hayashi reaction :T. Hayashi, *Synlett*, **2001**, 879

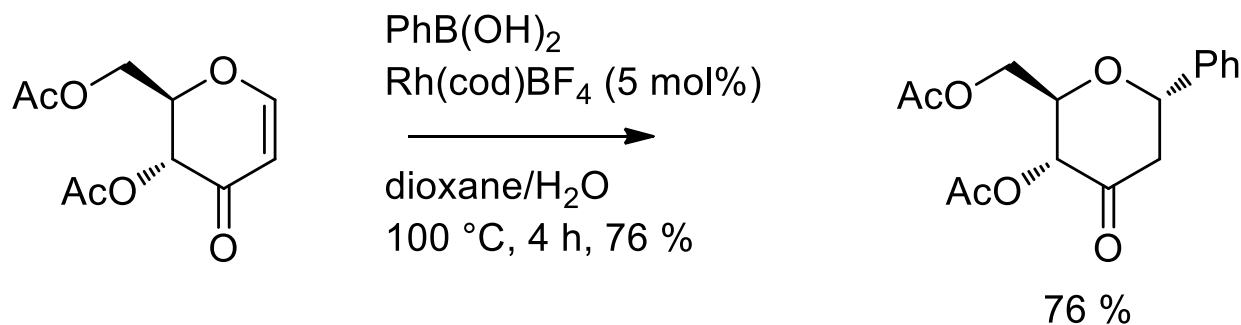

S. P. Maddaford, *Org. Lett.* **2001**, *3*, 2571

Rh-catalyzed asymmetric conjugate addition of organoboronic acids to nitroalkenes

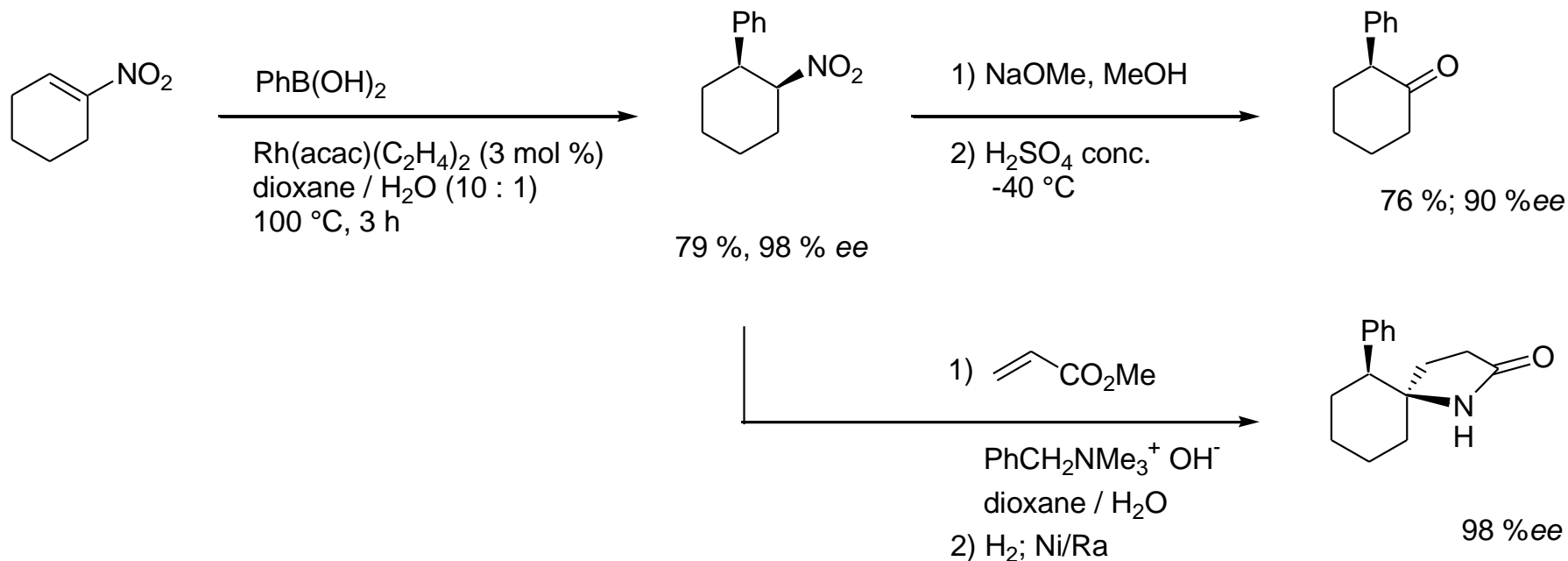

Hayashi, T. *J. Am. Chem. Soc.*, **2000**, 122, 10716

Zinc(II) mediated enantioselective synthesis of propargylic alcohols

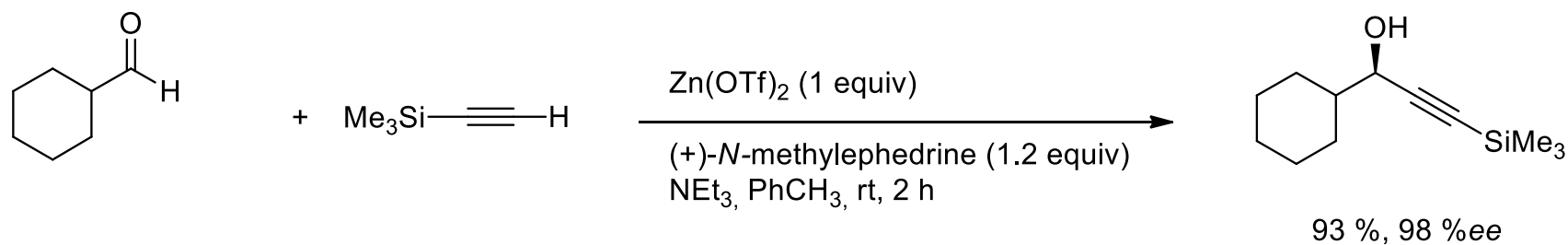

E. M. Carreira, *J. Am. Chem. Soc.* **2000**, *122*, 1806.

E. M. Carreira, *Org. Lett.* **2000**, *2*, 4233; **2001**, *3*, 3017

see also *Org. Lett.* **2002**, *4*, 1855

Lanthanide trifluoromethanesulfonate - catalyzed asymmetric aldol reaction in water

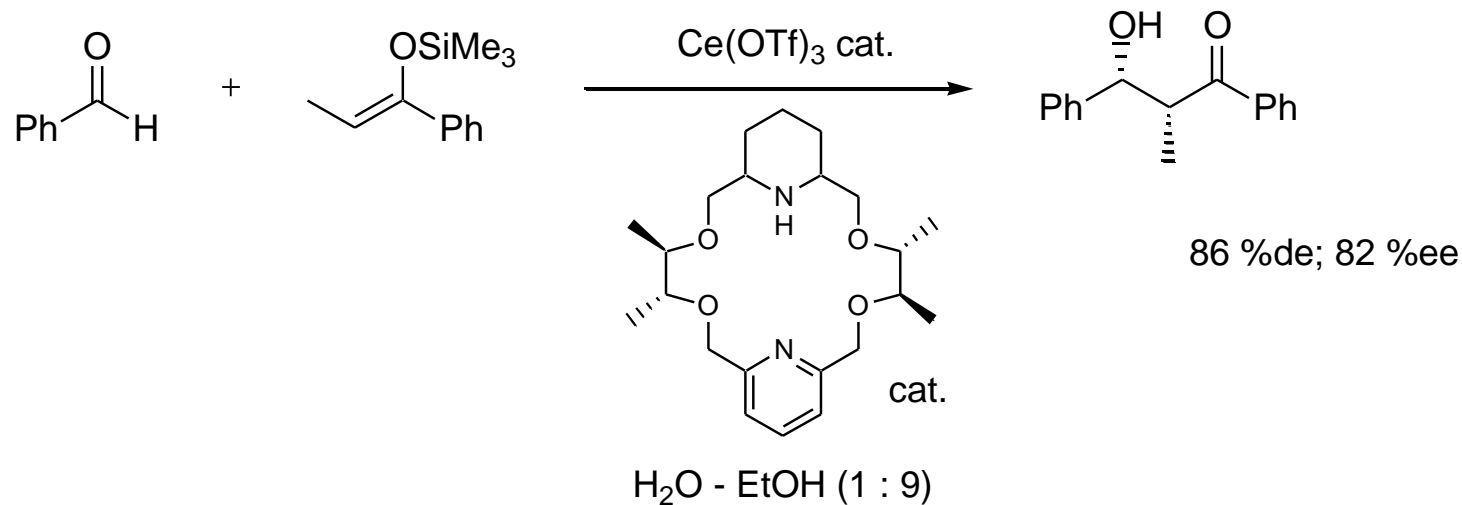

Kobayashi, S. *Org. Lett.* **2001**, 3, 165

Asymmetric aldol reaction via a dinuclear zinc catalyst

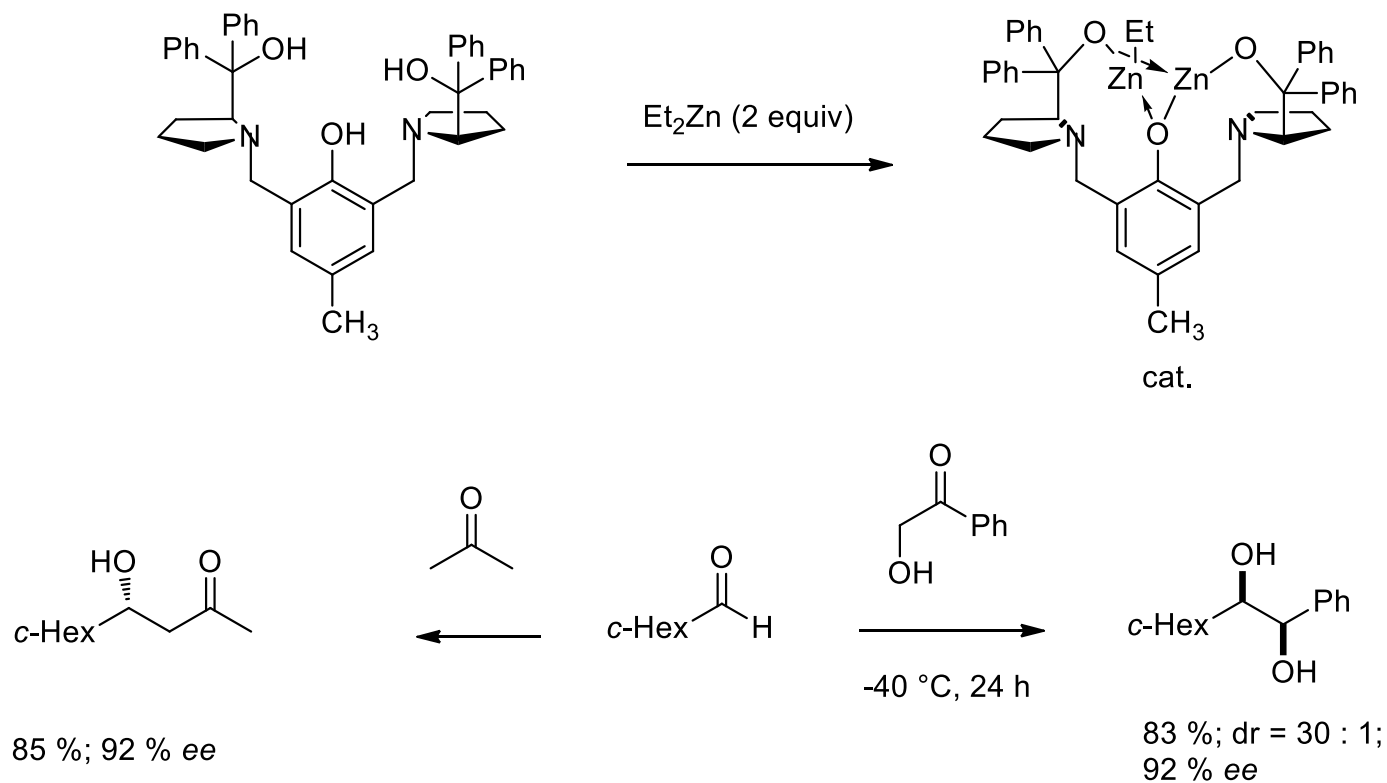

B. M. Trost, *J. Am. Chem. Soc.* **2001**, 123, 3367; *Org. Lett.* **2001**, 3, 2497

Catalytic synthesis of 1,2-diols mediated by (L)-proline

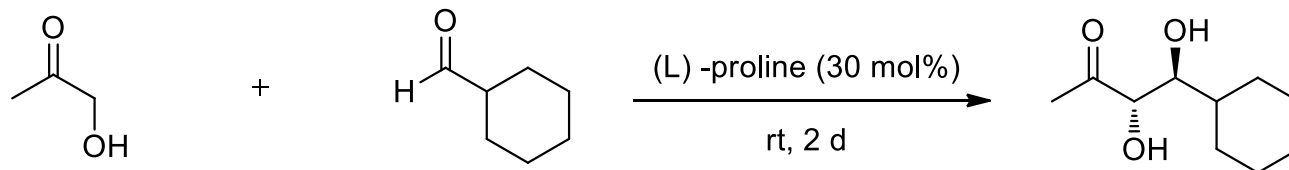

60 %; diastereoselect. > 20 : 1
enantioselect. > 100 : 1

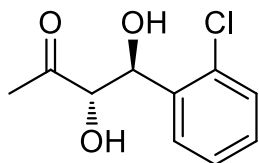

67 %ee
d.r. = 1.5 : 1

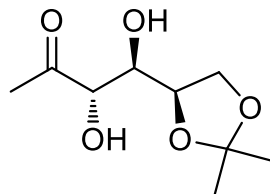

97 %ee
d.r. = 2 : 1

B. List, *J. Am. Chem. Soc.* **2000**, 122, 7386; *Org. Lett.* **2001**, 3, 573
For a review, see: B. List, *Synlett* **2001**, 1663

Enantioselective cross-aldol reaction of aldehydes

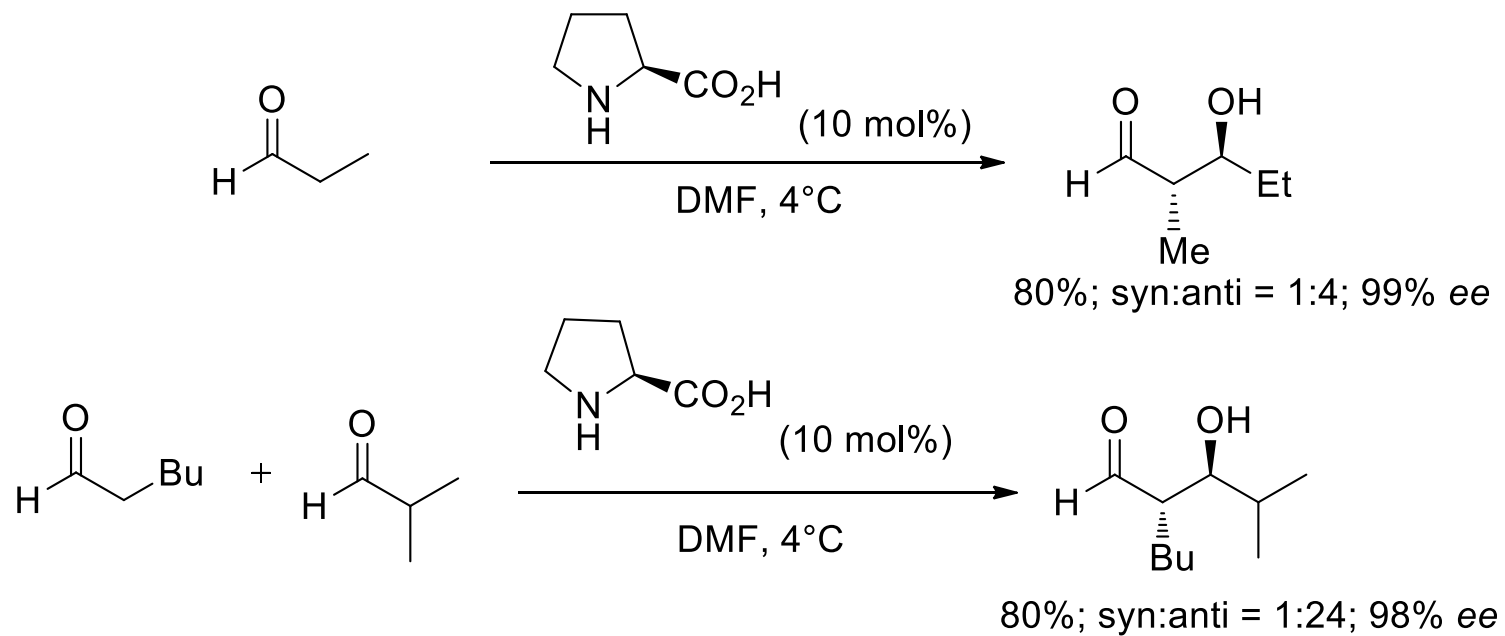

D. W. C. MacMillan, *J. Am. Chem. Soc.* **2002**, 124, 6798

Catalytic asymmetric Mannich reaction mediated by (L)-proline

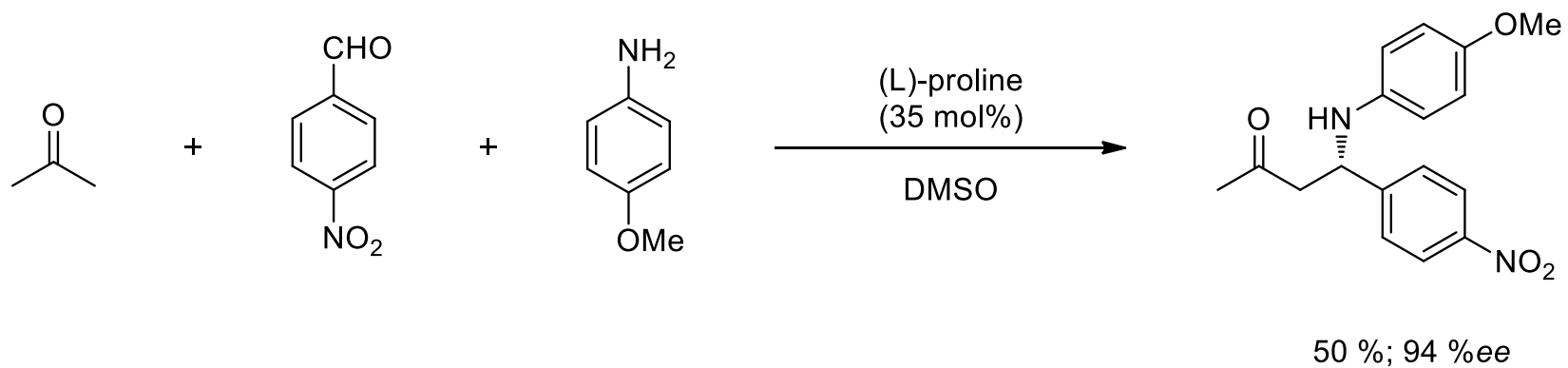

B. List *J. Am. Chem. Soc.* **2000**, *122*, 9336; **2002**, *124*, 827

Organocatalytic Diels - Alder reaction

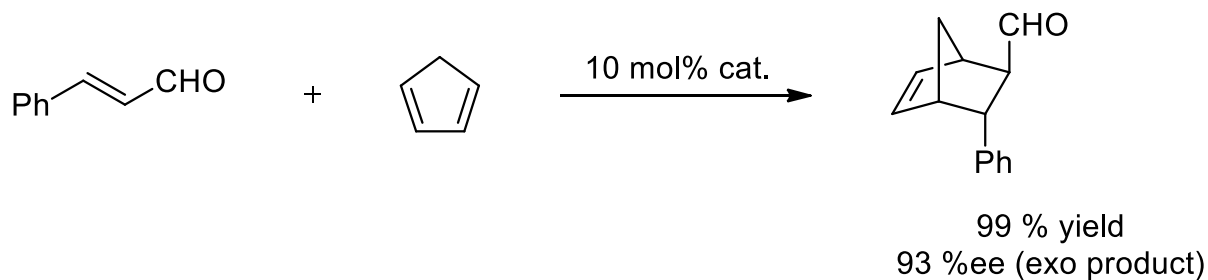
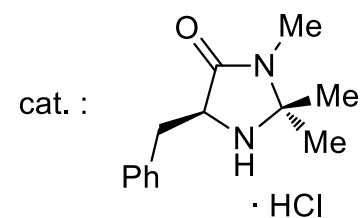
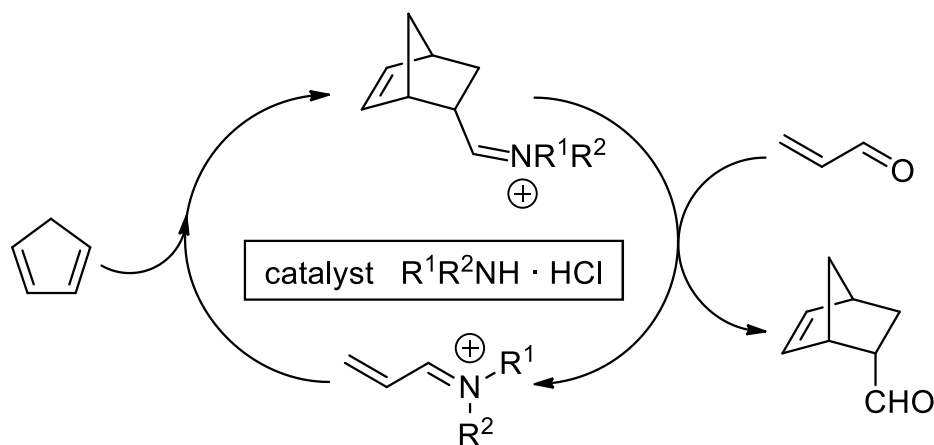

D.W.C. McMillan, *J. Am. Chem. Soc.* **2000**, 122, 4243.

For a review on organocatalysis : D. I. Dalgo, *Angew. Chem. Int. Ed.* **2001**, 40, 3726

Organocatalytic alkylation of methyl 4-oxobutenoate

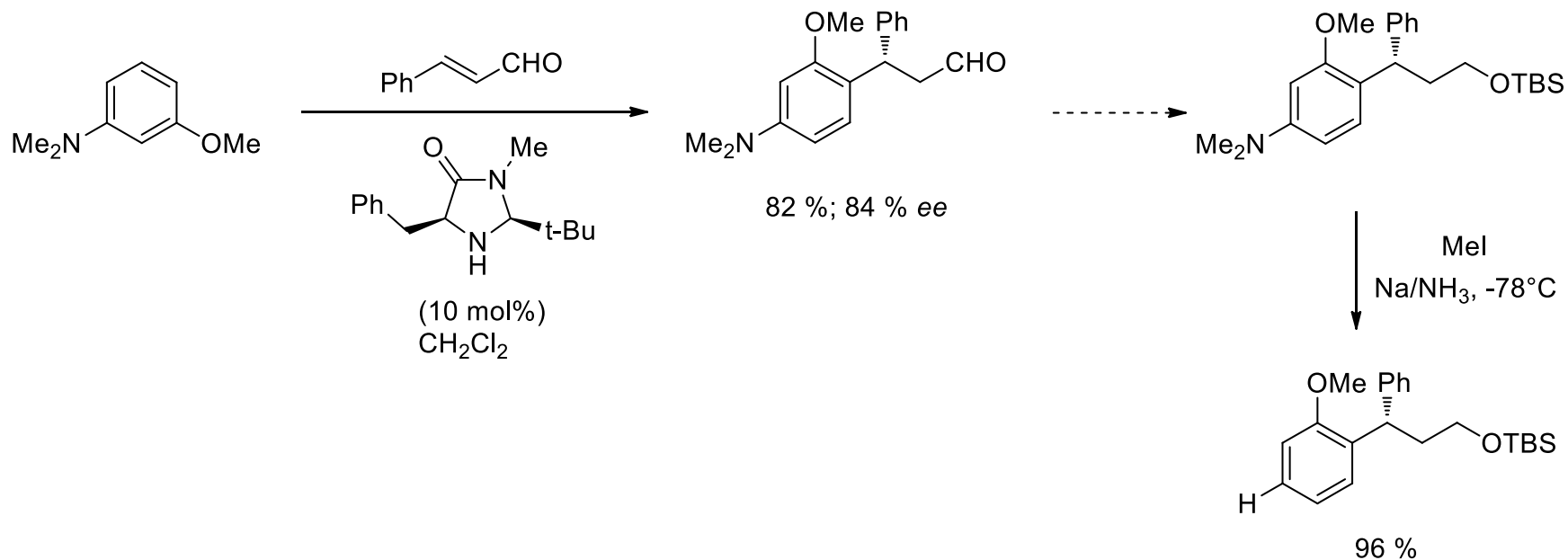
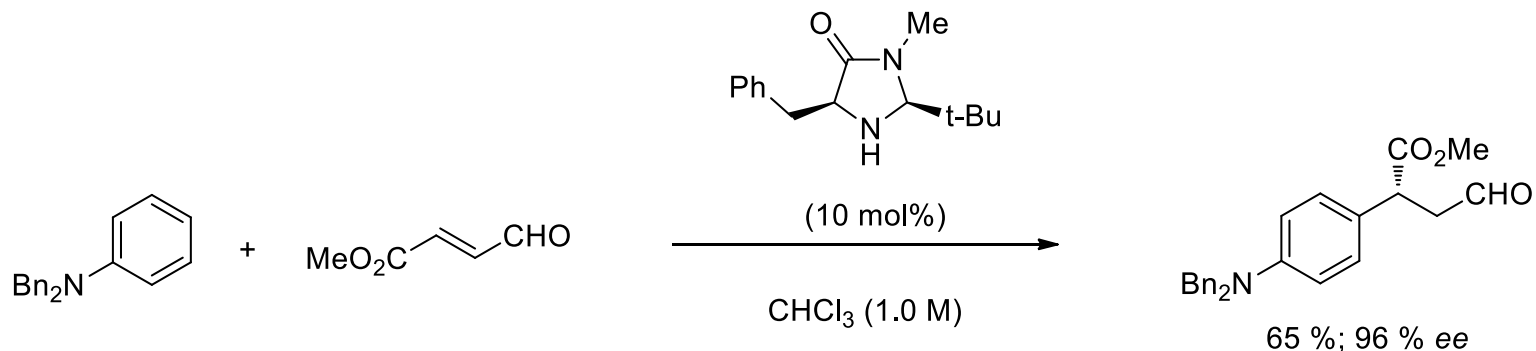

D. W. C. McMillan, *J. Am. Chem. Soc.* **2002**, 124, 7894